

Power, control and signaling interface

Power, control and signaling products are the complementary devices of the distribution board. Their functions are used to improve comfort and savings. They also allow to control and isolate circuits in housing and commercial installations.



AC-3 contactors	5.2
Modular contactors	5.12
Delay timers	5.21
Interface relays	5.22
Latching relays	5.23
Switch disconnectors	5.25
Changeover switches	5.27
Trip-free switches	5.29
Indicator lights	5.31
Push buttons	5.32
Emergency lighting	5.34
Transformers, bells and buzzers	5.35
Technical guide	5.37

References*	EW005	EW006
		

Main contact				
Rated insulation voltage U_i (V)		690		
Rated operational voltage U_e (V)		690		
Thermal current I_{th} (A)		20		
Main contact rated operational current AC-3 le	Single pole	110V	8A / 0.37 kW	10.5A / 0.55kW
		220V	7A / 0.75kW	10A / 1.1kW
	Three pole	220/230V	7.5A / 1.5kW	10.1A / 2.2kW
		380/400V	7A / 3kW	9A / 4kW
		415V	6.5A / 3kW	8.5A / 4kW
		440V	6A / 3kW	8A / 4kW
		500V	5A / 3kW	6.5A / 4kW
		660V	4A / 3kW	5A / 4kW
		690V	4A / 3kW	5A / 4kW

Auxiliary contact				
Rated insulation voltage U_i (V)		690		
Rated operational voltage U_e (V)		380		
Thermal current I_{th} AC/DC (A)		10/2.5		
Auxiliary contact rated operational current le	AC-15	120V	6	6
		240V	3	3
		380V	1.9	1.9

Contactor life		
Operation frequency (cycles/hour)		1200
Electrical lifespan (operations)		1,000,000
Mechanical lifespan (operations)		5,000,000

Others			
Type of auxiliary contact	NO	1	1
	NC	0	0
Weight (kg)		0.18	0.18

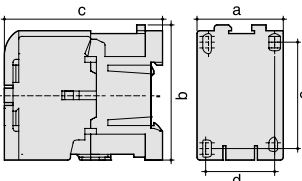
Dimensions (mm)			
	a	45	45
	b	54	54
	c	58	58
	d	35	35
	e	50	50

* **Note:** Control circuit rated operational voltage

C: 220V AC 50/60Hz (EW005_C ~ EW006_C)	H: 110V AC 50/60Hz (EW005_H ~ EW006_H)
D: 380V AC 50/60Hz (EW005_D ~ EW006_D)	N: 24V AC 50/60Hz (EW005_N ~ EW006_N)
E: 24V DC 50/60Hz (EW005_E ~ EW006_E)	P: 48V AC 50/60Hz (EW005_P ~ EW006_P)
F: 48V DC 50/60Hz (EW005_F ~ EW006_F)	

Thermal overload relays

- h.62 x l.45 x w.60 mm

Setting range	Cat. ref.
0.1 - 0.16A	EWT001A
0.16 - 0.25A	EWT002A
0.25 - 0.4A	EWT004A
0.35 - 0.5A	EWT005A
0.45 - 0.63A	EWT006A
0.55 - 0.8A	EWT008A
0.75 - 1A	EWT010A
0.9 - 1.3A	EWT013A
1.1 - 1.6A	EWT016A
1.4 - 2A	EWT020A
1.8 - 2.5A	EWT025A
2.3 - 3.2A	EWT032A
2.9 - 4A	EWT040A
3.5 - 4.8A	EWT048A
4.5 - 6.3A	EWT063A
5.5 - 7.5A	EWT075A
7.2 - 10A	EWT100A
9 - 12.5A	EWT125A



EWT...A

Auxiliaries for contactors EW005 and EW006

- installation mode: on the top

Description	Cat. ref.
1 NO + 1 NC	EWA011
2 NO	EWA012
2 NC	EWA013
4 NO	EWA014
3 NO + 1 NC	EWA015
2 NO + 2 NC	EWA016
1 NO + 3 NC	EWA017
4 NC	EWA018

Mechanical interlock

- installation mode: on the top

Description	Cat. ref.
for AC contactor	EWA105
for DC contactor	EWA106



Surge suppressor

- operational voltage: 24V
- type: rheostat
- surge voltage: < 3 x rated voltage
- current rating: 28.5 - 38.5mA
- drop-out time: < 40ms

Description	Cat. ref.
surge suppressor	EWA405

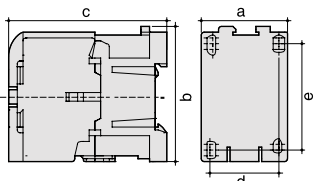

EWA405

References*		EW007	EW009	EW012	
					
Main contact					
Rated insulation voltage U_i (V)		660	660	660	
Rated operational voltage U_e (V)		660	380	660	
Thermal current I_{th} (A)		20	20	25	
Main contact rated operational current AC-3 I_e	Single pole	110V	8A / 0,37 kW	10.5A / 0.55kW	10.5A / 0.55kW
		220V	7A / 0.75kW	10A / 1.1kW	10.5A / 1.1kW
	Three pole	220/230V	7.5A / 1.5kW	10.1A / 2.2kW	12A / 3kW
		380/400V	7A / 3kW	9A / 4kW	12A / 5.5kW
		415/440V	6.5A / 3kW	-	11A / 5.5kW
		500V	5A / 3kW	-	9A / 5.5kW
		660V	4A / 3kW	-	7A / 5.5kW
Auxiliary contact					
Rated insulation voltage U_i (V)		690	690	690	
Rated operational voltage U_e (V)		600	600	600	
Thermal current I_{th} AC/DC (A)		10/2.5	10/2.5	10/2.5	
Auxiliary contact rated current I_e	AC 15	120V	6	6	6
		240V	3	3	3
		380V	1.9	1.9	1.9
		480V	1.5	1.5	1.5
	DC 13	125V	0.55	0.55	0.55
		250V	0.27	0.27	0.27
		Contactor life			
Operation frequency (cycles/hour)		1200	1200	1200	
Electrical lifespan (cycles)		1,000,000	1,000,000	1,000,000	
Mechanical lifespan (cycles)		10,000,000	10,000,000	10,000,000	
Others					
Type of auxiliary contact	NO	1	1	1	
	NC	0	0	0	
Weight (kg)		0.3	0.3	0.3	
Dimensions (mm)					
	a	45	45	45	
	b	70	70	70	
	c	82	82	82	
	d	35	35	35	
	e	55	55	55	

* **Note:** Control circuit rated operational voltage

C: 220V AC 50/60Hz	(EW007_C ~ EW300_C)	K: 240V AC 50Hz	(EW007_K ~ EW300_K)
D: 380V AC 50/60Hz	(EW007_D ~ EW300_D)	L: 400V AC 50Hz	(EW007_L ~ EW090_L)
H: 110V AC 50/60Hz	(EW007_H ~ EW090_H)	M: 415V AC 50Hz	(EW007_M ~ EW090_M)
J: 230V AC 50Hz	(EW007_J ~ EW300_J)		

EW016

EW020

EW025

EW032

EW038

EW040

660	660	660	1000	1000	1000
690	660	660	690	440	660
25	32	35	50	60	60
13.5A / 0.75 kW	19.5A / 1.1kW	25.5A / 1.5kW	35A / 1.5kW	39A / 2.2kW	37A / 2.2kW
14A / 1.5kW	20.5A / 2.2kW	26A / 3kW	35A / 3.73kW	39A / 5kW	33A / 4kW
16A / 4kW	23A / 5.5kW	27A / 7.5kW	32A / 7.5kW	39A / 11kW	42A / 11kW
16A / 7.5kW	22A / 11kW	26A / 11kW	32A / 15kW	38A / 18.5kW	40A / 20kW
15A / 7.5kW	21A / 11kW	21A / 11kW	32A / 15kW	38A / 22kW	40A / 22kW
13A / 7.5kW	19A / 11kW	21A / 11kW	22A / 18.5kW	-	35A / 22kW
10A / 7.5kW	14A / 11kW	19A / 11kW	22A / 18.5kW	-	26A / 22kW
690	690	690	690	690	690
600	600	600	660	660	600
10/2.5	10/2.5	10/2.5	10/2.5	10/2.5	10/2.5
6	6	6	6	6	6
3	3	3	3	3	3
1.9	1.9	1.9	1.9	1.9	1.9
1.5	1.5	1.5	1.5	1.5	1.5
0.55	0.55	0.55	0.55	0.55	0.55
0.27	0.27	0.27	0.27	0.27	0.27
1200	1200	1200	1200	1200	1200
1,000,000	1,000,000	1,000,000	1,000,000	1,000,000	1,000,000
10,000,000	10,000,000	10,000,000	10,000,000	10,000,000	10,000,000
1	1	1	1	1	1
0	1	1	1	1	1
0.3	0.4	0.4	0.7	0.7	0.8
45	55	55	55	58	69
70	72	72	72	94.3	99
82	92	92	92	111.7	111.7
35	45	45	45	50	60
55	55	55	55	75	80

References*

EW050



EW063



EW070



Main contact

Rated insulation voltage U_i (V)			660	660	660
Rated operational voltage U_e (V)			660	660	660
Thermal current I_{th} (A)			70	80	100
Main contact rated operational current AC-3 I_e	Single pole	110V	-	50A / 3kW	60A / 4kW
		220V	-	45A / 6kW	55A / 7.5kW
	Three pole	220/230V	55A / 15kW	65A / 18.5kW	75A / 22kW
		380/400V	55A / 25kW	64A / 30kW	72A / 37kW
		415/440V	52A / 30kW	64A / 37kW	70A / 40kW
		500V	45A / 30kW	55A / 37kW	65A / 45kW
		660V	35A / 30kW	45A / 37kW	60A / 45kW

Auxiliary contact

Rated insulation voltage U_i (V)			660	660	660
Rated operational voltage U_e (V)			600	600	600
Thermal current I_{th} AC/DC (A)			10/2.5	10/2.5	10/2.5
Auxiliary contact rated current I_e	AC 15	120V	6	6	6
		240V	3	3	3
		380V	1.9	1.9	1.9
		480V	1.5	1.5	1.5
	DC 13	125V	0.55	0.55	0.55
		250V	0.27	0.27	0.27

Contactor life

Operation frequency (cycles/hour)		1200	1200	1200
Electrical lifespan (cycles)		1,000,000	1,000,000	1,000,000
Mechanical lifespan (cycles)		10,000,000	10,000,000	10,000,000

Others

Type of auxiliary contact	NO	2	2	2
	NC	2	2	2
Weight (kg)		0.8	1.3	1.3

Dimensions (mm)

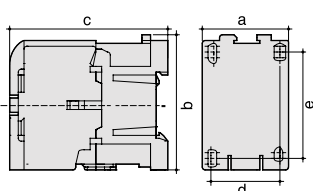







a	93.5	93.5	93.5
b	116	116	150 (with Cu terminals)
c	123	123	123
d	80	80	80
e	90	90	90

* **Note:** Control circuit rated operational voltage should be given as suffix EW0xx_x

C: 220V AC 50/60Hz (EW007_C ~ EW300_C)
 D: 380V AC 50/60Hz (EW007_D ~ EW300_D)
 H: 110V AC 50/60Hz (EW007_H ~ EW090_H)
 J: 230V AC 50Hz (EW007_J ~ EW300_J)

K: 240V AC 50Hz (EW007_K ~ EW300_K)
 L: 400V AC 50Hz (EW007_L ~ EW090_L)
 M: 415V AC 50Hz (EW007_M ~ EW090_M)

EW090	EW115	EW138	EW150	EW180	EW220	EW300
						
1000	1000	1000	1000	1000	1000	1000
690	690	690	690	690	690	690
135	135	150	200	240	260	350
-	-	-	-	-	-	-
-	-	-	-	-	-	-
85A / 25kW	115A / 30kW	138A / 40kW	150A / 45kW	182A / 55kW	225A / 65kW	300A / 90kW
85A / 45kW	115A / 60kW	138A / 75kW	147A / 80kW	179A / 95kW	225A / 120kW	300A / 160kW
85A / 51kW	105A / 60kW	135A / 75kW	131A / 80kW	178A / 100kW	220A / 132kW	300A / 160kW
80A / 55kW	93A / 65kW	105A / 75kW	129A / 90kW	156A / 110kW	190A / 132kW	250A / 160kW
50A / 45kW	75A / 65kW	85A / 75kW	107A / 100kW	118A / 110kW	140A / 132kW	220A / 220kW
660	660	660	660	660	660	660
600	660	660	660	660	660	660
10/2.5	10/2.5	10/2.5	10/2.5	10/2.5	10/2.5	10/2.5
6	6	6	6	6	6	6
3	3	3	3	3	3	3
1.9	1.9	1.9	1.9	1.9	1.9	1.9
1.5	1.5	1.5	1.5	1.5	1.5	1.5
0.55	0.55	0.55	0.55	0.55	0.55	0.55
0.27	0.27	0.27	0.27	0.27	0.27	0.27
1200	1200	1200	1200	1200	1200	1200
1,000,000	1,000,000	1,000,000	1,000,000	1,000,000	1,000,000	1,000,000
10,000,000	10,000,000	10,000,000	10,000,000	10,000,000	10,000,000	10,000,000
2	2	2	2	2	2	2
2	2	2	2	2	2	2
1.3	1.9	1.9	4.1	4.1	6.7	6.7
93.5	100	100	130	130	146	146
150 (with Cu terminals)	139	139	180	180	210	210
123	133	133	157.2	157.2	183.2	183.2
80	83	83	100	100	133	133
90	110	110	130	130	150	150

References*

EW400



EW500



EW630



Main contact

Rated insulation voltage U_i (V)			1000	1000	1000
Rated operational voltage U_e (V)			690	690	690
Thermal current I_{th} (A)			500	700	750
Main contact rated operational current AC-3 I_e	Single pole	110V	-	-	-
		220V	-	-	-
	Three pole	220/230V	400A / 110kW	500A / 150kW	630A / 200kW
		380/400V	400A / 200kW	500A / 257kW	630A / 335kW
		415/440V	400A / 220kW	430A / 257kW	600A / 355kW
		500V	375A / 257kW	410A / 280kW	525A / 355kW
		660V	330A / 300kW	355A / 335kW	460A / 450kW
690V	330A / 300kW	355A / 335kW	460A / 450kW		

Auxiliary contact

Rated insulation voltage U_i (V)			690	690	690
Rated operational voltage U_e (V)			660	660	660
Thermal current I_{th} AC/DC (A)			10/2.5	10/2.5	10/2.5
Auxiliary contact rated current I_e	AC 15	120V	6	6	6
		240V	3	3	3
		380V	1.9	1.9	1.9
		480V	1.5	1.5	1.5
		DC 13	125V	0.55	0.55
		250V	0.27	0.27	0.27

Contactor life

Operation frequency (cycles/hour)			1200	1200	1200
Electrical lifespan (cycles)			500,000	500,000	500,000
Mechanical lifespan (cycles)			1,000,000	1,000,000	1,000,000

Others

Type of auxiliary contact	NO	2	2	2	
	NC	2	2	2	
Weight (kg)			10.8	10.8	17.4

Dimensions (mm)

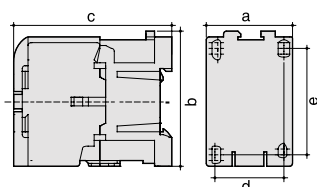

a	233	233	309
b	238	238	304
c	232	232	255
d	170	170	170
e	180	180	180

Thermal overload relays for contactors EW007 to EW032

Setting range	Cat. ref.
0.1 - 0.16A	EWT001B
0.16 - 0.25A	EWT002B
0.35 - 0.5A	EWT005B
0.45 - 0.63A	EWT006B
0.55 - 0.8A	EWT008B
0.9 - 1.3A	EWT013B
1.1 - 1.6A	EWT016B
1.4 - 2A	EWT020B
1.8 - 2.5A	EWT025B
2.3 - 3.2A	EWT032B
2.9 - 4A	EWT040B
3.5 - 4.8A	EWT048B
4.5 - 6.3A	EWT063B
5.5 - 7.5A	EWT075B
7.2 - 10A	EWT100B
9 - 12.5A	EWT125B
11.3 - 16A	EWT160B
15 - 20A	EWT200B
17.5 - 21.5A	EWT215B
21 - 25A	EWT250B
24.5 - 30A	EWT300B



EWT...B

Thermal overload relays for contactors EW038

Setting range	Cat. ref.
15 - 20A	EWT200C
17.5 - 21.5A	EWT215C
21 - 25A	EWT250C
24.5 - 30A	EWT300C
29 - 36A	EWT360C
33 - 38A	EWT380C

Thermal overload relays for contactors EW020 to EW032

Setting range	Cat. ref.
17 - 25A	EWT250D

Thermal overload relays for contactors EW040

Setting range	Cat. ref.
17 - 25A	EWT250E
24.5 - 36A	EWT360E
35 - 47A	EWT470E



EWT...E



EWT...G

Thermal overload relays for contactors EW050 to EW070

Setting range	Cat. ref.
24.5 - 36A	EWT360G
35 - 47A	EWT470G
45 - 60A	EWT600G
58 - 75A	EWT750G
72 - 90A	EWT900G

Thermal overload relays for contactors EW038

Setting range	Cat. ref.
17 - 25A	EWT250H
24.5 - 36A	EWT360H
35 - 47A	EWT470H



EWT...F

Separated thermal overload relays

- connection with wires

Setting range	Cat. ref.
17 - 25A	EWT250F
24.5 - 36A	EWT360F
35 - 47A	EWT470F
45 - 60A	EWT600F
58 - 75A	EWT750F
72 - 90A	EWT900F



EWA601

Current transformers

Description	Cat. ref.
ratio: 150A /5A	EWA601
ratio: 250A /5A	EWA602
ratio: 350A /5A	EWA603



EWA501

Guide rails

- for assembly of thermal relays

Description	Cat. ref.
for EWTxxxB series	EWA501



Product mix

Setting range	Current transformer + base + thermal overload relay	Cat. ref.
87 - 120A	EWA601 + EWA501 + EWT040B	
105 - 144A	EWA601 + EWA501 + EWT048B	
135 - 150A	EWA601 + EWA501 + EWT063B	
175 - 240A	EWA602 + EWA501 + EWT048B	
225 - 250A	EWA602 + EWA501 + EWT063B	
245 - 336A	EWA603 + EWA501 + EWT048B	

Auxiliary contacts for contactors EWA007 to EW070

- installation on the top

Description	Cat. ref.
1 NO + 1 NC	EWA001
2 NO	EWA002
2 NC	EWA003
4 NO	EWA004
4 NC	EWA005
3 NO + 1 NC	EWA006
2 NO + 2 NC	EWA007
1 NO + 3 NC	EWA008



EWA001



EWA007

Auxiliary contacts for contactors EWA007 to EW040

- installation on the side

Description	Cat. ref.
1 NO + 1 NC	EWA009



EWA009

Auxiliary contacts for contactors EWA007 to EW300

- installation on the side

Description	Cat. ref.
1 NO + 1 NC	EWA010

Mechanical interlocks

Description	Cat. ref.
for EW007 to EW032	EWA101
for EW038 to EW070	EWA103
for EW100 to EW300	EWA104



EWA101



EWA104

Mechanical and electrical interlocks

- rated insulation voltage U_i : 690V
- rated operation voltage U_e : 600V
- conventional thermal current I_{th} AC1: 10A
- type of contact: 2 NC
- minimum current: DC24V 5mA

Description	Cat. ref.
for EW007 to EW032	EWA102



EWA102

Surge suppressors for EW007 to EW120

- type: rheostat
- surge voltage: $< 3 \times$ rated voltage
- drop-out time: < 40 ms

Current rating	Operational voltage	Cat. ref.
28.5 - 38.5mA	24V	EWA401
56.5 - 76.5mA	48V	EWA402
36.1 - 48.9mA	110V	EWA403
23.1 - 31.1mA	220V	EWA404



EWA401

Contactors are power devices necessary for the remote switching and control of power circuits like heating circuits, lighting, ventilation, etc...

It is recommended to associate them with command and energy management devices (time switches, thermostats, delay timers, etc...)

Technical data

- standard contactors range: 1, 2 and 3 module width
- power contacts rating: 230V AC or 400V AC, 50/60Hz
- without manual override control
- ratings: 16A, 25A, 40A, 63A
- coil voltage rating: 12V, 24V, 110/127V, 230V AC
- utilisation categories: AC-7a / AC-1, AC-7b / AC-3

Connection capacities

- for 16A, 25A contactors:
 - 10mm² rigid conductor
 - 6mm² flexible conductor
- for 40A, 63A contactors:
 - 25mm² rigid conductor
 - 16mm² flexible conductor
- for coil connection:
 - 10mm² rigid conductor
 - 6mm² flexible conductor

Complies with IEC 61095

Recommendations

- the use of LZ060 (heat dissipation inserts) is strongly recommended every 2 contactors mounted in a row or between contactors and adjacent devices
- the use of the auxiliary contact ESC080 is not compatible with 1 module width low noise contactors



ESC225



ESC425

230V AC - 50 Hz control coil voltage





Contact types	Symbol	Power contact rating	Width in module 17.5 mm	Pack qty	Cat. ref.
1NO		25A	1	12	ESC125
1NC		25A	1	12	ESC126
2NO		25A	1	12	ESC225
		40A	3	4	ESC240
		63A	3	4	ESC263
2NC		25A	1	12	ESC226
		40A	3	4	ESC241
		63A	3	4	ESC264
1NO + 1NC		25A	1	12	ESC227
3NO		25A	2	6	ESC325
		40A	3	4	ESC340
		63A	3	4	ESC363
4NO		25A	2	6	ESC425
		40A	3	4	ESC440
		63A	3	4	ESC463
4NC		25A	2	6	ESC426
		40A	3	4	ESC441
		63A	3	4	ESC464
2NO + 2NC		25A	2	6	ESC427
		40A	3	4	ESC442
		63A	3	4	ESC465
3NO + 1NC		25A	2	6	ESC428
		40A	3	4	ESC443
		63A	3	4	ESC466

110/127V AC - 50 Hz control coil voltage

Contact types	Symbol	Power contact rating	Width in module 17.5 mm	Pack qty	Cat. ref.
2NO		25A	1	12	ESM225
1NO + 1NC		25A	1	12	ESM227
4NO		40A	3	4	ESM440

ESM225



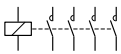
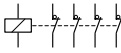
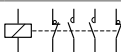
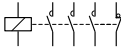

24V AC - 50 Hz control coil voltage

Contact types	Symbol	Power contact rating	Width in module 17.5 mm	Pack qty	Cat. ref.
1NO		25A	1	12	ESD125
2NO		25A	1	12	ESD225
		40A	3	4	ESD240
		63A	3	4	ESD263
2NC		25A	1	12	ESD226
		40A	3	4	ESD241
		63A	3	4	ESD264
1NO + 1NC		25A	1	12	ESD227
4NO		25A	2	6	ESD425
		40A	3	4	ESD440
		63A	3	4	ESD463
4NC		25A	2	6	ESD426
		63A	3	4	ESD464
2NO + 2NC		25A	2	6	ESD427
3NO + 1NC		25A	2	6	ESD428



ESD263

12V AC - 50 Hz control coil voltage

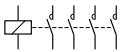
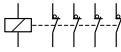
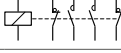
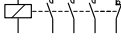
Contact types	Symbol	Power contact rating	Width in module 17.5 mm	Pack qty	Cat. ref.
1NO		25A	1	12	ESL125
2NO		25A	1	12	ESL225
		40A	3	4	ESL240
		63A	3	4	ESL263
2NC		25A	1	12	ESL226
		40A	3	4	ESL241
		63A	3	4	ESL264
1NO + 1NC		25A	1	12	ESL227
4NO		25A	2	6	ESL425
		40A	3	4	ESL440
		63A	3	4	ESL463
4NC		25A	2	6	ESL426
2NO + 2NC		25A	2	6	ESL427
3NO + 1NC		25A	2	6	ESL428



ESL440

Accessories

Description	Pack qty	Cat. ref.
terminal shrouds for 1 module width contactors	10	ESC001
terminal shrouds for 2 module width contactors	10	ESC002
terminal shrouds for 3 module width contactors	10	ESC003
1NO + 1NC auxiliary contact for 1, 2 and 3 modules width contactors, 6A in AC12, 2A in AC15	1	ESC080
1/2 module width heat dissipation insert	12	LZ060



ESC001



ESC080

Contactors are power devices necessary for the remote switching and control of power circuits like heating circuits, lighting, ventilation, etc...

It is recommended to associate them with command and energy management devices (time switches, thermostats, delay timers, etc...)

The low noise version is recommended in every areas where silent functioning is required.

Technical data

- low noise contactors range: 1, 2 and 3 module width
- power contacts rating: 230V AC or 400V AC, 50/60Hz
- without manual override control
- ratings: 16A, 25A, 40A, 63A
- coil voltage rating: 12V, 24V, 110/127V, 230V AC
- utilisation categories: AC-7a / AC-1, AC-7b / AC-3

Recommendations

- the use of LZ060 (heat dissipation inserts) is strongly recommended between each low noise contactors or between low noise contactors and adjacent devices
- the use of the auxiliary contact ESC080 is not compatible with 1 module width low noise contactors

Connection capacities

- for 16A, 25A contactors:
 - 10mm² rigid conductor
 - 6mm² flexible conductor
- for 40A, 63A contactors:
 - 25mm² rigid conductor
 - 16mm² flexible conductor
- for coil connection:
 - 10mm² rigid conductor
 - 6mm² flexible conductor

Complies with IEC 61095



ESC225S



ESC425S



ESC463S

230V AC - 50 Hz control coil voltage

Contact types	Symbol	Power contact rating	Width in module 17.5 mm	Pack qty	Cat. ref.
1NO		25A	1	12	ESC125S
2NO		25A	1	12	ESC225S
		40A	3	4	ESC240S
		63A	3	4	ESC263S
3NO		25A	2	6	ESC325S
		40A	3	4	ESC340S
		63A	3	4	ESC363S
3NC		25A	2	6	ESC326S
4NO		25A	2	6	ESC425S
		40A	3	4	ESC440S
		63A	3	4	ESC463S
4NC		25A	2	6	ESC426S
2NO + 2NC		25A	2	6	ESC427S
3NO + 1NC		25A	2	6	ESC428S

24V AC - 50 Hz control coil voltage

Contact types	Symbol	Power contact rating	Width in module 17.5 mm	Pack qty	Cat. ref.
1NO		25A	1	12	ESD125S
2NO		25A	1	12	ESD225S
		40A	3	4	ESD240S
		63A	3	4	ESD263S
3NO		25A	2	6	ESD325S
3NC		25A	2	6	ESD326S
4NO		25A	2	6	ESD425S
		40A	3	4	ESD440S
		63A	3	4	ESD463S
4NC		25A	2	6	ESD426S
2NO + 2NC		25A	2	6	ESD427S
3NO + 1NC		25A	2	6	ESD428S



ESD463S

12V AC - 50 Hz control coil voltage

Contact types	Symbol	Power contact rating	Width in module 17.5 mm	Pack qty	Cat. ref.
2NO		40A	3	4	ESL240S
		63A	3	4	ESL263S
4NO		40A	3	4	ESL440S
		63A	3	4	ESL463S



ESL463S

Accessories

Description	Pack qty	Cat. ref.
terminal shrouds for 1 module width contactors	10	ESC001
terminal shrouds for 2 module width contactors	10	ESC002
terminal shrouds for 3 module width contactors	10	ESC003
1NO+1NC auxiliary contact for 1, 2 and 3 modules width contactors, 6A in AC12, 2A in AC15 (not compatible with 1 module width low noise contactors)	1	ESC080
1/2 module width heat dissipation insert	12	LZ060



ESC001



ESC080

Contactors are power devices necessary for the remote switching and control of power circuits like heating circuits, lighting, ventilation, etc...

It is recommended to associate them with command and energy management devices (time switches, thermostats, delay timers, etc...)

Technical data

- standard contactors range: 1, 2 and 3 module width
- power contacts rating: 230V AC or 400V AC, 50/60Hz
- without manual override control,
- ratings: 16A, 25A, 40A, 63A
- coil voltage rating: 12V, 24V, 110/127V, 230V AC
- utilisation categories: AC-7a / AC-1, AC-7b / AC-3

Connection capacities

- for 16A, 25A contactors:
10mm² rigid conductor
6mm² flexible conductor
- for 40A, 63A contactors:
25mm² rigid conductor
16mm² flexible conductor
- for coil connection:
10mm² rigid conductor
6mm² flexible conductor

Complies with IEC 61095

Recommendations

- the use of LZ060 (heat dissipation inserts) is strongly recommended every 2 contactors mounted in a row or between contactors and adjacent devices
- the use of the auxiliary contact ESC080 is not compatible with 1 module width low noise contactors



ERC225



ERC263



ERC425

230V AC - 50 Hz control coil voltage

Contact types	Symbol	Power contact rating	Width in module 17.5 mm	Pack qty	Cat. ref.
1NO		25A	1	12	ERC125
2NO		16A	1	12	ERC216
		25A	1	12	ERC225
		40A	3	4	ERC240
		63A	3	4	ERC263
2NC		16A	1	12	ERC217
		25A	1	12	ERC226
3NO		16A	2	6	ERC316
		25A	2	6	ERC325
4NO		16A	2	6	ERC416
		25A	2	6	ERC425
4NC		25A	2	6	ERC426
2NO + 2NC		16A	2	6	ERC418
		25A	2	6	ERC427
3NO + 1NC		25A	2	6	ERC428



ERD218

24V AC - 50 Hz control coil voltage

Contact types	Symbol	Power contact rating	Width in module 17.5 mm	Pack qty	Cat. ref.
2NO		16A	1	12	ERD216
		25A	1	12	ERD225
		40A	3	4	ERD240
		63A	3	4	ERD263
2NC		16A	1	12	ERD217
1NO + 1NC		16A	1	12	ERD218
2NO + 2NC		25A	2	6	ERD418
4NO		25A	2	6	ERD425

12V AC - 50 Hz control coil voltage

Contact types	Symbol	Power contact rating	Width in module 17.5 mm	Pack qty	Cat. ref.
2NO		16A	1	12	ERL216
		25A	1	12	ERL225
		40A	3	4	ERL240
		63A	3	4	ERL263
2NC		16A	1	12	ERL217
1NO + 1NC		16A	1	12	ERL218
2NO + 2NC		25A	2	6	ERL418
4NO		25A	2	6	ERL425



ERL225

Accessories

Description	Pack qty	Cat. ref.
terminal shrouds for 1 module width contactors	10	ESC001
terminal shrouds for 2 module width contactors	10	ESC002
terminal shrouds for 3 module width contactors	10	ESC003
1NO+1NC auxiliary contact for 1, 2 and 3 modules width contactors, 6A in AC12, 2A in AC15	1	ESC080
1/2 module width heat dissipation insert	12	LZ060



ESC001



ESC080

Contactors are power devices necessary for the remote switching and control of power circuits like heating circuits, lighting, ventilation, etc...

It is recommended to associate them with command and energy management devices (time switches, thermostats, delay timers, etc...)

The low noise version is recommended in every areas where silent functioning is required.

Technical data

- low noise contactors range: 1, 2 and 3 module width,
- power contacts rating: 230V AC or 400V AC, 50/60Hz,
- without manual override control,
- ratings: 16A, 25A, 40A, 63A,
- coil voltage rating: 12V, 24V, 110/127V, 230V AC,
- utilisation categories: AC-7a / AC-1, AC-7b / AC-3.

Connection capacity:

- for 16A, 25A contactors:
10mm² rigid conductor
6mm² flexible conductor
- for 40A, 63A contactors:
25mm² rigid conductor
16mm² flexible conductor
- for coil connection:
10mm² rigid conductor
6mm² flexible conductor

Complies with IEC 61095

Recommendations:

- the use of LZ060 (heat dissipation inserts) is strongly recommended between each low noise contactors or between low noise contactors and adjacent devices.
- the use of the auxiliary contact ESC080 is not compatible with 1 module width low noise contactors.



ERC225S

230V AC - 50 Hz control coil voltage

Contact types	Symbol	Power contact rating	Width in module 17.5 mm	Pack qty	Cat. ref.
1NO		25A	1	12	ERC125S
2NO		25A	1	12	ERC225S
		40A	3	4	ERC240S
4NO		25A	2	6	ERC425S

24V AC - 50 Hz control coil voltage

Contact types	Symbol	Power contact rating	Width in module 17.5 mm	Pack qty	Cat. ref.
2NO		25A	1	12	ERD225S
		40A	3	4	ERD240S
		63A	3	4	ERD263S
2NO + 2NC		25A	2	6	ERD418S



ERL263S

12V AC - 50 Hz control coil voltage

Contact types	Symbol	Power contact rating	Width in module 17.5 mm	Pack qty	Cat. ref.
2NO		40A	3	4	ERL240S
		63A	3	4	ERL263S



ESC001



ESC080

Accessories

Description	Pack qty	Cat. ref.
terminal shrouds for 1 module width contactors	10	ESC001
terminal shrouds for 2 module width contactors	10	ESC002
terminal shrouds for 3 module width contactors	10	ESC003
1NO+1NC auxiliary contact for 1, 2 and 3 modules width contactors, 6A in AC12, 2A in AC15 (not compatible with 1 module width low noise contactors)	1	ESC080
1/2 module width heat dissipation insert	12	LZ060

Contactors are power devices necessary for the remote switching and control of power circuits like heating circuits, lighting, ventilation, etc...

It is recommended to associate them with command and energy management devices (time switches, thermostats, delay timers, etc...)

The DC control voltage version is recommended in some application when continuous current functioning is required.

Technical data

- DC control voltage use contactors range: 1, 2 and 3 module width
- power contacts rating: 230V AC or 400V AC
- with and without manual override control
- ratings: 16A, 25A, 40A, 63A
- coil voltage rating: 12V, 24V
- utilisation category: AC-7a / AC-1, AC-7b / AC-3

Recommendations

- the use of LZ060 (heat dissipation inserts) is strongly recommended between each low noise contactors or between low noise contactors and adjacent devices.
- the use of the auxiliary contact ESC080 is not compatible with 1 module width low noise contactors.

Connection capacity

- for 16A, 25A contactors:
 - 10mm² rigid conductor
 - 6mm² flexible conductor
- for 40A, 63A contactors:
 - 25mm² rigid conductor
 - 16mm² flexible conductor
- for coil connection:
 - 10mm² rigid conductor
 - 6mm² flexible conductor

Complies with IEC 61095

12V DC - 50 Hz control coil voltage, without override

Contact types	Symbol	Power contact rating	Width in module 17.5 mm	Pack qty	Cat. ref.
2NO		25A	1	12	ESL225SDC
		40A	3	4	ESL240S
		63A	3	4	ESL263S
3NC		25A	2	6	ESL326SDC
4NO		25A	2	6	ESL425SDC
		40A	3	4	ESL440S
		63A	3	4	ESL463S
4NC		25A	2	6	ESL426SDC
2NO + 2NC		25A	2	6	ESL427SDC
3NO + 1NC		25A	2	6	ESL428SDC



ESL463S

24V DC - 50 Hz control coil voltage, without override

Contact types	Symbol	Power contact rating	Width in module 17.5 mm	Pack qty	Cat. ref.
2NO		40A	3	4	ESD240S
		63A	3	4	ESD263S
4NO		25A	2	6	ESD425SDC
		40A	3	4	ESD440S
		63A	3	4	ESD463S



ESD463S



ERL263S

12V DC - 50 Hz control coil voltage, with override

Contact types	Symbol	Power contact rating	Width in module 17.5 mm	Pack qty	Cat. ref.
2NO		25A	1	12	ERL625SDC
		40A		4	ERL240S
		63A	3	4	ERL263S
4NO		25A	2	6	ERL425SDC
2NO + 2NC		16A	2	6	ERL418SDC

24V DC - 50 Hz control coil voltage, with override

Contact types	Symbol	Power contact rating	Width in module 17.5 mm	Pack qty	Cat. ref.
2NO		25A	1	12	ERD225SDC
		40A	3	4	ERD240S
		63A	3	4	ERD263S



ESC001



ESC080

Accessories

Description	Pack qty	Cat. ref.
terminal shrouds for 1 module width contactors	10	ESC001
terminal shrouds for 2 module width contactors	10	ESC002
terminal shrouds for 3 module width contactors	10	ESC003
1NO+1NC auxiliary contact for 1, 2 and 3 modules width contactors, 6A in AC12, 2A in AC15 (not compatible with 1 module width low noise contactors)	1	ESC080
1/2 module width heat dissipation insert	12	LZ060

To provide all types of automatic control i.e. lighting, ventilation, watering, machine pre-heating, automatic door and visual audible indication, cycle control etc.
For timing and automation in domestic and commercial premises. The input signal can be via various switching devices (pushbutton, latching switch, timeclock etc) and the timed output used to control the application.

Connection capacity

6mm² max rigid
1.5 - 10mm² flexible

Complies with - EN 60669-1, EN 60669-2-1

Technical data

- voltage supply range:
12 and 24 to 48V DC
12 and 24 to 230V AC
- adjustable time delay: from 0.1s to 10hrs
- LED indicator frequency: 50/60 Hz
- 1 potential free changeover contact
- breaking capacity: 8A / 230V AC

Modular delay timers

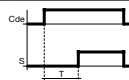
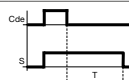
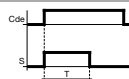
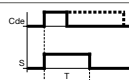
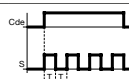
Description		Width in module 17.5 mm	Pack qty	Cat. ref.
delay on		1	1	EZN001
delay off		1	1	EZN002
adjustable time on		1	1	EZN003
timer		1	1	EZN004
symmetrical flasher		1	1	EZN005
multifunction 6 individual functions including: delay on, delay off, timer,...		1	1	EZN006



EZN001



EZN006

To interface between low voltage and very low voltage circuits to ensure galvanic isolation between LV and VLV to 4kV.

Application

Interface between fire alarm, burglar alarm and other VLV systems and main distribution circuits.

Connection capacity

- 4 mm² flexible
- 6 mm² rigid.



EN145

Interface relay VLV/LV 1 way

- coil voltage: 10 to 26 V AC/DC
- consumption: 75 mA to 120 mA
- output: 1 changeover contact
max. 5 A - 250 V AC
min. 10 mA - 12 V DC

Description	Width in module 17.5 mm	Pack qty	Cat. ref.
interface relays VLV/LV 1 way	1	1	EN145

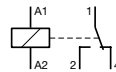

Interface relay LV/VLV 1 way

- coil voltage: 230V AC 50Hz
- output: 1 changeover contact
max. 5 A - 250 V AC
min. 10 mA - 12 V DC

Description	Width in module 17.5 mm	Pack qty	Cat. ref.
interface relays LV/VLV 1 way	1	1	EN146

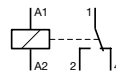

EN175

Collective safety device relay

- for motorized gas combustion extraction system
- coil voltage: 230V AC 50Hz
- output: 1 changeover contact
max. 5 A - 250 V AC
min. 10 mA - 12 V DC

Description	Width in module 17.5 mm	Pack qty	Cat. ref.
collective safety device relay	1	1	EN175

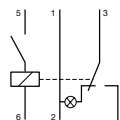

Permits the remote control of a lighting circuits from several points using push-buttons in private buildings, small industry buildings and administration buildings. Latching relays operate when impulsed by a signal voltage. The impulse can be provided via a push button or switch. The first pulse operates the relay and latches it into its set (opposite) state, the next operation of the push button returns the relay into its reset (original) state.

Technical data

- nominal voltage of the power circuit: $U_n = 250/400$ V AC
- nominal voltage of the power circuit: 12V, 24V, 48V and 230 V AC
- nominal voltage of the control circuit: 12V, 24V, 110V DC

- conventional thermal current: 16A AC1
- control and power circuits
- nominal frequency: 50/60Hz
- contact types: 1NO, 2NO, 1NC+1NO, 4NO, 2NO+2NC, 3NO+1NC
- 4 types of auxiliaries
- connection capacity:
rigid 10 mm²
flexible 6 mm²

Complies with IEC 60 669-1 and IEC 60 669-2-2.

Latching relays

Contact types	Symbol	Coil V AC 50/60 Hz	Coil V DC	Power circuit AC1	Width in module 17.5 mm	Pack qty	Cat. ref.
1NO		230	110	16A-250V	1	12	EPN510
		48	24	16A-250V	1	1	EPN501
		24	12	16A-250V	1	1	EPN513
		12	-	16A-250V	1	1	EPN511
2NO		230	110	16A-250V	1	1	EPN520
		48	24	16A-250V	1	1	EPN526
		24	12	16A-250V	1	1	EPN524
		12	-	16A-250V	1	1	EPN521
1NC + 1NO		230	110	16A-250V	1	1	EPN515
		110	48	16A-250V	1	1	EPN516
		48	24	16A-250V	1	1	EPN503
		24	12	16A-250V	1	1	EPN518
		12	-	16A-250V	1	1	EPN519
4NO		230	110	16A-400V	2	1	EPN540
		48	24	16A-400V	2	1	EPN548
		24	12	16A-400V	2	1	EPN541
2NC + 2NO		230	110	16A-250V	2	1	EPN525
		24	12	16A-250V	2	1	EPN528
3NO + 1NC		230	110	16A-400V	2	1	EPN546



EPN510



EPN540

Several auxiliaries can be combined with the latching relay. The latching relays are built to add as an option the following auxiliaries:

- an auxiliary for centralised ON/OFF control EPN050
- an auxiliary contact for remote signalling EPN051
- an auxiliary for multi levelled centralised control EPN052
- an auxiliary for control by maintained contact EPN053.

Technical data

- voltage supply: 24 to 230V AC
- 4 types auxiliaries
- connection capacity:
rigid 10 mm²
flexible 6 mm²

Complies with IEC 60 669-1 and IEC 60 669-2-2



EPN050

Auxiliary for centralised control

- 110V to 230V AC
- the EPN050 allows the centralised control of several light sources which can be turned on or off simultaneously

- the separate switching by pushing the pushbuttons, which are connected with the latching relay, remains possible

Description		Width in module 17.5 mm	Pack qty	Cat. ref.
auxiliary for centralised control		0.5	1	EPN050



EPN051

Auxiliary contact

- 2A - 250 V AC
- a remote signalling can be realised with the auxiliary contact EPN051

Description		Width in module 17.5 mm	Pack qty	Cat. ref.
auxiliary contact		0.5	1	EPN051



EPN052

Auxiliary for multi levelled centralised control

- 110V to 230V AC
- the EPN052 allows a generic central control of individual central on/off EPN050

Description		Width in module 17.5 mm	Pack qty	Cat. ref.
auxiliary for multi levelled centralised control		0.5	1	EPN052



EPN053

Auxiliary for control by maintained contact

- 24V to 230V AC
- when control devices with permanent impulse are externally driven, e.g. time switches or limit switches, an impulse control directly to the latching relay's coil is possible with the auxiliary contact EPN053

Description		Width in module 17.5 mm	Pack qty	Cat. ref.
auxiliary for control by maintained contact		0.5	1	EPN053

Switch disconnectors are used as general switches in electrical low voltage distribution boards and for the isolation of loads during the interventions of maintenance.

Technical data

- 3 sizes are available:
 - Size 1: In 16 A, 25 A, 32 A
 - Size 2: In 32 A, 40 A, 63 A
 - Size 3: In 63 A, 80 A, 100 A, 125 A
- 230/400V 50/60 Hz
- utilisation category AC22A from 16A to 125A for mixed alternative load (inductive and resistive)
- version with light indicator in 1 and 2 poles from 16 to 32A
- IP2X with terminal shrouds
- all switches have a green/red indication on the toggle giving positive contact position
- MZN175 padlocking kit allows to lock in the ON and OFF position

Connection capacity

- Size 1: In 16 A, 25 A, 32 A
 - 16 mm² rigid conductor
 - 10 mm² flexible conductor
- Size 2: In 32 A, 40 A, 63 A
 - 25 mm² rigid conductor
 - 16 mm² flexible conductor
- Size 3: In 63 A, 80 A, 100 A, 125 A
 - 50 mm² rigid conductor
 - 35 mm² flexible conductor

Complies with

- IEC 60 669-1, IEC 60 669-2-4, IEC 60 947-3 for the size 1
- IEC 60 669-2-4, IEC 60 947-3 for the size 2
- IEC 60 947-3 for the size 3

Single pole switch disconnectors

Size	Characteristics	Width in module 17.5 mm	Pack qty	Cat. ref.
1	1 x 16 A - 250 V AC	1	12	SBN116
	1 x 25 A - 250 V AC	1	12	SBN125
	1 x 32 A - 250 V AC	1	12	SBN132
2	1 x 32 A - 250 V AC	1	12	SBN133
	1 x 40 A - 250 V AC	1	12	SBN140
	1 x 63 A - 250 V AC	1	12	SBN163
3	1 x 63 A - 250 V AC	1	12	SBN164
	1 x 80 A - 250 V AC	1	12	SBN180
	1 x 100 A - 250 V AC	1	12	SBN190
	1 x 125 A - 250 V AC	1	12	SBN199



SBN163



Double pole switch disconnectors

Size	Characteristics	Width in module 17.5 mm	Pack qty	Cat. ref.
1	2 x 16 A - 250 V AC	1	12	SBN216
	2 x 25 A - 250 V AC	1	12	SBN225
	2 x 32 A - 250 V AC	1	12	SBN232
2	2 x 32 A - 250 V AC	2	6	SBN233
	2 x 40 A - 250 V AC	2	6	SBN240
	2 x 63 A - 250 V AC	2	6	SBN263
3	2 x 63 A - 250 V AC	2	6	SBN264
	2 x 80 A - 250 V AC	2	6	SBN280
	2 x 100 A - 250 V AC	2	6	SBN290
	2 x 125 A - 250 V AC	2	6	SBN299



SBN263





SBN363

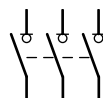

Three pole switch disconnectors

Size	Characteristics	Width in module 17.5 mm	Pack qty	Cat. ref.
1	3 x 16 A - 250 V AC	2	6	SBN316
	3 x 25 A - 250 V AC	2	6	SBN325
	3 x 32 A - 250 V AC	2	6	SBN332
2	3 x 32 A - 250 V AC	3	4	SBN333
	3 x 40 A - 250 V AC	3	4	SBN340
	3 x 63 A - 250 V AC	3	4	SBN363
3	3 x 63 A - 250 V AC	3	4	SBN364
	3 x 80 A - 250 V AC	3	4	SBN380
	3 x 100 A - 250 V AC	3	4	SBN390
	3 x 125 A - 250 V AC	3	4	SBN399



SBN463

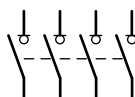

Four pole switch disconnectors

Size	Characteristics	Width in module 17.5 mm	Pack qty	Cat. ref.
1	4 x 16 A - 250 V AC	2	6	SBN416
	4 x 25 A - 250 V AC	2	6	SBN425
	4 x 32 A - 250 V AC	2	6	SBN432
2	4 x 32 A - 250 V AC	4	3	SBN433
	4 x 40 A - 250 V AC	4	3	SBN440
	4 x 63 A - 250 V AC	4	3	SBN463
3	4 x 63 A - 250 V AC	4	3	SBN464
	4 x 80 A - 250 V AC	4	3	SBN480
	4 x 100 A - 250 V AC	4	3	SBN490
	4 x 125 A - 250 V AC	4	3	SBN499



SBB116

Single pole switch disconnectors with indicator light

Size	Characteristics	Width in module 17.5 mm	Pack qty	Cat. ref.
1	1 x 16 A - 250 V AC	1	1	SBB116
	1 x 25 A - 250 V AC	1	1	SBB125
	1 x 32 A - 250 V AC	1	1	SBB132



SBB225

Double pole switch disconnectors with indicator light

Size	Characteristics	Width in module 17.5 mm	Pack qty	Cat. ref.
1	2 x 16 A - 250 V AC	1	1	SBB216
	2 x 25 A - 250 V AC	1	1	SBB225
	2 x 32 A - 250 V AC	1	1	SBB232



ESC080

Accessories

Description	Pack qty	Cat. ref.
auxiliary contact compatible with switch disconnectors from 16 to 125 A, 6 A, 230 V AC	1	ESC080
terminal shroud for switches 32 A to 125 A	4	MZN120
phase barrier shield	set of 3	MZN121
padlocking kit	1	MZN175

The changeover switch range is the solution to guarantee supply of load by controlling 2 power circuits.

Technical data

- In from 25A to 63A
- use category AC22A from 25A to 40A for mixed alternative load, inductive and resistive (AC21A for 63A)
- IP2X with terminal shrouds
- frequency 50/60 Hz

Connection capacity

- In 25 A and 40 A
 - 16 mm² rigid conductor
 - 10 mm² flexible conductor
- In 63A
 - 25 mm² rigid conductor
 - 16 mm² flexible conductor

Complies with IEC 60 669-1, IEC 60947-3

MZN175 padlocking kit allows to lock in the ON and OFF position.

1-way changeover switch and common point on top (I-II)

Size	Characteristics	Width in module 17.5 mm	Pack qty	Cat. ref.
1	1 x 25 A - 250 V AC	1	12	SFH125



SFH125



2-way changeover switch 1NO+1NC (I-II)

Size	Characteristics	Width in module 17.5 mm	Pack qty	Cat. ref.
1	1 x 25 A - 250 V AC	1	12	SFM125



SFM125



2-way changeover switch and common point on top (I-II)

Size	Characteristics	Width in module 17.5 mm	Pack qty	Cat. ref.
1	2 x 25 A - 250 V AC	1	6	SFH225

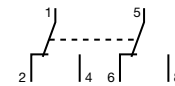

Single pole centre-off changeover switches and common point on top (I-O-II)

Size	Characteristics	Width in module 17.5 mm	Pack qty	Cat. ref.
1	1 x 25 A - 250 V AC	1	12	SFT125
	1 x 40 A - 250 V AC	1	12	SFT140



SFT125





SFT440

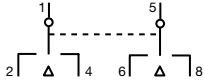

Double pole centre-off changeover switches and common point on top (I-O-II)

Size	Characteristics	Width in module 17.5 mm	Pack qty	Cat. ref.
1	2 x 25 A - 250 V AC	1	6	SFT225
	2 x 40 A - 250 V AC	1	6	SFT240
	3 x 40 A - 400 V AC	1	4	SFT340
	4 x 40 A - 400 V AC	1	3	SFT440



SFT463

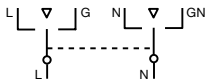

Changeover switches with centerpoint (I-O-II)

Size	Characteristics	Width in module 17.5 mm	Pack qty	Cat. ref.
1	2 x 63 A - 250 V AC	4	1	SF263
	4 x 63 A - 400 V AC	8	1	SF463



ESC080

Accessories

Description	Pack qty	Cat. ref.
Auxiliary contact		
compatible with switch disconnectors from 16 to 125 A, 6 A, 230 V AC	1	ESC080
Terminal shroud		
for switches 32 A to 125 A	4	MZN120
Phase barrier shield		
set of 3 pieces	3	MZN121
Padlocking kit		
padlocking kit	1	MZN175

Allows remote control* tripping via voltmetric tripping relay to associate on the left side of product
 - associated auxiliary: auxiliary contact (AC)
 - for the main protection in general or sub-switchboard

Connection capacity for associated auxiliary

- 0.5 to 6 mm² flexible
- 1 to 10 mm² rigid

Complies with IEC 60947-1 / IEC 60947-3. AC 23 A

Connection capacity for switch

- 6 to 16 mm² flexible
- 6 to 25 mm² rigid

2 pole switches

- U_i = 690 V AC

Characteristics	Width in module 17.5 mm	Pack qty	Cat. ref.
2 x 40 A - 250 V AC	2.5	1	SA240
2 x 63 A - 250 V AC	2.5	1	SA263
2 x 80 A - 250 V AC	2.5	1	SA280



SA263



4 pole switches

- U_i = 690 V AC

Characteristics	Width in module 17.5 mm	Pack qty	Cat. ref.
4 x 40 A - 400 V AC	4.5	1	SA440
4 x 63 A - 400 V AC	4.5	1	SA463
4 x 80 A - 400 V AC	4.5	1	SA480



SA463

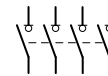

Shunt trips

- allows remote tripping of the trip free switch

Characteristics	Width in module 17.5 mm	Pack qty	Cat. ref.
230 - 415 V AC, 110 - 130 V DC	1	1	MZ203
24 - 48 V AC, 12 - 48 V DC	1	1	MZ204



MZ203



Under voltage release

- allows trip free switch to be closed only when voltage is above 70% of U_n

- trip free switch will automatically trip when voltage falls by 35% of U_n

Characteristics	Width in module 17.5 mm	Pack qty	Cat. ref.
48 V DC	1	1	MZ205
230 V AC	1	1	MZ206



MZ205





MZ212

Over voltage release

- allows trip free switch to be closed only when voltage between Ph and N is above 110/180%

Characteristics	Width in module 17.5 mm	Pack qty	Cat. ref.
230 V AC	1	1	MZ212



MZN175

Padlocking kit

- accepts 2 padlock with Ø 4,75mm shackle or 3 padlocks with Ø 3mm shackle

Characteristics	Pack qty	Cat. ref.
padlocking kit	1	MZN175

These products are used for remote controlling signalisation of any event in any electrical installation (domestic, tertiary & industrial). LED technology providing longer life, new design, integrated label holder.

Push buttons

- versions: impulse push buttons and latching push buttons,
- contact types: 1NO, 1NC, 2NO, 2NC, 1NC+1NO

Indicator lights

- light type: LED technology
- supply voltage: 12/48V AC/DC and 230/415V AC
- colors: green, red, orange, blue, clear
- range: 1,2 and 3 indicators light possibility in the same device
- power consumption: 0.8 watts
- burning hours: up to 100,000h

These versions with indicator lights are equipped with green or red diffuser. (led technology)

Connection capacity

- 10 mm² rigid,
- 6 mm² flexible

Comply with IEC 60947-5-1 and IEC 62094-1

Single indicator light

- 230 V AC

Description	Width in module 17.5 mm	Pack qty	Cat. ref.
green LED light	1	12	SVN121
red LED light	1	12	SVN122
orange LED light	1	12	SVN123
blue LED light	1	12	SVN124
clear LED light	1	12	SVN125



SVN122



Double indicator light

- 230 V AC

Description	Width in module 17.5 mm	Pack qty	Cat. ref.
green and red LED light	1	12	SVN126
clear LED light	1	12	SVN128



SVN126



Triple indicator light

- 230 V AC

Description	Width in module 17.5 mm	Pack qty	Cat. ref.
red LED light	1	12	SVN127
red/orange/green LED light	1	12	SVN129
green LED light	1	12	SVN221
red/orange/blue LED light	1	12	SVN222



SVN127



Low voltage indicator lights

- 12 to 48 V AC/DC

Description	Width in module 17.5 mm	Pack qty	Cat. ref.
green LED light	1	12	SVN131
red LED light	1	12	SVN132
orange LED light	1	12	SVN133
blue LED light	1	12	SVN134
clear LED light	1	12	SVN135
green/red LED light	1	12	SVN136



SVN134





SVN311



SVN391

Impulse push-buttons 16 A - 250 V AC

Characteristics	Symbol	Width in module 17.5 mm	Pack qty	Cat. ref.
1 NO		1	12	SVN311
1 NC		1	12	SVN321
2 NO		1	12	SVN331
2 NC		1	12	SVN341
1NO / 1 NC		1	12	SVN351
1 NO + 1 NO		1	12	SVN371
1 NC + 1 NO		1	12	SVN391



SVN411

Impulse push-buttons 16 A - 250 V AC with LED

Characteristics	Symbol	Width in module 17.5 mm	Pack qty	Cat. ref.
1 NO with 230 V AC green LED		1	12	SVN411
1 NC with 230 V AC red LED		1	12	SVN422
2 NO with 230 V AC red LED		1	12	SVN432
2 NC with 230 V AC green LED		1	12	SVN441
1 NC + 1 NO with 230 V AC red LED		1	12	SVN452







SVN461

Impulse push-buttons 16 A - 12/48 V AC/DC

Characteristics	Symbol	Width in module 17.5 mm	Pack qty	Cat. ref.
2 NO with 230 V AC green LED		1	12	SVN461
2 NO with 230 V AC red LED		1	12	SVN462



Latching push buttons 16 A - 230 V AC

Characteristics	Symbol	Width in module 17.5 mm	Pack qty	Cat. ref.
1 NO		1	12	SVN312
1 NC		1	12	SVN322
2 NO		1	12	SVN332
2 NC		1	12	SVN342
1NO / 1 NC		1	12	SVN352



SVN332



Impulse push-buttons 16 A - 250 V AC with LED

Characteristics	Symbol	Width in module 17.5 mm	Pack qty	Cat. ref.
1 NO with 230 V AC green LED		1	12	SVN413
2 NO with 230 V AC green LED		1	12	SVN433



SVN433

Impulse push-buttons 16 A - 12/48 V AC/DC

Characteristics	Symbol	Width in module 17.5 mm	Pack qty	Cat. ref.
2 NO with 230 V AC green LED		1	12	SVN463
2 NO with 230 V AC red LED		1	12	SVN464



SVN464



EE960

Emergency lighting module

- for residential and commercial premises
- installed in a consumer unit or distribution board
- the lamp can be configured to light automatically in case of power failure
- it can also be withdrawn from its base, thereby acting as a mini torch
- type of lamp: incandescent lamp
- battery charging time: 12 hours
- battery autonomy: +/- 3 hours
- life time: 500 cycles
- ingress protection degree: IP20
- connection capacity: 4 mm² flexible/rigid wire
- supply voltage: 230V AC +/-10%
- frequency: 50/60Hz
- fixing mode: DIN rail

Description	Width in module 17.5 mm	Pack qty	Cat. ref.
emergency lighting module	3	1	EE960



EE910

Remote control for emergency lightings

- the remote control is recommended in public, commercial or industrial premises.
- the device is a 2 position changeover switch, with automatic recall for switching off or on, of self contained emergency lighting, by delivering polarized current impulses on the remote control circuits (+ or -)
- supply voltage: 230V AC +/-10%
- frequency: 50/60Hz
- consumption: 0,1 mA / 6V
- fixing mode: DIN rail
- output supply: 12V and 8,4V DC
- capacity: 60 and 120 emergency lighting blocks
- connection capacity:
 - 10 mm² rigid wire
 - 6 mm² flexible wire

Description	Width in module 17.5 mm	Pack qty	Cat. ref.
for up to 60 self contained emergency lighting	4	1	EE905
for up to 120 self contained emergency lighting	4	1	EE910

Transformers ensure an electrical separation between primary and secondary circuits.
They provide extra safety low voltage 8, 12, 24 V AC

Technical data

- secondary voltages: 8 V, 12 V, 24 V AC
- bell transformers are short-circuit protected
- bells/buzzers max. continuous duty < 30 minutes
- output bells: 85 dBA
- output buzzers: 78 dBA

Connection capacities

6mm² cable clamp type

When a bell transformer is installed in an enclosure with main voltage equipment, 230V cable should be used on the secondary side of the transformer or extra low voltage cable should be sheathed within the enclosure.

Note : the transformers have a higher no load voltage. The stated voltages correspond to the voltages on nominal load.

Safety transformers

- 230V 12-24 V AC, 50/60 Hz

Description	Width in module 17.5 mm	Pack qty	Cat. ref.
16 VA	4	1	ST313
25 VA	4	1	ST312
40 VA	4	1	ST314
63 VA	6	2	ST315



ST313



Bell transformers

- 230V 8-24 V AC, 50/60 Hz

Description	Width in module 17.5 mm	Pack qty	Cat. ref.
4 VA, 8 V / 0.5V, 12 V / 0.33 A	2	6	ST301
8 VA, 8 V / 1 A, 12 V / 0.67 A	2	6	ST303
16 VA, 8 V / 2 A, 12 V / 1.33 A	3	1	ST305



ST303

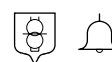

Bells

Description	Width in module 17.5 mm	Pack qty	Cat. ref.
8/12 V AC, 5 VA - 0.33 A	1	12	SU212
230 V AC, 6.5 VA - 0.03 A	1	12	SU213



SU212



Buzzers

Description	Width in module 17.5 mm	Pack qty	Cat. ref.
8/12 V AC, 4 VA - 0.35 A	1	12	SU214
230 V AC, 6.5 VA - 0.03 A	1	12	SU215



SU214





SN316

Sockets 10/16 A - 230 V AC

- with safety shutters

Description	Symbol	Width in module 17.5 mm	Pack qty	Cat. ref.
2P + E		2.5	4	SN216
2P + E with light indicator		2.5	4	SN316
2P + E, German standard 10/16 A, Italian standard 10 A		2.5	4	SN010



SN220

Sockets 20 A - 400 V AC

- with safety shutters

Description	Symbol	Width in module 17.5 mm	Pack qty	Cat. ref.
2P + E		4	3	SN120
3P + E		4	4	SN220
3P + E + N		4	4	SN320

Reference principle



EW serie contactors

Rated current AC-3

005 = 7A minicontactor	063 = 63A
006 = 9A minicontactor	070 = 72A
007 = 7A	100 = 105A
009 = 9A	120 = 115A
012 = 12A	150 = 147A
016 = 16A	180 = 179A
020 = 22A	220 = 225A
025 = 26A	300 = 300A
032 = 32A	400 = 400A
038 = 38A	500 = 500A
040 = 40A	630 = 630A
050 = 55A	

Rated control supply voltage Us

C = 220V AC 50/60Hz	K = 240V AC 50Hz
D = 380V AC 50/60Hz	L = 400V AC 50Hz
E = 24V DC	M = 415V AC 50Hz
F = 48V DC	N = 24V AC 50/60Hz
H = 110V AC 50/60Hz	P = 48V AC 50/60Hz
J = 230V AC 50Hz	Q = 127V AC 50/60Hz

Thermal overload relays

EWT...B

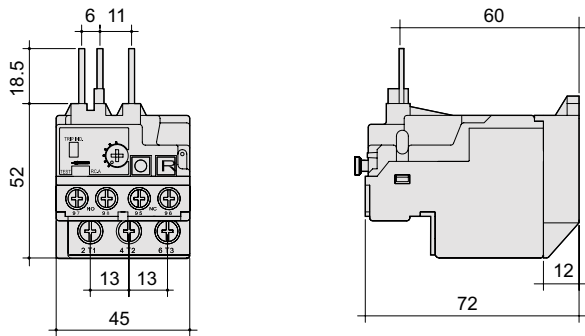

EWT...C

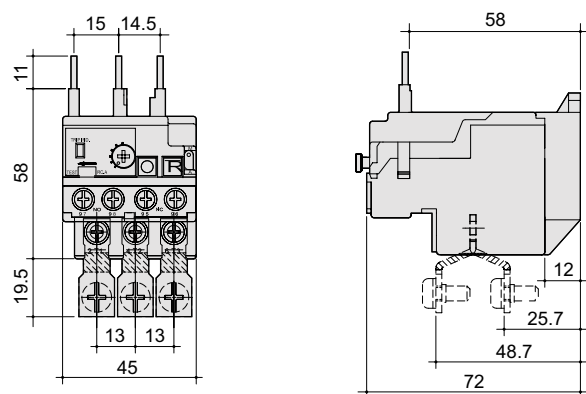

Extension terminal applicable for thermal relay above 36A.

EWT...D

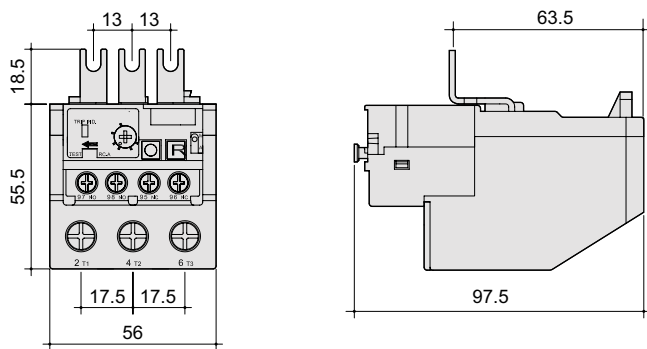

EWT...E

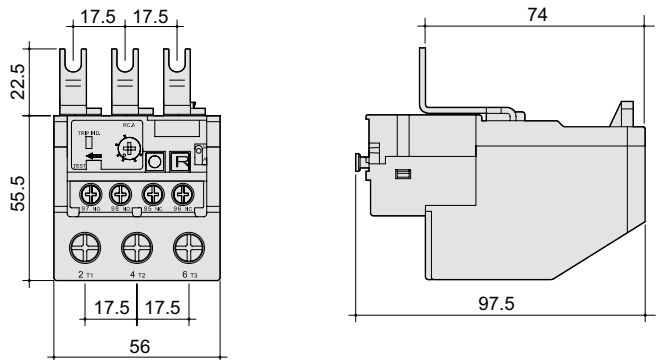

EWT...G

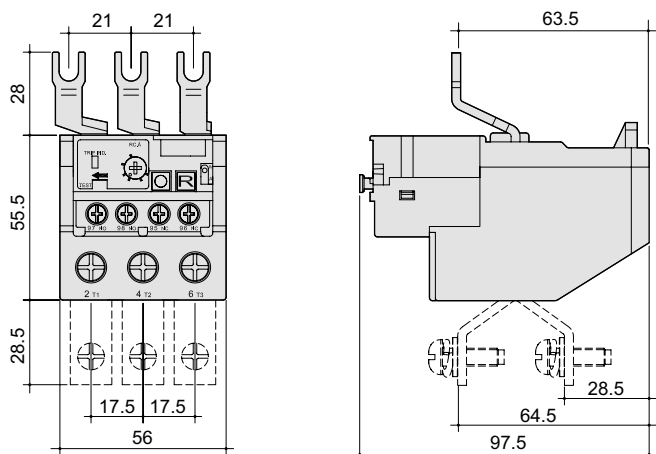

EWT...H

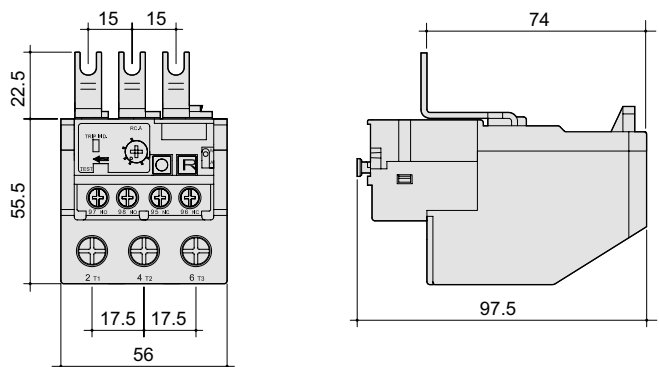

Extension terminal applicable for thermal relay above 50A.

Separated thermal overload relays

EWT...F

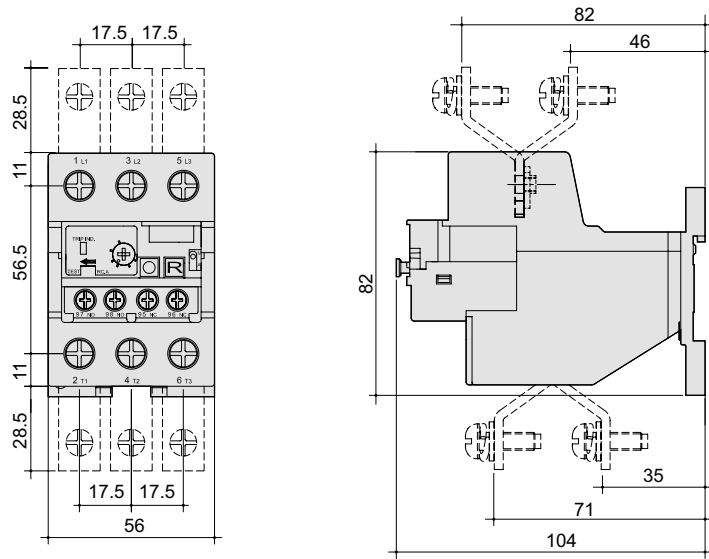

Extension terminal for wire connection.

Description		Modular contactor and relay						Auxiliary contact
Standard conformity		EN 61095						
Approvals		NF - VDE - IMQ - KEMA - RMC / CCC						
		Contactor		Contactor		Contactor		Accessory
Number of modules		1		2		3		1/2
Thermal current I _{th} (40°C)		16A	25A	16A	25A	40A	63A	6A
Rated frequency		50Hz	50Hz	50Hz	50Hz	50Hz	50Hz	50Hz
Rated insulation voltage (Ui)		250V	250V	440V	440V	440V	440V	250V
Rated impulse withstand voltage (Uimp)		4kV	4kV	4kV	4kV	4kV	4kV	4kV
Protection degree		2	2	2	2	2	2	2
Rated operating currents and power ratings in AC								
AC-1 / AC-7a	rated operational currents Ie	16A	25A	16A	25A	40A	63A	-
	rated operational power	3kW	4.6kW	3kW	4.6kW	7.3kW	11.6kW	-
AC-3 / AC-7b	rated operational currents Ie	5.5A	8.5A	5.5A	8.5A	25A	32A	-
	rated operational power	570W	880W	570W	880W	2.6kW	3.3kW	-
AC-12	rated operational currents at 230V	-	-	-	-	-	-	6A
AC-15	rated operational currents at 230V	-	-	-	-	-	-	2A
Mechanical and electrical endurences								
Mechanical endurance	nr of operations	1,000,000	1,000,000	1,000,000	1,000,000	1,000,000	1,000,000	1,000,000
Electrical endurance at Ie AC7a (AC12 for aux contacts)	nr of operations	60,000	60,000	60,000	60,000	60,000	60,000	60,000
MCB protected short-circuit withstand								
Prospected short-circuit current	rms	1kA	3kA	1kA	3kA	3kA	3kA	1kA
Associated protection		MCB C16-6kA	MCB C25-6kA	MCB C16-6kA	MCB C25-6kA	MCB C40-10kA	MCB C63-10kA	6A 10x38 gG fuse or MCB
Power dissipation								
Power dissipation per current path		1W	1.5W	1W	1.5W	3.2W	5W	0.4W
Magnetic system for standard and low noise contactors								
Pick-up		7.4VA	7.4VA	9.2VA	9.2VA	60VA	60VA	-
Coil consumption		1.8VA	1.8VA	1.85VA	1.85VA	7VA	7VA	-
Closing delay		25ms	25ms	25ms	25ms	25ms	25ms	-
Opening delay		15ms	15ms	15ms	15ms	20ms	20ms	-
Connection								
Main contact cable section	rigid	1...10mm ²	1...10mm ²	1...10mm ²	1...10mm ²	4...25mm ²	4...25mm ²	1...6mm ²
	flexible	1...6mm ²	1...6mm ²	1...6mm ²	1...6mm ²	4...16mm ²	4...16mm ²	1...6mm ²
Main contact connection screw	type	M3.4	M3.4	M3.4	M3.4	M3.4	M3.4	M3.4
	posidrive	PZ2	PZ2	PZ2	PZ2	PZ2	PZ2	PZ2
	max. tight. torque	1.2Nm	1.2Nm	1.2Nm	1.2Nm	2Nm	2Nm	1.2Nm
Coil connection cable section	rigid	1...10mm ²	1...10mm ²	1...10mm ²	1...10mm ²	1...10mm ²	1...10mm ²	1...10mm ²
	flexible	1...6mm ²	1...6mm ²	1...6mm ²	1...6mm ²	1...6mm ²	1...6mm ²	1...6mm ²
Coil connection screw	type	M3.4	M3.4	M3.4	M3.4	M3.4	M3.4	M3.4
	posidrive	PZ2	PZ2	PZ2	PZ2	PZ2	PZ2	PZ2
	max. tight. torque	1.2Nm	1.2Nm	1.2Nm	1.2Nm	1.5Nm	1.5Nm	-
Working temperature								
		-10°C to +50°C						
Storage temperature								
		-40°C to +80°C						

Choice of contactors

The choice of contactor is based on many factors:

- type of the load supplied,
- nominal current of the load,
- operating voltage,
- number of operations,
- etc..

The contactors are AC7-a (resistive load) and AC7-b (inductive load) approved.

Heating applications

The choice of the contactor is based on the electrical heating load, and the targeted life time.

Single phase

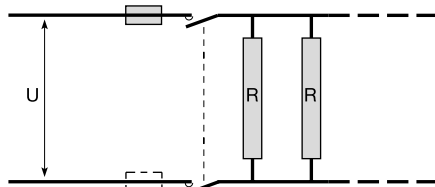

Three phase supply

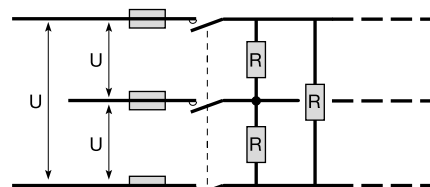

Number of operations		60,000	100,000	150,000	300,000	600,000	
Maximum load* in kW	230V	16A	3.0	2.5	1.9	0.8	0.7
		25A	4.6	4.0	3.0	1.3	1.0
		40A	7.3	6.3	4.7	2.2	1.6
		63A	11.6	10.0	7.5	3.5	2.5
	400V	16A	8.9	8.0	5.8	2.8	2.0
		25A	13.8	12.0	8.6	4.3	3.0
		40A	22.0	18.5	14.3	6.3	5.0
		63A	35.0	30.0	22.6	10.2	7.6

* On three phase configuration the maximum load per phase corresponds to the values states divided by 3.

Example:

Function of a heating installation 200 days/annum, 75 operations per day (1 opening + 1 closing = 2 operations)
Mechanical life = 10 years
Total number of operations: 200 x 75 x 10 = 150,000
in that case, depending on the type of circuit, select a contactor 40A 230V to control a load of 4.7 kW, or a contactor 16A 400V to control a load up to 5.8 kW.

**Motor applications (AC7-b equivalent to AC3)
Single phase 230V**

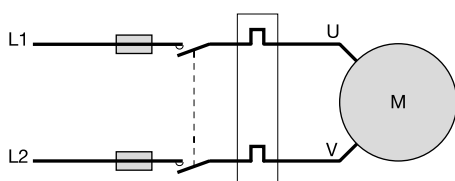

Three phase 400V

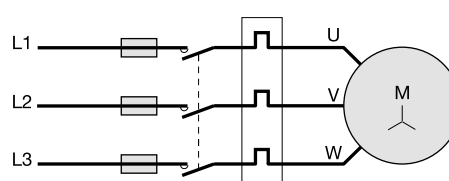

	Contactor rating	Control diagram	
		2P 230V single phase	3P 400V three phase
Maximum power for the motor	16A	0.57 kW	1.7 kW
	25A	0.88 kW	2.65 kW
	40A	2.6 kW	7.8 kW
	63A	3.3 kW	10 kW

Influence of working temperature:

Derating factor between 40°C and 50°C: 0.9

Example: heating with convactor.

The maximum load of ESC225 is 4.6kW for 60,000 operations and for a temperature <40°C.

Between 40°C and 50°C, the load is 4.6 x 0.9 i.e. 4.14kW

Adjacent fitting:

It is necessary to put a heat dissipation insert (reference LZ060) between each 3 products, or each humfree contact.

Selection chart for lighting loads

Lighting systems with electronic ballasts cause inrush current peaks. Therefore we recommend you use the chart below to determinate the maximum amount of lamps that can be connected to a Hager contactor: the chart gives the maximum amount of lamps per contact.

In 2014 the performances of the contactors in combination with lights increased. The products identified on the front face with this pictogramm (+) can accept a higher number of lamps. For these products, see the figures in the column with the pictogram in the header.

Lighting technology	Power of the lamp	Contactor 16A	Contactor 25A	Contactor 16A (+)	Contactor 25A (+)	Contactor 40A	Contactor 63A	
Compact fluo lamps								
Compact fluo lamp with external electronic ballast	5W	11	15	17	27	49	76	
	7W	11	15	17	27	49	76	
	9W	9	13	16	26	40	63	
	11W	9	13	16	26	40	63	
	15W	7	11	14	22	36	57	
	18W	7	11	14	22	36	57	
	20W	7	11	14	22	36	57	
	23W	7	11	14	22	36	57	
	26W	7	11	14	22	36	57	
	Compact fluo lamp with integrated electronic ballast	5W	17	27	34	54	86	135
7W		17	27	34	54	86	135	
9W		17	27	34	54	86	135	
11W		17	27	34	54	86	135	
15W		17	27	34	54	86	135	
18W		13	20	25	40	63	100	
20W		13	20	25	40	63	100	
23W		13	20	25	40	63	100	
26W		13	20	25	40	63	100	
Incandescent lamps								
Tungsten & halogen lamps 230V	40W	32	50	36	57	76	120	
	60W	21	33	28	45	67	105	
	75W	17	27	24	38	63	100	
	100W	13	20	17	28	41	65	
	150W	8	13	11	18	29	45	
	200W	6	9	8	14	22	35	
	300W	4	7	6	10	15	23	
	500W	2	3	3	6	9	14	
	1000W	0	0	1	2	4	7	
	Tungsten & halogen lamps 12 or 24V	20W	13	20	25	40	139	218
35W		8	13	16	26	82	129	
50W		6	9	11	18	60	94	
75W		4	6	7	12	52	82	
100W		2	3	3	6	35	55	
150W		1	2	2	4	20	31	
LED								
LED 230V with integrated electronic ballast - non dimmable	4W	17	27	34	54	86	135	
	4.5W	17	27	34	54	86	135	
	6W	17	27	34	54	86	135	
	7W	17	27	34	54	86	135	
	8W	17	27	34	54	86	135	
	12W	17	27	34	54	86	135	
	17W	13	20	25	40	63	101	
	18W	13	20	25	40	63	101	
	22W	13	20	25	40	63	101	
	30W	9	14	17	28	44	70	
	34W	9	14	17	28	44	70	
	40W	9	14	17	28	44	70	
	50W	7	11	14	22	35	55	
	LED 230V with integrated electronic ballast - dimmable	4W	38	60	76	120	159	250
		4.5W	38	60	76	120	159	250
6W		38	60	76	120	159	250	
7W		38	60	76	120	159	250	
8W		38	60	76	120	159	250	
12W		38	60	76	120	159	250	
17W		28	44	56	88	118	185	
18W		28	44	56	88	118	185	
22W		28	44	56	88	118	185	
30W		20	31	39	62	82	130	
34W		20	31	39	62	82	130	
40W		20	31	39	62	82	130	
50W		16	24	30	48	65	102	
LED 230V headlight with integrated electronic ballast		100W			3	5	6	9
		150W			1	3	4	6
	200W			1	2	4	6	
LED 12V with separated transformer - dimmable	1W	38	60	76	120	180	220	
	2.5W	38	60	76	120	180	220	
	4W	38	60	76	120	180	220	
	5W	38	60	76	120	180	220	
	7W	38	60	76	120	160	200	
	10W	38	60	76	120	160	200	
	15W	28	44	56	88	160	200	
	Fluorescent tubes							
T5 single - uncompensated	15W	13	20	19	30	70	100	
	18W	13	1220	1919	1930	70	100	
	20W	12	15	17	30	70	100	
	36W	10	13	16	28	60	90	
	40W	9	12	15	26	60	90	
	42W	7	9	10	24	55	83	
	58W	6	8	10	17	35	56	
	65W	5	7	9	17	35	56	
	80W	4	5	6	15	30	48	
	115W	3	5	6	10	20	32	
	140W				10	16	26	

Lighting technology	Power of the lamp	Contacteur 16A	Contacteur 25A	Contacteur 16A (+)	Contacteur 25A (+)	Contacteur 40A	Contacteur 63A	
T5 single - parallel compensation	15W	7	11	12	20	36	57	
	18W	7	11	12	20	36	57	
	20W	7	11	12	20	36	57	
	36W	7	11	12	20	34	53	
	40W	7	11	12	20	29	45	
	42W	7	11	12	20	29	45	
	58W	6	10	9	15	27	42	
	65W	6	10	9	15	27	42	
	80W	6	10	9	15	27	42	
	115W	6	10	9	15	25	39	
	T5 double - uncompensated	2 x 18W	13	20	25	40	50	78
2 x 20W		12	19	24	38	50	78	
2 x 36W		12	15	19	30	44	69	
2 x 40W		10	13	16	26	40	63	
2 x 42W		9	12	15	24	40	63	
2 x 58W		7	9	11	18	27	42	
2 x 65W		6	8	10	16	27	42	
2 x 80W		5	7	8	14	22	35	
2 x 115W		4	5	6	10	16	25	
T5 double - serie compensation		2 x 18W	7	11	14	22	34	53
	2 x 20W	7	11	14	22	29	45	
	2 x 36W	6	10	12	20	27	42	
	2 x 40W	6	10	12	20	27	42	
	2 x 42W	6	10	12	20	27	42	
	2 x 58W	6	10	12	20	25	39	
	2 x 65W	5	7	8	14	23	36	
	2 x 80W	5	7	8	14	20	31	
	2 x 115W	4	5	6	10	17	25	
	T5 single - electronic ballast	15W	7	11	14	22	36	57
18W		7	11	14	22	36	57	
20W		7	11	14	22	36	57	
36W		7	11	14	22	34	53	
40W		7	11	14	22	29	45	
42W		7	11	14	22	29	45	
58W		6	10	12	20	27	42	
65W		6	10	12	20	27	42	
80W		6	10	12	20	27	42	
115W		6	10	12	20	25	39	
T5 double - electronic ballast		2 x 18W	7	11	14	22	34	53
	2 x 20W	7	11	14	22	29	45	
	2 x 36W	6	10	12	20	27	42	
	2 x 40W	6	10	12	20	27	42	
	2 x 42W	6	10	12	20	27	42	
	2 x 58W	6	10	12	20	25	39	
	2 x 65W	5	7	8	14	23	36	
	2 x 80W	5	7	8	14	20	31	
	2 x 115W	4	5	6	10	17	25	
	Discharge lamps							
High-pressure mercury-vapor lamps - without compensation	50W	9	14	17	28	32	50	
	80W	6	9	11	18	24	37	
	125W	3	5	6	10	18	28	
	250W	2	3	3	6	10	15	
	400W	1	1	1	2	6	9	
	700W	0	0	0	0	4	5	
High-pressure mercury-vapor lamps - parallell compensation	50W	7	11	14	22	26	40	
	80W	5	8	10	16	22	34	
	125W	3	5	6	10	15	23	
	250W	2	3	3	6	9	14	
	400W	1	1	1	2	5	8	
	700W	0	0	0	0	3	5	
	1000W	0	0	0	0	2	3	
Low pressure sodium lamps - without compensation	18W	8	10	8	12	17	23	
	35W	4	6	7	9	14	20	
	55W	3	6	7	9	14	20	
	90W	2	4	5	6	9	14	
	135W	1	3	3	4	6	8	
	180W	1	2	2	4	6	8	
	Low pressure sodium lamps - parallel compensation	18W	5	7	5	8	12	24
35W		4	6	4	7	10	23	
55W		3	5	3	5	10	19	
90W		2	3	3	4	8	16	
135W		1	2	1	2	5	7	
180W		1	2	1	2	5	6	
High pressure sodium lamps - without compensation		35W	11	14	15	24	30	50
	50W	9	12	10	15	22	34	
	70W	8	9	8	12	18	28	
	110W	6	8	6	10	14	22	
	150W	4	7	5	8	10	16	
	250W	2	4	3	5	6	10	
	400W	0	1	1	2	4	6	
	1000W	0	1	1	1	2	3	
	High pressure sodium-vapour lamps - electronic ballast or parallel compensation	35W	6	9	11	18	31	50
		50W	6	9	11	18	22	35
70W		4	6	7	12	16	25	
110W		3	5	6	8	13	21	
150W		3	5	4	6	8	13	
250W		2	3	3	4	7	11	
400W		1	1	1	2	5	8	
1000W		0	0	0	1	2	3	
Metal halide lamps - without compensation	35W	12	24	19	30	42	55	
	70W	10	15	12	17	26	36	
	150W	6	7	8	12	14	20	
	250W	3	5	5	8	9	14	
	400W	1	2	2	4	6	9	
	1000W	0	0	0	0	3	5	
	Metal halide lamps - electronic ballast or parallel compensation	35W	6	10	12	18	22	12
70W		5	8	10	13	22	10	
150W		3	5	6	8	12	6	
250W		3	5	6	7	9	3	
400W		1	1	1	2	5	1	
1000W		0	0	0	1	2	0	

Technical specifications

	EZN001 - EZN002 - EZN003 - EZN004 - EZN005 - EZN006
Electrical characteristics	
Supply voltage	12 - 230 V AC (±10%), 50Hz/60Hz 12 - 48 V DC (±10%)
Output	1 volt free C/O contact
Life expectancy	
max load AC1	8 A / 230 V AC 50 000 cycles
incandescent	450 W AC 50 000 cycles
fluorescent non comp.	600 W AC 50 000 cycles
inductive load 0.6pf	5 A AC 100 000 cycles
Min power	
AC	100 mA at 230 V
DC	100 mA at 12 V
Galvanic isolation	2 kV
Standard / norm	EN60669-2-1
Functional characteristics	
Timer range	0.1 s. - 10 h
Min. command period	
AC	50 ms
DC	30 ms
Operating temperature	
working	-10°C to +50°C
storage	-40°C to +50°C
Connection capacity	
flexible	1 - 6 mm ²
rigid	1.5 - 10 mm ²

Wiring diagrams

EZN001, EZN003, EZN005, EZN006 (functions D,E,F)

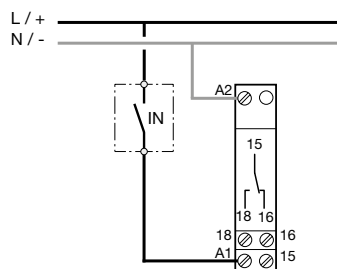

EZN002, EZN004, EZN006 (functions A,B,C)

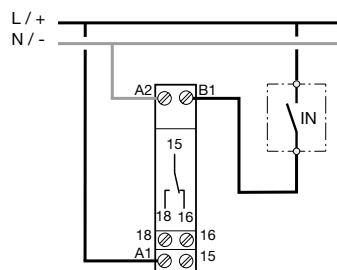

Delay timers

Delay timer devices are used to control a variety of processes where the requirement is for switching circuits on, off or delaying the on or off switching for a pre-set period of time. Typical device types are:

- delay on: intended to delay the starting or switching of a circuit for a set period of time following the command signal e.g. to delay the starting of motor loads where a large number of motors are to be started by the same switch to reduce the effects of the starting currents.
- delay off: intended to delay the stopping or switching off of a circuit for a set period of time following the removal of the command signal e.g. to overrun an extractor following the switching off of a process that creates fumes.
- Adjustable time on: intended to switch on for a set period, the command must remain on throughout the set period e.g. to switch on two sets of heaters with one set (the boost) switching off after the set period.
- Impulse timer: intended to switch on for a set period, the command signal length is not important e.g. to boost a time clock controlled circuit such as a water storage heater.
- Symmetrical timer: intended to toggle a circuit on and off in regular time patterns e.g. to run an extractor intermittently.

Multifunction timer - 8 individual functions

- A = timer.
 - B = delay off (output relay opens either at end of command or after set time period - whichever is shorter).
 - C = delay off.
 - D = delay on.
 - E = delay on (output relay closes either at end of command or after set time period - whichever is shorter).
 - F = Symmetrical timer.
- On selection - contact permanently closed
Off selection - contact permanently open

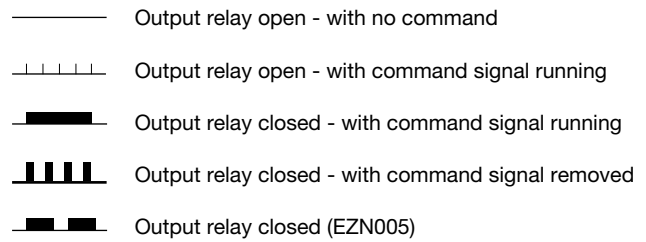

**Delay on
EZN001 and EZN006 function D**

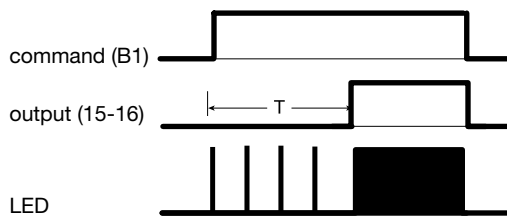

**Impulse timer
EZN004 and EZN006 function A**

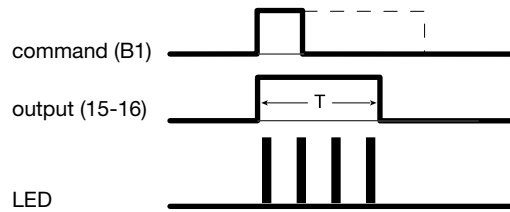

**Delay off
EZN002 and EZN006 function C**

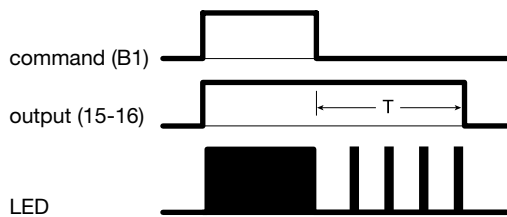

**Symmetrical flasher
EZN005 and EZN006 function F**

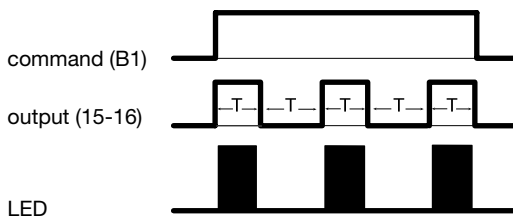

**Adjustable time on
EZN003 and EZN006 function E**

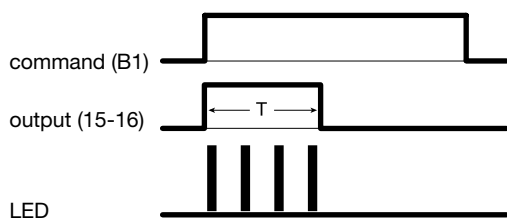

**Multifunction timer
EZN006 function B**

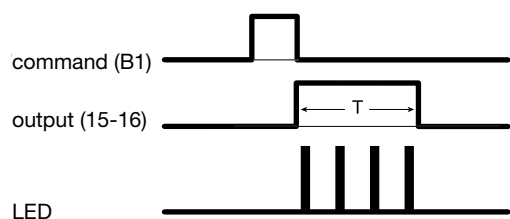

References	EN146	EN145
width	1 ■	1 ■
Coil control circuit		
control circuit voltage	230V	10 to 26V
frequency	50Hz	50/60Hz and DC
connection - rigid (mm ²) - flexible (mm ²)	1 to 6 0.5 to 4	1 to 6 0.5 to 4
pick-up coil consumption	5VA	(a)
coil consumption	5VA	(a)
Power circuit		
current (AC1, AC7a)	5A	5A
insulation voltage	250V	250V
rated frequency	50/60Hz	50/60Hz
current (AC3, AC7b)	-	-
connection - rigid (mm ²) - flexible (mm ²)	1 to 6 0.5 to 4	1 to 6 0.5 to 4
mechanical endurance	-	-
electrical endurance	200 000 cycles	-
Working temperature	-10°C to +50°C	
Storage temperature	-40°C to +80°C	

(a): consumption of EN145

control voltage	consumption
12 V DC	0.5 W
24 V DC	1.5 W
12 V AC	1 VA
24 V AC	2 VA

Technical characteristics

	EPN510 EPN515 EPN520	EPN516	EPN501 EPN503 EPN526	EPN513 EPN518 EPN524	EPN511 EPN519 EPN521	EPN525 EPN540 EPN546	EPN548	EPN528 EPN541
Coil in AC								
voltage rating	230V	110V	48V	24V	12V	230V	48V	24V
tolerance	+10/-20%							
frequency	50/60Hz							
start consumption	25VA					55VA		
Coil in DC								
voltage rating	110V	48V	24V	12V	-	110V	24V	12V
tolerance	+10/-20%							
start consumption	12VA				-		25W	
Contacts								
max. perm. Current AC1	16A							
voltage	250V AC						400V AC	
electrical endurance	150 000 operations							
mechanical endurance	500 000 operations							
ohmic loss per current path	1,2W							
minimum duration of impulse	50 ms							
maximum time under voltage	1 H							
push button with signal lamp without condensator	6 (1mA / lamp)							
push button with signal lamp with condensator = 1uF parrallel *	10 (1mA / lamp)							
push button with signal lamp with condensator = 2.2uF parrallel *	44 (1mA / lamp)							
ingress protection	IP20							
working temperature	-5 to +40°C							
storage temperature	-40 to +80°C							
Connection								
flexible	6mm ²							
rigid	10mm ²							

Power, control
and signaling

Auxiliaries + latching relays, possible combinations:

EPN050: auxiliary for centralised control

EPN051: auxiliary contact

EPN052: auxiliary for multi levelled centralised control

EPN053: auxiliary for control by maintained contact

...with 1 auxiliary

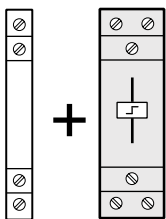

EPN050 + 24 to 230V AC

EPN051 + 12 to 230V AC
12 to 110V DC

EPN053 + 24 to 230V AC

...with 2 auxiliaries

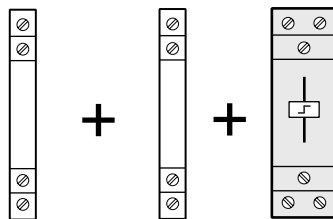

EPN051 + EPN050 + 24 to 230V AC

EPN052 + EPN050 + 24 to 230V AC

EPN051 + EPN053 + 24 to 230V AC

EPN051 + EPN051 + 12 to 230V AC
12 to 110V DC

...with 3 auxiliaries

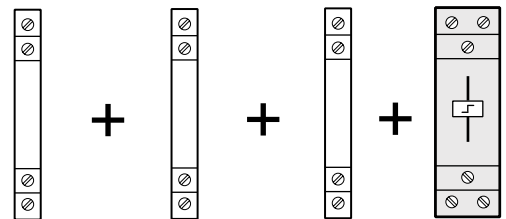

EPN052 + EPN051 + EPN050 + 24 to 230V AC

Technical characteristics

The following table shows the number of lamps which can be connected per phase at 230V 50Hz.

Incandescent lamps									
230V lamps with and without halogen									
load:	40W	60W	75W	100W	150W	200W	300W	500W	1000W
number:	45	30	24	18	12	9	5	3	2
Low voltage halogen									
load:	20W	50W	75W	100W	150W	300W			
number:	70	28	19	14	9	3			
Fluorescent lamps uncompensated									
load:	15W	18W	30W	36W	58W				
number:	29	25	25	24	14				
Parallel compensation									
load:	15W	18W	30W	36W	58W				
number:	27	27	25	25	16				
C total max _(a) :	121μF	121μF	112μF	112μF	72μF				
Two lamp circuit, series compensation									
load:	2x18W	2x20W	2x36W	2x40W	2x58W	2x65W			
number:	40	40	22	22	12	12			
C :	2.7μF	2.7μF	3.4μF	3.4μF	5.3μF	5.3μF			
load:	18W	36W	58W						
number:	30	28	15						
Two lamp circuit with electronics power supply units									
load:	2x18W	2x36W	2x58W						
number:	15	13	8						
Flo compact uncompensated									
load:	7W	10W	18W	26W					
number:	50	45	40	25					
Flo compact electronic power supply unit									
load:	11W	15W	20W	23W					
number:	80	60	50	40					
High intensity discharge metal halogen lamps, uncompensated									
load:	50W	80W	125W	250W	400W				
number:	11	9	7	3	2				
Metal halogen lamps, parallel compensation									
load:	50W	80W	125W	250W	400W				
number:	9	8	6	3	2				
C total max _(a) :	63μF	58μF	60μF	54μF	50μF				
High pressure sodium vapour lamps, uncompensated									
load:	70W	150W	250W	400W					
number:	9	5	3	2					
High pressure sodium vapour lamps, parallel compensated									
load:	70W	150W	250W	400W					
number:	5	3	2	1					
C total max _(a) :	60μF	54μF	64μF	50μF					

(a) : these values must not be exceeded

Auxiliaries for latching relays

	EPN050	EPN051	EPN052	EPN053
voltage rating	(a)	-	(a)	(a)
	24 to 230V AC			
	12 to 110V DC			
nominal load	-	2A/250V AC	-	-
I _{min} /230V AC	-	15mA	-	-
working temperature	-5 to +40°C			
storage temperature	-40 to 80°C			
Connections : flexible	6 mm ²			
rigid	10 mm ²			

(a) : according to a latching relay connected with an auxiliary

Installation of the auxiliaries

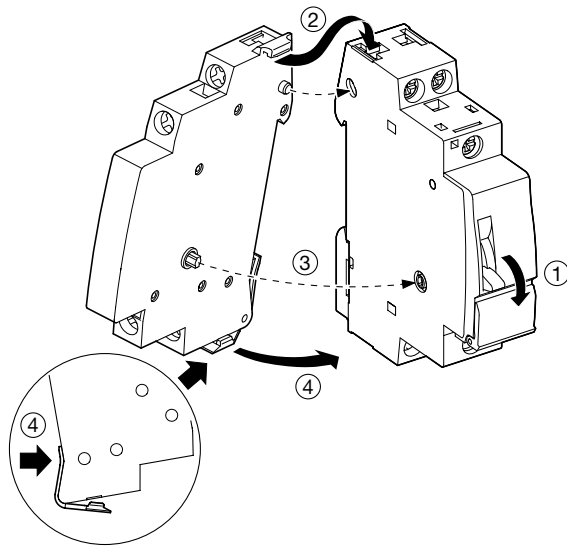

Application diagram

centralised command (EPN050 - EPN052)

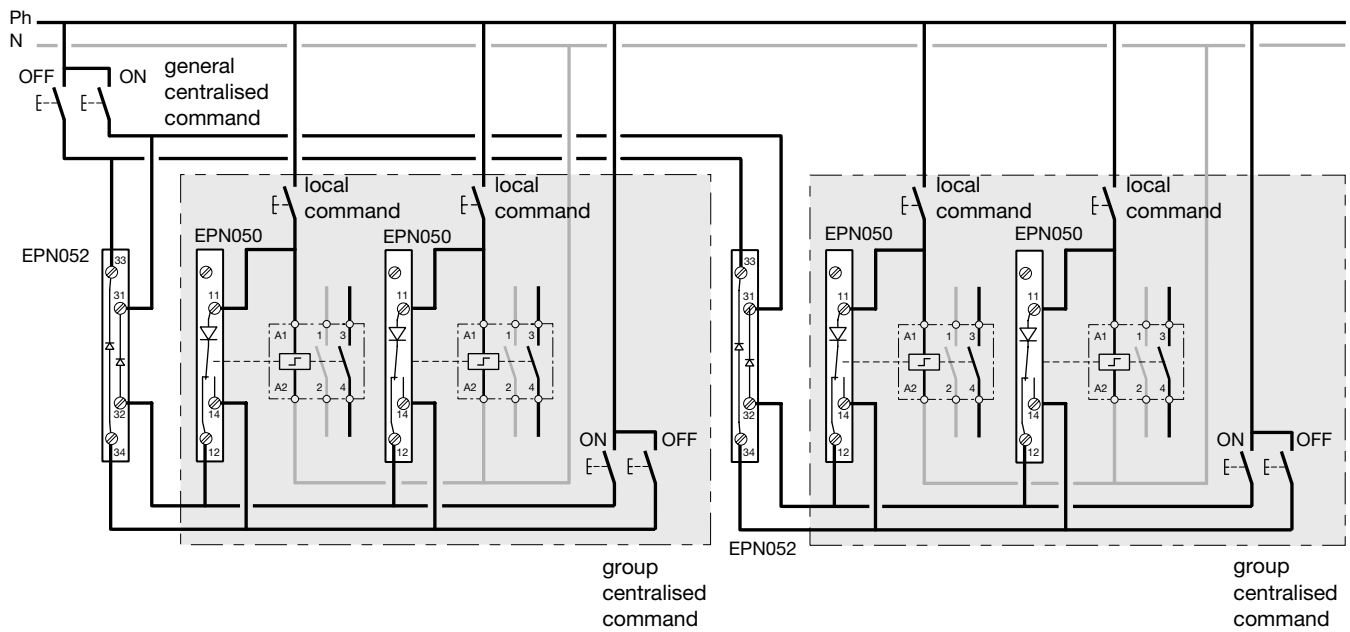

Power, control and signaling

Remote signalling (EPN051)

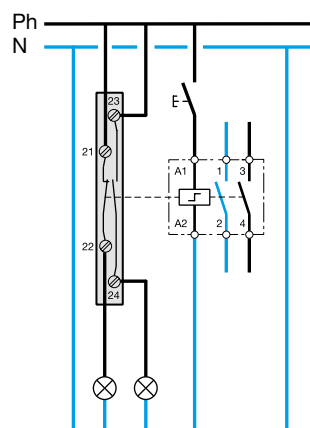

Maintained command (EPN053)

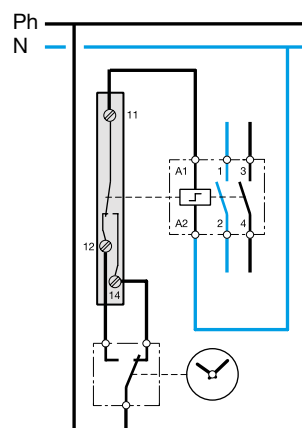

Technical characteristics

references	SBN SBB SFH SFT SFM	SBN SBB	SBN SBB
number of pole	1P - 2P - 3P - 4P		
frame size	frame size 1	frame size 2	frame size 3
comply with standard	IEC 60947-3	ok	ok
	IEC 60669-2-4	ok	-
thermal current I _{th} (40°C)	16A 25A 32A	32A 40A 63A	63A 80A 100A 125A
operational frequency	50/60 Hz	50/60 Hz	50/60 Hz
rated insulation voltage (U _i)	440V	440V	440V
rated impulse withstand voltage U _{imp}	4kV	6 kV	6 kV
protection degree	3 (SB) / 2 (SF)	3	3
working temperature	-20 to 50°C		
storage temperature	-40 to 80°C		

Operational current I_e

rated voltage	load duty category	16A	25A	32A	32A	40A	63A	63A	80A	100A	125A
400V AC	AC 21-A ⁽¹⁾	16A	25A	32A	32A	40A	63A	63A	80A	100A	125A
	AC 22-A ⁽¹⁾	16A	25A	32A	32A	40A	63A	63A	80A	100A	125A

Short circuit characteristics

rated short time withstand current 1s I _{cw} (rms)	IEC 60947-3	240A	375A	480A	480A	600A	945A	945A	960A	1200A	1500A
prospective short circuit current (rms)	EN 60669-2-4	3kA			6kA			n/a			

Mechanical characteristics

rigid cable section	16 mm ²	25 mm ²	50 mm ²
flexible cable section	10 mm ²	16 mm ²	35 mm ²
tightening torque	1.8 Nm	2.8 Nm	3.6 Nm
busbar thickness	n/a	1 to 1.5 mm	1.5 to 2 mm
IP protection degree	20		
mechanical endurance (number of cycles)	100000	30000	20000
electrical endurance @ AC22 (number of cycles)	25000	5000	2500

Overall dimension

width (mm)	1P	17.5	
	2P	17.5	36
	3P	36	53
	4P	36	72
height (mm)	1-4P	83	
depth (mm)	1-4P	72	

⁽¹⁾ A category: frequent operation

Important: The switch should also be protected against overloads.
The switch calibration needs to be at least equal to the calibration of the upstream MCB.

Cat. ref.	In/A	Un/V 50/60Hz	Nr of poles	mechanical endurance in nr of operations	mechanical endurance in nr of operations In-Un Cosφ=0,6	Short circuit withstand (kA presumed) - Upstream protection														
						Fuse links										MCB				
						gG fuse (A)										MV, MW -3kA (EN 60898-1) (A)				
	16A	25A	32A	40A	63A	80A	100A	125A	16A	20A	25A	32A	40A							
SBN SBB	16	230/400V	1,2,3,4	300 000	30 000	10										3				
	25	230/400V	1,2,3,4	300 000	30 000	10	10									3	3	3		
	32	230/400V	1,2,3,4	300 000	30 000	10	10	10								3	3	3	3	
	40	230/400V	1,2,3,4	150 000	30 000	10	10	10	10							3	3	3	3	3
	63	230/400V	1,2,3,4	150 000	10 000	10	10	10	10	10						3	3	3	3	3
	80	400V	1,2,3,4	90 000	7 500	10	10	10	10	10	10	6				3	3	3	3	3
	100	400V	1,2,3,4	90 000	7 500	10	10	10	10	10	10	6				3	3	3	3	3
	125	400V	1,2,3,4	40 000	2 000	10	10	10	10	10	10	6	3			3	3	3	3	3



Product type	In/A	Un/V 50/60Hz	Nr of poles	mechanical endurance in nr of operations	mechanical endurance in nr of operations In-Un Cosφ=0,6	Short circuit withstand (kA presumed) - Upstream protection														
						MCB										HLF - 10kA HMB, HMC-15kA (IEC 60947-2) (A)				
						MBN, MCN - 6kA (EN 60898-1) MB, MT, MC, MU - 6kA (EN 60898-1) (A)					NBN, NCN - 10 kA (IEC 60947-2) NRN - 15 to 25 kA (IEC 60947-2) (A)									
	16A	25A	32A	40A	63A	80A	100A	125A	16A	20A	25A	32A	40A	50A	63A	60A	80A	125A		
SBN SBB	16	230/400V	1,2,3,4	300 000	30 000	3														
	25	230/400V	1,2,3,4	300 000	30 000	3	3	3												
	32	230/400V	1,2,3,4	300 000	30 000	3	3	3	3											
	40	230/400V	1,2,3,4	150 000	30 000	6	6	6	6	6										
	63	230/400V	1,2,3,4	150 000	10 000	6	6	6	6	6	6									
	80	400V	1,2,3,4	90 000	7 500	6	6	6	6	6	6									
	100	400V	1,2,3,4	90 000	7 500	6	6	6	6	6	6									
	125	400V	1,2,3,4	40 000	2 000	6	6	6	6	6	6	6	6	6	6	6	6	6	6	

Product type	In/A	Un/V 50/60Hz	Im trip-free switches	Short circuit withstand (kA presumed) - Upstream protection														
				Fuse links										MCB				
				gG fuse (A)										MV, MW -3kA (EN 60898-1) (A)				
	16A	25A	32A	40A	63A	80A	100A	16A	20A	25A	32A	40A						
SA2xx	40	230V	1500 A	80	80	80	80						3	3	3	3	3	
	63	230V	1500 A	80	80	80	80	32					3	3	3	3	3	
	80	230V	1500 A	80	80	80	80	32	10				3	3	3	3	3	
SA4xx	40	400V	1500 A	80	80	80	80						3	3	3	3	3	
	63	400V	1500 A	80	80	80	80	32					3	3	3	3	3	
	80	400V	1500 A	80	80	80	80	32	10				3	3	3	3	3	

Product type	In/A	Un/V 50/60Hz	Im trip-free switches	Short circuit withstand (kA presumed) - Upstream protection														
				MCB										HLF - 10kA HMB, HMC-15kA (IEC 60947-2) (A)				
				MBN, MCN - 6kA (EN 60898-1) MB, MT, MC, MU - 6kA (EN 60898-1) (A)					NBN, NCN - 10 kA (IEC 60947-2) NRN - 15 to 25 kA (IEC 60947-2) (A)									
	16A	25A	32A	40A	63A	80A	100A	16A	20A	25A	32A	40A	50A	63A	80A	100A		
SA2xx	16	230V	1500 A	6	6	6	6	6					10	10	10	10		
	25	230V	1500 A	6	6	6	6	6	6	6			10	10	10	10	10	
	32	230V	1500 A	6	6	6	6	6	6	6			10	10	10	10	15	
SA4xx	40	400V	1500 A	6	6	6	6	6					10	10	10	10		
	63	400V	1500 A	6	6	6	6	6	6	6			10	10	10	10	10	
	80	400V	1500 A	6	6	6	6	6	6	6			10	10	10	10	10	

Discrimination chart (withstand)			Short circuit withstand (kA presumed) - upstream protection												
			Fuse links								MCB				
product type	In/A	Un/V 50/60Hz	gG fuse (A)								MV, MW - 3kA				
			16A	25A	32A	40A	63A	80A	100A	125A	16A	20A	25A	32A	40A
SBN / SBB / SFH / SFT / SFM	16	230V													
	25	230V	-								-	-			
	32	230V	-	-							-	-	-		
	40	400V	-	-	-						-	-	-	-	
	63	400V	-	-	-	-					-	-	-	-	-
	80	400V	-	-	-	-	-				-	-	-	-	-
	100	400V	-	-	-	-	-	-			-	-	-	-	-
	125	400V	-	-	-	-	-	-	-		-	-	-	-	-

Discrimination chart (switch on / switch off)			Short circuit withstand (kA presumed) - upstream protection												
			Fuse links								MCB				
product type	In/A	Un/V 50/60Hz	fusible gG (A)								MV, MW - 3kA				
			16A	25A	32A	40A	63A	80A	100A	125A	16A	20A	25A	32A	40A
SBN / SBB / SFH / SFT / SFM	16	230V													
	25	230V	-								-	-			
	32	230V	-	-							-	-	-		
	40	400V	-	-	-						-	-	-	-	
	63	400V	-	-	-	-					-	-	-	-	-
	80	400V	-	-	-	-	-				-	-	-	-	-
	100	400V	-	-	-	-	-	-			-	-	-	-	-
	125	400V	-	-	-	-	-	-	-		-	-	-	-	-

-  Complete protection: short circuit and overload
-  Protected against short circuit, no protection against overload.

MCB							MCB							MCB			MCCB		
MBN, MCN, MB, MT, MC, MU, - 6kA (IEC 60947-2)							NGN - 6kA NBN, NCN, NDN - 10kA NQN, NRN, NSN - 15 to 25kA (IEC 60947-2)							HLE, HLF - 10kA HMB, HMC, HMD - 15kA HMJ, HMK - 30kA (IEC 60947-2)			h3 x160A		
16A	20A	25A	32A	40A	50A	63A	16A	20A	25A	32A	40A	50A	63A	80A	100A	125A	80A	100A	125A
-	-						-	-											
-	-	-					-	-	-										
-	-	-	-				-	-	-	-									
-	-	-	-	-	-		-	-	-	-	-								
-	-	-	-	-	-	-	-	-	-	-	-	-							
-	-	-	-	-	-	-	-	-	-	-	-	-	-						
-	-	-	-	-	-	-	-	-	-	-	-	-	-	-					

MCB							MCB							MCB			MCCB		
MBN, MCN, MB, MT, MC, MU, - 6kA (IEC 60947-2)							NGN - 6kA NBN, NCN, NDN - 10kA NQN, NRN, NSN - 15 to 25kA (IEC 60947-2)							HLE, HLF - 10kA - HMB, HMC, HMD 15kA HMJ, HMK - 30kA (IEC 60947-2)			h3 x160A		
16A	20A	25A	32A	40A	50A	63A	16A	20A	25A	32A	40A	50A	63A	80A	100A	125A	80A	100A	125A
-	-						-	-											
-	-	-					-	-	-										
-	-	-	-				-	-	-	-									
-	-	-	-	-	-		-	-	-	-	-								
-	-	-	-	-	-	-	-	-	-	-	-	-							
-	-	-	-	-	-	-	-	-	-	-	-	-	-						
-	-	-	-	-	-	-	-	-	-	-	-	-	-	-					

Electrical and mechanical characteristics

General features

Part number	SVN1... / SVN2...	SVN4...		SVN3...
Designation	indicator lights	indicator lights + push buttons		push buttons
		indicator lights	push buttons	
Standard	IEC62094-1		IEC60947-5-1	
Light technology	LED light			

Electrical characteristics

Rated insulation voltage	250V		
Rated impulse withstand voltage	4kV (2kV for 12-48V version)	4kV	
Operational voltage	230V AC (1)		
Frequency	50/60Hz		
Operational thermal current	n/a	16A	
Operational current @ 230V AC12	n/a	16A	
Operational current @ 230V AC14	n/a	10A	
LED power	0,8W (230V) 0,33W (48V) 0,08W (24V) 0,018W (12V)		
Conditional short circuit current	n/a	1000A with gl 10A fuse	
IP class	IP2X		
Degree of pollution	3		

Connecting

Type of connection	cage terminals		
Connection capacity with flexible cable	0,75mm ² to 6mm ²		
Connection capacity with rigid cable	0,75m ² to 10m ²		
Terminal tightening torque	mini : 1,3Nm ; Max 2Nm ; advised 1,65Nm rigid and 1,8Nm supple		
Case material	Thermoplastic (Polyamide) comply with IEC 695-2-2		

Mechanical characteristics

Electric endurance in number of cycles	n/a	15000 (AC12); 6000 (AC14)	
Mechanical endurance in no. of operations	n/a	15000	
Life time	100000 h		
Operating temperature	-20 to +50°C		
Storage temperature	-40 to +80°C		
Climat environment	all climates		
Protection index IP	20		
Altitude	2000 m		

Installation

Mounting	DIN rail EN50.022-35		
Mounting position	performances not affected if installed vertically, horizontally or flat		

(1) except 12 to 48V indicator light (SVN131, SVN132, SVN133, SVN134, SVN135)

Technical specifications

Electrical characteristics

- supply voltage: 230 V
- load time: 36 h

Functional characteristics

- autonomy / load 24 hours: 1 hour
- autonomy / load 36 hours: 1.5 hours
- working life: 500 cycles
- illumination at 1 m: 4 lumens
- illumination at 0.5 m: 16 lumens

Environment

- working temperature: 0 to +40 °C
- storage temperature: -5 to +50 °C

Connection capacity:

1 to 4 mm²

With emergency light EE960, you will always have a small pocket lamp:

- easy to find: the device is always on the board
- battery always loaded

Functional chart

voltage supply 230V	position of switch	state of LED	state of lamp
supply 230V	« 0 »	on red	off
	« 1 »	on green	off
no supply 230V or lamp removed from socket	« 0 »	off	off
	« 1 »	off	off

Electrical connection

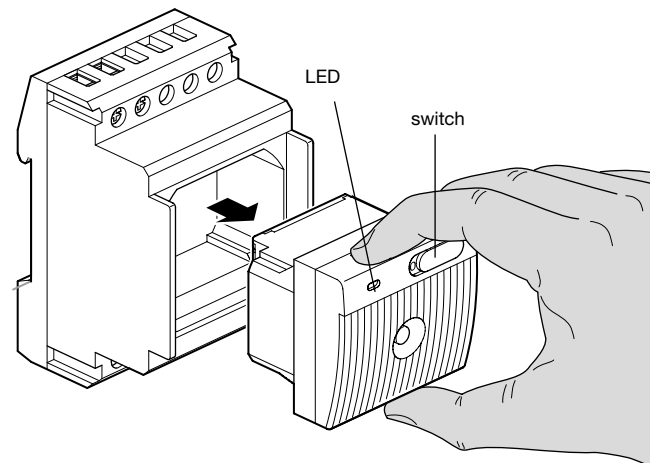
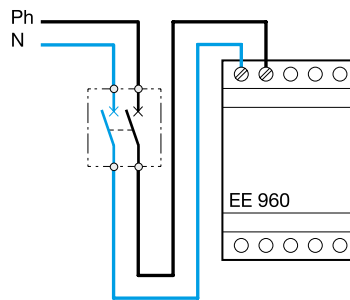

Remote controls for emergency light blocks

Technical specifications

Electrical characteristics

- supply voltage: 230 V +10 -15% 50/60 Hz
- output impulse for control
EE905: 8.4 V DC
EE910: 12 V DC
- consumption:
EE905 = 3 VA
EE910 = 4 VA

Functional characteristics

- number of remotable blocks
EE905: 60
EE910: 120

Environment

- working temperature: -10 to +40 °C
- storage temperature: -20 to +80 °C

Connection capacity:

- flexible: 1 to 6 mm²
- rigid: 1.5 to 10 mm²

Electrical connection

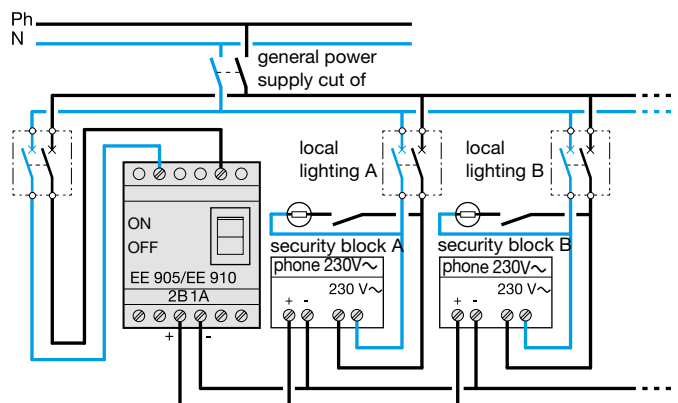

Safety transformers

These transformers are designed to ensure personal safety, their primary winding are electrically separated from their secondary windings and they are intended to feed safety extra low voltage circuits $U \leq 50V$. A thermal overload, in the primary windings, ensures that if a short circuit or an overload occurs in the output it will not damage the device.

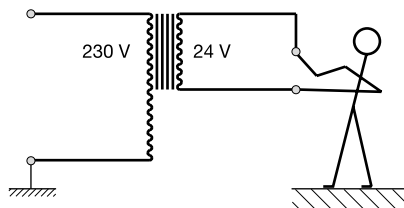

Bell transformers

Bell transformers are similar to safety transformers but the secondary voltages do not exceed 24 volts, they are also similarly protected against short circuits and overloads, by thermal protection in the primary winding.

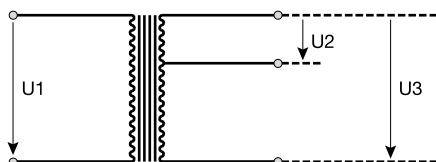

Compliance with the standards

The bell and safety transformers comply with EN 60742 (BS 3535).

Technical specification

reference	ST301	ST303	ST305	ST312	ST313	ST314	ST315
nominal power	4 VA	8 VA	16 VA	25 VA	16 VA	40 VA	63 VA
designation	bell	bell	bell	safety	safety	safety	safety
primary voltage	230 V	230 V	230 V	230 V	230 V	230 V	230 V
secondary voltage	U2 12 V In = 0.33A	8 V In = 1A	8 V In = 2A	12 V In = 2.08A	12 V In = 1.33A	12 V In = 3.33A	12 V In = 5,25 A
	U3 12 V In = 0.5A	12 V In = 0,67 A	12 V In = 1,33 A	24 V In = 1,04 A	24 V In = 0,67 A	24 V In = 1,67 A	24 V In = 2,63 A
no load secondary voltage	U2 12 V	15 V	12.4 V	14 V	15.5 V	13.7 V	13.6 V
	U3 18 V	21.8 V	18.5 V	29 V	29.7 V	26.5 V	27 V
galvanic insulation	4 kV	4 kV	4 kV	4 kV	4 kV	4 kV	4 kV
max functional temperature	35 °C	35 °C	35 °C	35 °C	35 °C	35 °C	35 °C
overload and S/C protection	thermal cut out in the primary winding						

Number of products that can be operated simultaneously by a transformer

Transformer	reference	ST301		ST303		ST305		ST312		ST313		ST314		ST315	
		8V	12V	8V	12V	8V	12V	12V	24V	12V	24V	12V	24V	12V	24V
power		4	4	8	8	16	16	25	25	16	16	40	40	63	63
bell	SU212 8/12V	1	1	3	2	5	3	-	-	-	-	-	-	-	-
buzzer	SU214 8/12V	1	1	3	2	5	3	-	-	-	-	-	-	-	-
relays	ER124 12V	-	-	-	-	-	-	4	-	2	-	7	-	8	-
	ER139 12V	-	-	-	-	-	-	2	-	1	-	3	-	4	-
	ER123 24V	-	-	-	-	-	-	-	2	-	2	-	7	-	8
	ER138 24V	-	-	-	-	-	-	-	2	-	1	-	3	-	4
contactors	ES224 24V	-	-	-	-	-	-	-	5	-	3	-	11	-	12
	ES424 24V	-	-	-	-	-	-	-	3	-	2	-	7	-	8
latching relays	EPN519 12V	-	-	-	1	-	2	3	-	2	-	4	-	4	-
	EPN513 24V	-	-	-	-	-	-	-	2	-	2	-	3	-	3
	EPN518 24V	-	-	-	-	-	-	-	4	-	3	-	7	-	8
	EPN525 24V	-	-	-	-	-	-	-	4	-	3	-	4	-	6
	EPN528 24V	-	-	-	-	-	-	-	2	-	1	-	3	-	4
	EPN541 24V	-	-	-	-	-	-	-	2	-	1	-	3	-	4

