

Air circuit breakers **hw**

Main incomers



ACB hW

from 630 to 5000A



General

-expert tips	4
-introduction to ACB fonctionnalités	6
- structure	8
- features	9
- ratings	12

References

- air circuit breakers	14
- switch disconnectors	16
- accessories	18

Technical guide

- protection trip unit (OCR)	22
- communication function	35
- remote control unit	36
- voltage module	37
- accessories	38
- circuit diagrams	56
- dimensions	58
- technical data	76
- discrimination	82
- cascading	84
- operating conditions	86
- installation conditions	87
- ACB codification	88

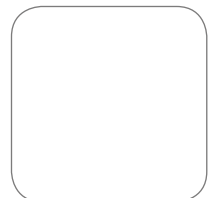

High powered air circuit breakers **hw**



The advantages for you

- High breaking capacity: full range Icu=Ics
- Optimized and compact panel size: same height and depth
- Terminal connection flexibility: horizontal/vertical terminal easy to turn at 90°
- Quick and easy mounting of accessories
- OCR: integrated communication, remote reset, ZSI, Temperature alarm
- Reliable information: fault LED info keep 1 month, fault record
- Advanced protection: low load, unbalance voltage, reserve power, low/over voltage protection
- Advanced metering: ammeter, voltage, power, energy, demand...

Technical data

- Comply with IEC 60947-2 and GB14048.2
- Rated current range: 630-5000A with 3 frames
- Breaking capacity: 50, 65, 85, 100kA
- Rated voltage: 690V
- Insulated voltage: 1000V
- Impulse voltage: 12KV
- Switch Disconnecter
- 3 kinds of OCR: Basic, Amp, Energy

Expert tips

1



Intelligent OCR
LSIGN protection, LCD display, pre-trip alarm, fault recording, remote reset.
Signal indication LED PTA/LSI/GF/COM.

4



Easy maintenance
Event record 200, fault record 250 (reserved for ever), OCR checker tool.

2



Flexible protection
Can switch ON/OFF LSIGN and thermal memory separately.

5



Flexible terminal connection
Horizontal/Vertical terminal rotate at 90° to make it easier for panel builder to mount on busbars.
For frame A up to 1600A and frame B up to 3200A.

3



Fast and economic
to build up communication network.
Communication module integrated in OCR.

6



Wide range of accessories
Including: arc shield, phase barrier, temperature sensor, dust cover (IP54), ...

Air Circuit Breaker products get their name from the fact that their breaking chambers are in the open air to allow better energy dissipation. Their electrical and mechanical strength, breaking capacity, maintainability and accessories make them ideal for protection for low voltage installations.

Characteristics of air circuit breaker

Rated current I_n (A)	<p>This is the maximum current value the circuit breaker can withstand on a permanent basis.</p> <p>This value is always given for an ambient temperature (40/50°C) in accordance with IEC 60947-2 standard if this temperature is higher, it is necessary to reduce the operating current.</p>
Rated operating voltage U_e (V)	<p>This is the voltage at which the circuit breaker can be used. The value indicated is usually the maximum value. At lower voltages, certain characteristics may differ or even be improved, such as the breaking capacity.</p>
Insulation voltage U_i (V)	<p>This is the value for the insulation performance of the device. The insulation test voltages (impulse, industrial frequency) are determined based on this value.</p>
Impulse voltage U_{imp} (kV)	<p>This value characterizes the ability of the device to withstand transient overvoltages such as lightning.</p>
Ultimate breaking capacity I_{cu} (kA)	<p>This is the maximum short-circuit current value that a circuit breaker can break at a given voltage and phase angle. The tests are executed according to the sequence O - t - CO. O represents an automatic break operation, t a time interval and CO a make operation followed by an automatic break operation. Following the test, the circuit breaker must continue to provide a minimum level of safety (isolation, dielectric strength).</p>
Standard breaking capacity I_{cs} (kA)	<p>This is the value expressed as a percentage of I_{cu}. It will be one of the following values: 25% (category A only), 50%, 75% or 100%. The circuit breaker must be capable of operating normally after breaking the I_{cs} current several times using the sequence O-CO-CO.</p>
Short-time withstand current I_{cw} (kA)	<p>This is the value of the short-circuit current that a category B circuit breaker is capable of withstanding for a defined period without altering its characteristics. This value is intended to enable discrimination between devices. The circuit breaker concerned can remain closed while the fault is eliminated by the downstream device.</p>
Rated short-circuit making capacity I_{cm} (kA peak)	<p>This is the maximum current intensity a device can make at its rated voltage according to the conditions of the standard. Devices without a protection function, such as switches, must be able to withstand short-circuit currents with a value and duration resulting from the action of the associated protection device.</p>

The ACB HW offers protection trip unit (OCR) functions and, in the event of tripping, controls the opening of the circuit-breaker, preventing it from closing again unless it has been reset by the operator.

Characteristics of OCR

Basic functions	Long-time Overload Protection (LTD)	Long-time overload protection function is for the protection of circuit overload. The protection is based on true rms value of currents.
	Short Time (STD)	Short-time short-circuit protection prevents impedance type short-circuit of power distribution system. Such kind of short-circuit normally is caused by partial short-circuit. Current normally exceed overload range but not be too large.
	Instantaneous (INST)	Instantaneous short-circuit protection functions prevents solid type short-circuit in power distribution system, which is normally caused by inter-phase fault and will generate large short-circuit current. Then an instantaneous tripping is required. Such protection is based on true rms value of currents.
	Ground Fault Trip (GFT)	The ground fault protection for equipment is used to detect current flowing through the grounding conductors which may present a hazardous condition.
	Neutral protection	Available at 100% x In of the phase currents 4P, or disabled, it is applied to the overcurrent protections L, S and I.
	Thermal Memory	To prevent unacceptable repeated or periodical overload, control unit will track and record thermal effect of overload current and trigger tripping operation when accumulated thermal effect reaches predefined threshold.
	Pre Trip Alarm (PTA)	The protection unit includes an alarm indication that will be lit continuously when the current is above 100% of the pickup setting. The settable PTA indicates the set threshold is reached before the protection is tripped.
	Fail-safe	ACB must be protected against the short-circuits although I _{sd} and I _i has set as "NON". When It detects current more than 10 x I _n , this function is operating.
	Making Current Release (MCR)	Closing on short-circuit (MCR): this function trips the ACB when a short-circuit current flows during ACB closing operation, and lock the ACB to keep it inoperative. MCR is operated by 8 times of CT rating. The function is active with an auxiliary supply. MCR is operated by 8 times of CT rating.
	Field test	Field test on circuit breakers have long provided diagnostic for the electrical components and simulate long time, short time, instantaneous delay. This function requires a control power supply (available for Amp and Energy type OCRs).
	Override	The purpose of this function is to protect ACB and wire from a current over I _{cw} . Detects a peak value of current. This function breaks the ACB without a time delay (< 30ms) Pick-up : 15 x I _{ct} .
	Fault event	Records 256 numbers of the fault info, fault phase, current value and time stamp. This function records the last wave of that time when the trip occurs and can check the wave via the communication.
System event	Records 200 numbers of the trip unit information, i.e trip unit power on, protection setting change and so on. This event can check via the communication.	
Advanced functions (only energy type)	Under Voltage Relays and Over Voltage Relay (UVR/OVR)	<ul style="list-style-type: none"> Minimum voltage protection UVR: This function calculates the minimum rms value of the three phase to phase voltages. Protection is activated when at least one of the three phase to phase voltages is below the threshold set by the user. Maximum voltage protection OVR: This function calculates the maximum rms value of the three phase to phase voltages. Protection is activated when at least one of the three phase to phase voltages are simultaneously above the threshold set by the user.
	Unbalance voltage and current	U unbal calculates the rms value of the unbalance between the three phase to phase voltages. I unbal is activated by an unbalance between the rms values of the three phase currents. This is set by a communication and monitored.
	Reverse power rP	Calculates the value of the total active power on the three phases. Is activated when the total active power of the three phases flows in the direction opposite. The direction of flow is set by the user in the "Power Sign": <ul style="list-style-type: none"> "+" corresponds to the normal direction of flow, i.e from the top on the acb to the bottom; "-" is the opposite.

Front

Fixed type



Draw-out type

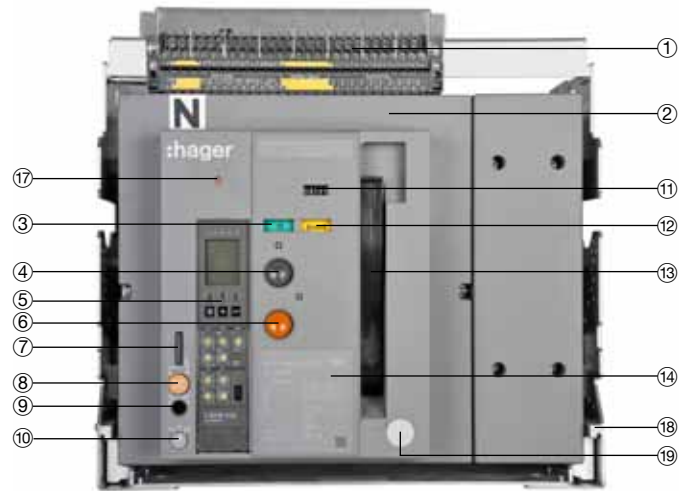

Chassis

Inside



Rear

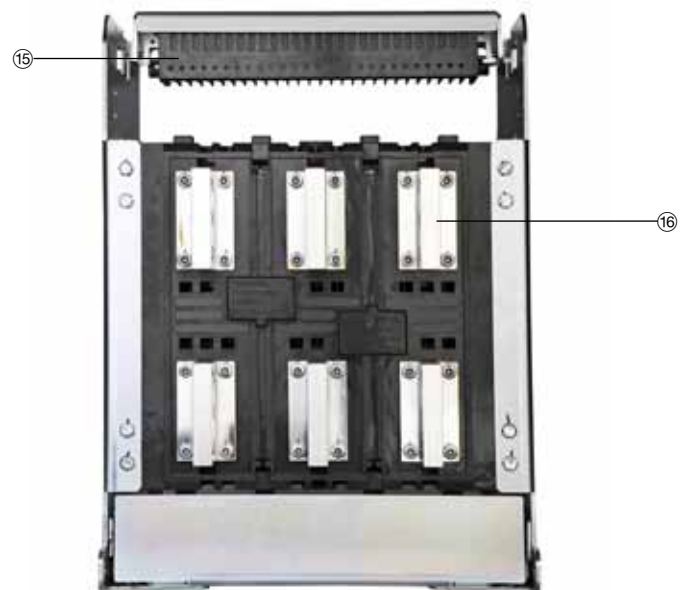

- ① Control terminal
- ② Front cover
- ③ Close/Open indicator
- ④ Close button
- ⑤ Protection trip relay (OCR)
- ⑥ Open button
- ⑦ Position lock device

- ⑧ Position lock release button
- ⑨ Draw-in/out handle insertion hole
- ⑩ Position indicator
- ⑪ Counter
- ⑫ Charged/Discharged indicator
- ⑬ Manual charging handle
- ⑭ Name plate

- ⑮ Arc shield
- ⑯ Terminal busbar
- ⑰ OCR & Alarm switch reset button
- ⑱ Draw-in/out guide rail
- ⑲ Draw-in/out handle

Body side

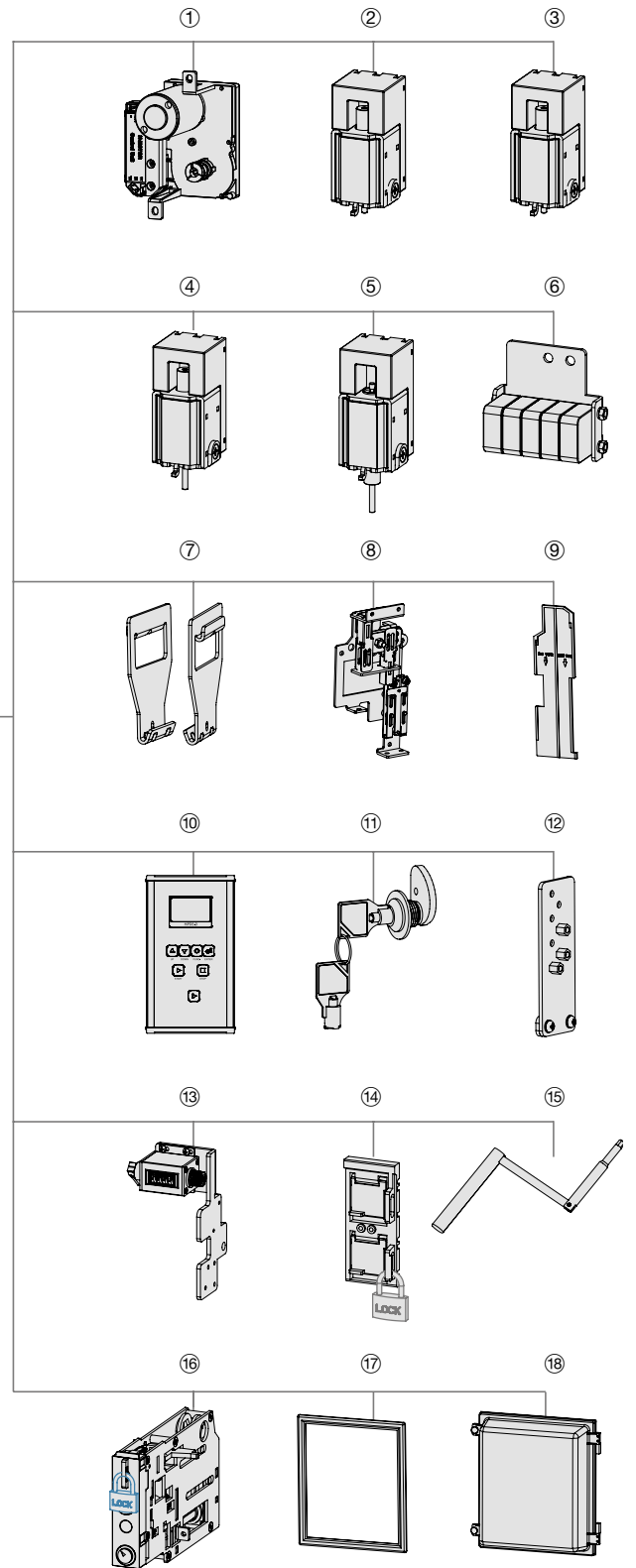

- ① Motor operator
- ② Closing coil
- ③ Shunt trip coil
- ④ Second shunt trip coil
- ⑤ Under voltage trip coil
- ⑥ Auxiliary switch

- ⑦ Lifting lug
- ⑧ Mechanical interlock kit
- ⑨ Phase insulation barrier
- ⑩ OCR portable checker
- ⑪ Key lock device
- ⑫ Wrong insertion preventer

- ⑬ Counter
- ⑭ ON/OFF button cover
- ⑮ Draw-in/out handle
- ⑯ Draw-in/out mechanism
- ⑰ Door flange
- ⑱ Dust cover

Chassis side (cradle)

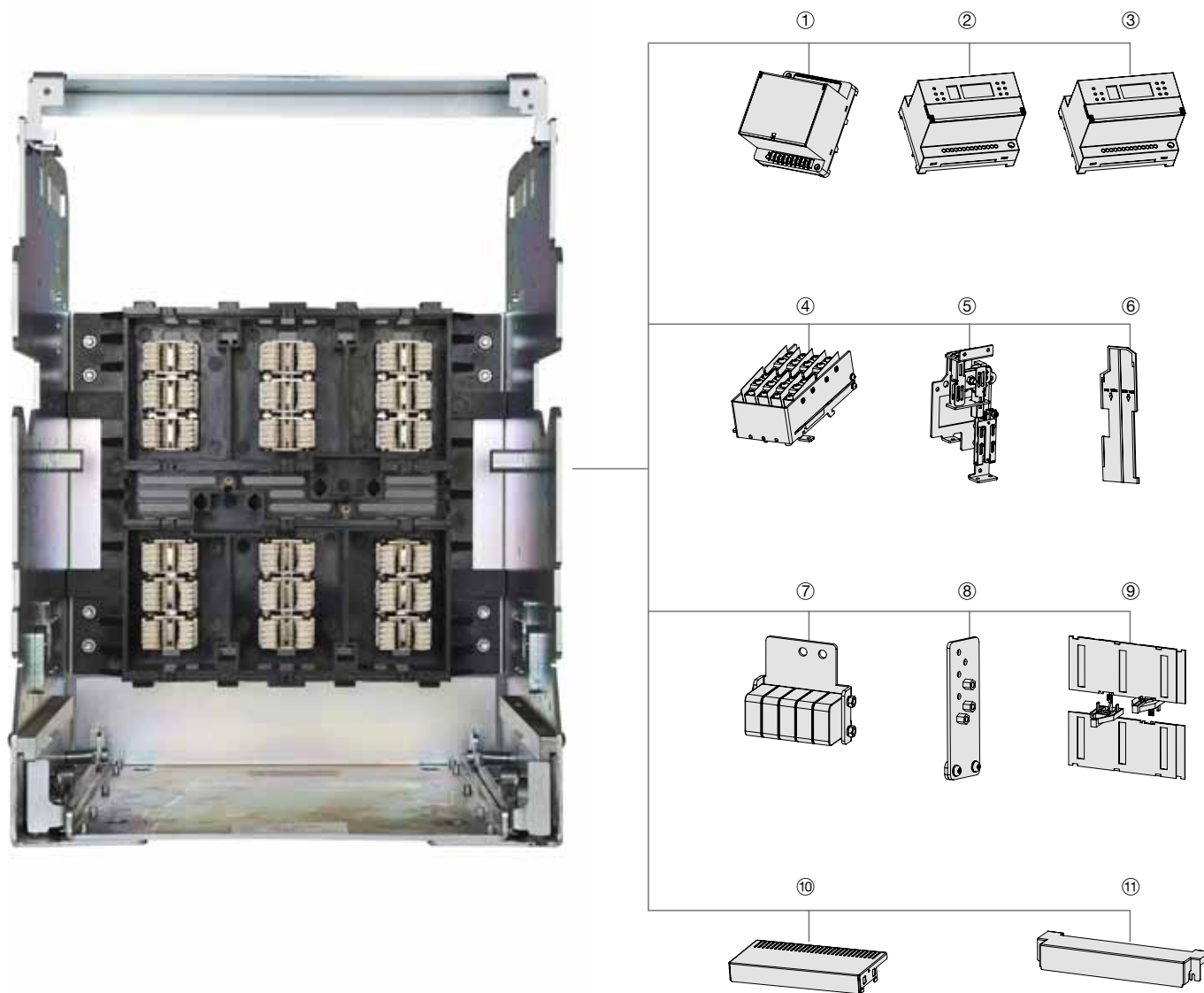

- ① UVT time delay controller
- ② Remote operation module
- ③ Temperature detection module
- ④ Position switch
- ⑤ Mechanical interlock kit
- ⑥ Phase insulation barrier
- ⑦ Mechanical operated cell (MOC) switch

- ⑧ Wrong insertion preventer
- ⑨ Safety shutter
- ⑩ Arc shield
- ⑪ Control terminal protection cover

Accessories included as standard:

- Auxiliary switch 4NO/5NC
- Door flange for IP30
- Control terminal protection cover (for draw-out type)
- Safety shutter lock (for draw-out type)
- Rotary handle (for draw-out type)

Flexible terminal connections

Connectors can be set horizontally and vertically, which allows an easy mounting by adapting their position to the busbars. Horizontal/vertical terminals rotate at 90° to make easier panel builder's convenience regarding busbar connection. ¹⁾

Standard connection

Vertical

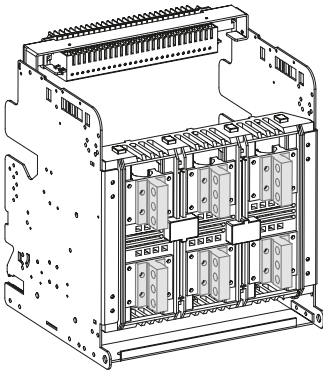

Horizontal

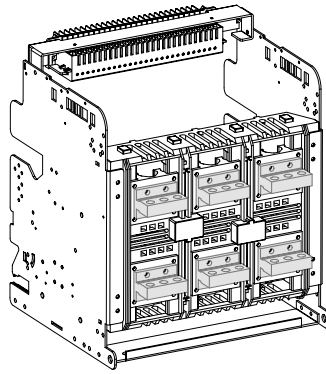

Front

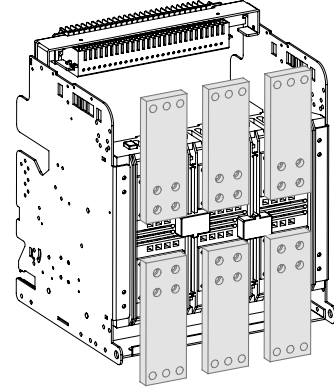

Mixed connection (top / bottom)

Vertical / horizontal

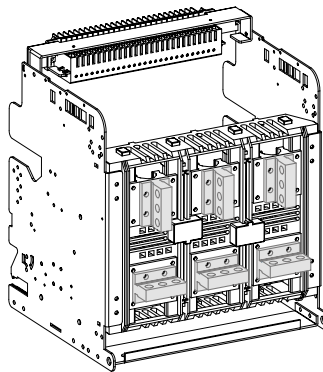

Horizontal / vertical

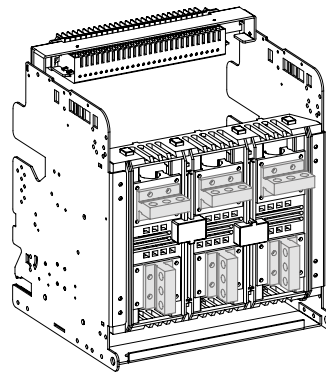

Vertical / front

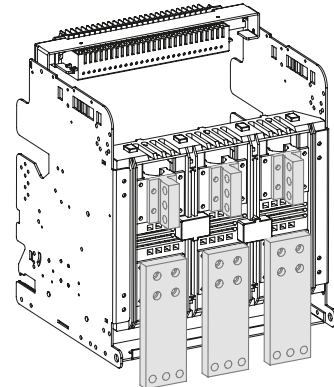

¹⁾ For frame A up to 1600A and frame B up to 3200A.

Frame			A		B			C	
Type			H	N	N	S	P	P	
Rated current	A		630-2000		630-4000			3200-5000	
Rated operating voltage (Ue)	V		690						
Rated insulation voltage (Ui)	V		1000						
Rated impulse withstand voltage (Uimp)	KV		12						
Frequency	Hz		50/60						
Number of poles	poles		3-4						
Current setting range (...x In max)	Ir		0.4-1.0						
Rated current of neutral pole (...% x In)	%/In		100%						
Rated breaking capacity (Icu)	AC 690/600/550V	KA	36	50	50	65	85	85	
	AC 415/380/220V		50	65	65	85	100	100	
Rated service breaking capacity (Ics)	AC 690/600/550V	KA	100% Icu						
	AC 415/380/220V								
Rated short-time capacity (Icw)	1s	KA	50	65	65	85	85	85	
	3s		36	36	50	55	65	65	
Rated making capacity (kA peak) (Icm)	AC 690/600/550V	KA	76	105	105	143	187	187	
	AC 415/380/220V		105	143	143	187	220	220	
Utilization category (according to IEC 60947-2)			B						
Time									
Maximum total breaking time	ms		40						
Closing operating time	motor charging time	s	10						
	max. closing time	ms	40						
Operating cycle									
Mechanical life cycle	without maintenance	times	20000		15000		10000		
	with maintenance		30000		20000		20000		
Electrical life cycle	without maintenance	times	5000		06-20: 10000 25-40: 5000		2000		
	with maintenance		10000		06-20: 15000 25-40: 10000		5000		
Dimensions									
External dimension (W x H x D, except busbar)	fixed type	3 pole	mm	337x404x296		408x404x296		633x404x296	
		4 pole		422x404x296		523x404x296		803x404x296	
	draw-out type	3 pole		328x460x368		399x460x368		624x460x368	
		4 pole		413x460x368		514x460x368		794x460x368	
Weight	fixed type	3 pole	kg	34		06-32: 44 40: 61		76	
		4 pole		44		06-32: 55 40: 81		81	
	draw-out type	3 pole		63		06-32: 87 40: 107		145	
		4 pole		80		06-32: 130 40: 161		173	

Fixed type

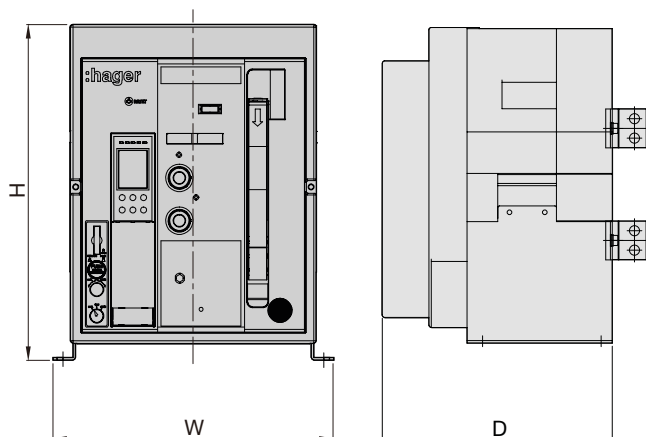

Draw-out type

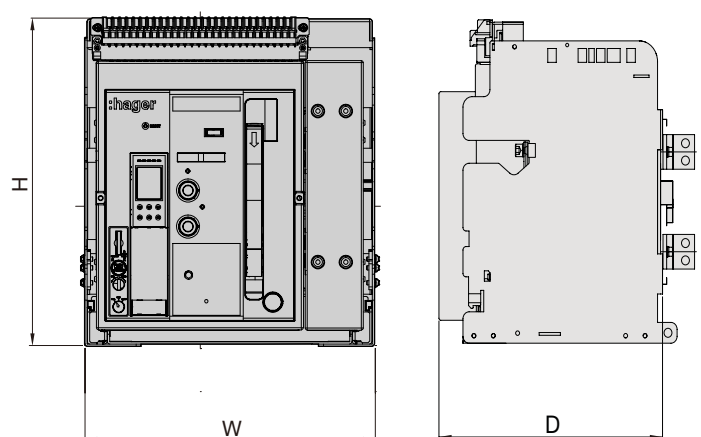

Frame			A	B	C	
Type			N....A	N....A	P....A	
Rated current	A		630-2000	630-4000	3200-5000	
Rated operating voltage (Ue)	V		690			
Rated insulation voltage (Ui)	V		1000			
Rated impulse withstand voltage (Uimp)	KV		12			
Frequency	Hz		50/60			
Number of poles	poles		3-4			
Rated current of neutral pole (...% x In)	%/In		100%			
Rated short-time capacity (Icw)	1s	KA	65	65	85	
	3s		36	50	65	
Rated making capacity (kA peak) (Icm)	AC 690/600/550V	KA	105	105	187	
	AC 415/380/220V		143	143	220	
Utilization category (according to IEC 60947-3)			AC23			
Time						
Maximum total breaking time	ms		40			
Closing operating time	motor charging time	s	10			
	max. closing time	ms	40			
Operating cycle						
Mechanical life cycle	without maintenance		20000	15000	10000	
	with maintenance		30000	20000	20000	
Electrical life cycle	without maintenance	times	5000	06-20: 10000	2000	
				25-40: 5000		
	with maintenance		10000	06-20: 15000	5000	
				25-40: 10000		
Dimensions						
External dimension (W x H x D, except busbar)	fixed type	3 pole	mm	337x404x296	408x404x296	633x404x296
		4 pole		422x404x296	523x404x296	803x404x296
	draw-out type	3 pole		328x460x368	399x460x368	624x460x368
		4 pole		413x460x368	514x460x368	794x460x368
Weight	fixed type	3 pole	kg	34	06-32: 44	76
					40: 61	
	4 pole	44		06-32: 55	81	
				40: 81		
	draw-out type	3 pole		63	06-32: 87	145
					40: 107	
	4 pole	80	06-32: 130	173		
			40: 161			

Fixed type

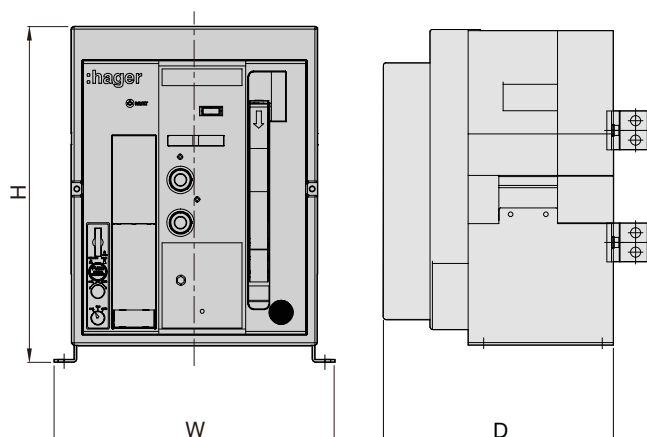

Draw-out type

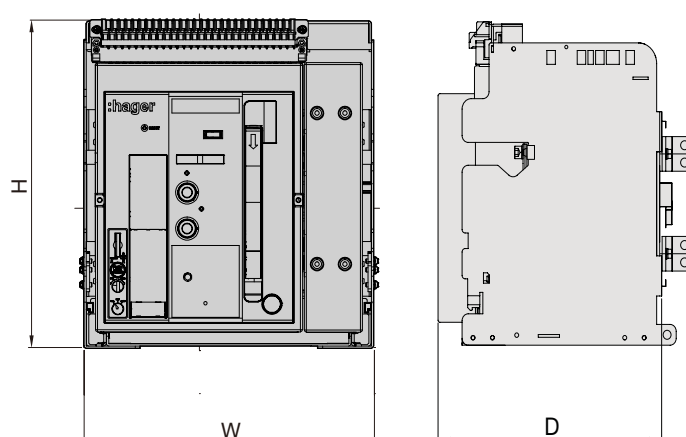



HWAN416ED

Description	Rating (A)	nr. of poles	Cat ref.		
			draw-out type	fixed type	
Frame A lcu=lcs=50KA lcu=lcs=lw	630A	3	HWAH306ED	HWAH306EF	
	800A	3	HWAH308ED	HWAH308EF	
	1000A	3	HWAH310ED	HWAH310EF	
	1250A	3	HWAH312ED	HWAH312EF	
	1600A	3	HWAH316ED	HWAH316EF	
	2000A	3	HWAH320ED	HWAH320EF	
	630A	4	HWAH406ED	HWAH406EF	
	800A	4	HWAH408ED	HWAH408EF	
	1000A	4	HWAH410ED	HWAH410EF	
	1250A	4	HWAH412ED	HWAH412EF	
	1600A	4	HWAH416ED	HWAH416EF	
	2000A	4	HWAH420ED	HWAH420EF	
	Frame A lcu=lcs=65KA lcu=lcs=lw	630A	3	HWAN306ED	HWAN306EF
		800A	3	HWAN308ED	HWAN308EF
1000A		3	HWAN310ED	HWAN310EF	
1250A		3	HWAN312ED	HWAN312EF	
1600A		3	HWAN316ED	HWAN316EF	
2000A		3	HWAN320ED	HWAN320EF	
630A		4	HWAN406ED	HWAN406EF	
800A		4	HWAN408ED	HWAN408EF	
1000A		4	HWAN410ED	HWAN410EF	
1250A		4	HWAN412ED	HWAN412EF	
1600A		4	HWAN416ED	HWAN416EF	
2000A		4	HWAN420ED	HWAN420EF	
Frame B lcu=lcs=65KA lcu=lcs=lw		630A	3	HWBN306ED	HWBN306EF
		800A	3	HWBN308ED	HWBN308EF
	1000A	3	HWBN310ED	HWBN310EF	
	1250A	3	HWBN312ED	HWBN312EF	
	1600A	3	HWBN316ED	HWBN316EF	
	2000A	3	HWBN320ED	HWBN320EF	
	2500A	3	HWBN325ED	HWBN325EF	
	3200A	3	HWBN332ED	HWBN332EF	
	4000A	3	HWBN340ED	HWBN340EF	
	630A	4	HWBN406ED	HWBN406EF	
	800A	4	HWBN408ED	HWBN408EF	
	1000A	4	HWBN410ED	HWBN410EF	
	1250A	4	HWBN412ED	HWBN412EF	
	1600A	4	HWBN416ED	HWBN416EF	
	2000A	4	HWBN420ED	HWBN420EF	
	2500A	4	HWBN425ED	HWBN425EF	
3200A	4	HWBN432ED	HWBN432EF		
4000A	4	HWBN440ED	HWBN440EF		



HWBN416ED



HWBS416ED

Description	Rating (A)	nr. of poles	Cat ref.	
			draw-out type	fixed type
Frame B Icu=Ics=85KA Icu=Ics=Icw	630A	3	HWBS306ED	HWBS306EF
	800A	3	HWBS308ED	HWBS308EF
	1000A	3	HWBS310ED	HWBS310EF
	1250A	3	HWBS312ED	HWBS312EF
	1600A	3	HWBS316ED	HWBS316EF
	2000A	3	HWBS320ED	HWBS320EF
	2500A	3	HWBS325ED	HWBS325EF
	3200A	3	HWBS332ED	HWBS332EF
	4000A	3	HWBS340ED	HWBS340EF
	630A	4	HWBS406ED	HWBS406EF
	800A	4	HWBS408ED	HWBS408EF
	1000A	4	HWBS410ED	HWBS410EF
	1250A	4	HWBS412ED	HWBS412EF
	1600A	4	HWBS416ED	HWBS416EF
	2000A	4	HWBS420ED	HWBS420EF
	2500A	4	HWBS425ED	HWBS425EF
3200A	4	HWBS432ED	HWBS432EF	
4000A	4	HWBS440ED	HWBS440EF	
Frame B Icu=Ics=100KA Icw=85KA	630A	3	HWBP306ED	HWBP306EF
	800A	3	HWBP308ED	HWBP308EF
	1000A	3	HWBP310ED	HWBP310EF
	1250A	3	HWBP312ED	HWBP312EF
	1600A	3	HWBP316ED	HWBP316EF
	2000A	3	HWBP320ED	HWBP320EF
	2500A	3	HWBP325ED	HWBP325EF
	3200A	3	HWBP332ED	HWBP332EF
	4000A	3	HWBP340ED	HWBP340EF
	630A	4	HWBP406ED	HWBP406EF
	800A	4	HWBP408ED	HWBP408EF
	1000A	4	HWBP410ED	HWBP410EF
	1250A	4	HWBP412ED	HWBP412EF
	1600A	4	HWBP416ED	HWBP416EF
	2000A	4	HWBP420ED	HWBP420EF
	2500A	4	HWBP425ED	HWBP425EF
3200A	4	HWBP432ED	HWBP432EF	
4000A	4	HWBP440ED	HWBP440EF	
Frame C Icu=Ics=100KA Icw=85KA	3200A	3	HWCP332ED	HWCP332EF
	4000A	3	HWCP340ED	HWCP340EF
	5000A	3	HWCP350ED	HWCP350EF
	3200A	4	HWCP432ED	HWCP432EF
	4000A	4	HWCP440ED	HWCP440EF
5000A	4	HWCP450ED	HWCP450EF	



HWCP432ED



HWAN416EDA



HWBN416EDA

Description	Rating (A)	nr. of poles	Cat ref.		
			draw-out type	fixed type	
Frame A Icw=50KA	630A	3	HWAH306EDA	HWAH306EFA	
	800A	3	HWAH308EDA	HWAH308EFA	
	1000A	3	HWAH310EDA	HWAH310EFA	
	1250A	3	HWAH312EDA	HWAH312EFA	
	1600A	3	HWAH316EDA	HWAH316EFA	
	2000A	3	HWAH320EDA	HWAH320EFA	
	630A	4	HWAH406EDA	HWAH406EFA	
	800A	4	HWAH408EDA	HWAH408EFA	
	1000A	4	HWAH410EDA	HWAH410EFA	
	1250A	4	HWAH412EDA	HWAH412EFA	
	1600A	4	HWAH416EDA	HWAH416EFA	
	2000A	4	HWAH420EDA	HWAH420EFA	
	Frame A Icw=65KA	630A	3	HWAN306EDA	HWAN306EFA
		800A	3	HWAN308EDA	HWAN308EFA
1000A		3	HWAN310EDA	HWAN310EFA	
1250A		3	HWAN312EDA	HWAN312EFA	
1600A		3	HWAN316EDA	HWAN316EFA	
2000A		3	HWAN320EDA	HWAN320EFA	
630A		4	HWAN406EDA	HWAN406EFA	
800A		4	HWAN408EDA	HWAN408EFA	
1000A		4	HWAN410EDA	HWAN410EFA	
1250A		4	HWAN412EDA	HWAN412EFA	
1600A		4	HWAN416EDA	HWAN416EFA	
2000A		4	HWAN420EDA	HWAN420EFA	
Frame B Icw=65KA		630A	3	HWBN306EDA	HWBN306EFA
		800A	3	HWBN308EDA	HWBN308EFA
	1000A	3	HWBN310EDA	HWBN310EFA	
	1250A	3	HWBN312EDA	HWBN312EFA	
	1600A	3	HWBN316EDA	HWBN316EFA	
	2000A	3	HWBN320EDA	HWBN320EFA	
	2500A	3	HWBN325EDA	HWBN325EFA	
	3200A	3	HWBN332EDA	HWBN332EFA	
	4000A	3	HWBN340EDA	HWBN340EFA	
	630A	4	HWBN406EDA	HWBN406EFA	
	800A	4	HWBN408EDA	HWBN408EFA	
	1000A	4	HWBN410EDA	HWBN410EFA	
	1250A	4	HWBN412EDA	HWBN412EFA	
	1600A	4	HWBN416EDA	HWBN416EFA	
2000A	4	HWBN420EDA	HWBN420EFA		
2500A	4	HWBN425EDA	HWBN425EFA		
3200A	4	HWBN432EDA	HWBN432EFA		
4000A	4	HWBN440EDA	HWBN440EFA		



HWBS416EDA

Description	Rating (A)	nr. of poles	Cat ref.	
			draw-out type	fixed type
Frame B Icw=85KA	630A	3	HWBS306EDA	HWBS306EFA
	800A	3	HWBS308EDA	HWBS308EFA
	1000A	3	HWBS310EDA	HWBS310EFA
	1250A	3	HWBS312EDA	HWBS312EFA
	1600A	3	HWBS316EDA	HWBS316EFA
	2000A	3	HWBS320EDA	HWBS320EFA
	2500A	3	HWBS325EDA	HWBS325EFA
	3200A	3	HWBS332EDA	HWBS332EFA
	4000A	3	HWBS340EDA	HWBS340EFA
	630A	4	HWBS406EDA	HWBS406EFA
	800A	4	HWBS408EDA	HWBS408EFA
	1000A	4	HWBS410EDA	HWBS410EFA
	1250A	4	HWBS412EDA	HWBS412EFA
	1600A	4	HWBS416EDA	HWBS416EFA
	2000A	4	HWBS420EDA	HWBS420EFA
	2500A	4	HWBS425EDA	HWBS425EFA
	3200A	4	HWBS432EDA	HWBS432EFA
	4000A	4	HWBS440EDA	HWBS440EFA
	Frame B Icw=85KA	630A	3	HWBP306EDA
800A		3	HWBP308EDA	HWBP308EFA
1000A		3	HWBP310EDA	HWBP310EFA
1250A		3	HWBP312EDA	HWBP312EFA
1600A		3	HWBP316EDA	HWBP316EFA
2000A		3	HWBP320EDA	HWBP320EFA
2500A		3	HWBP325EDA	HWBP325EFA
3200A		3	HWBP332EDA	HWBP332EFA
4000A		3	HWBP340EDA	HWBP340EFA
630A		4	HWBP406EDA	HWBP406EFA
800A		4	HWBP408EDA	HWBP408EFA
1000A		4	HWBP410EDA	HWBP410EFA
1250A		4	HWBP412EDA	HWBP412EFA
1600A		4	HWBP416EDA	HWBP416EFA
2000A		4	HWBP420EDA	HWBP420EFA
2500A		4	HWBP425EDA	HWBP425EFA
3200A		4	HWBP432EDA	HWBP432EFA
4000A		4	HWBP440EDA	HWBP440EFA
Frame C Icw=85KA		3200A	3	HWCP332EDA
	4000A	3	HWCP340EDA	HWCP340EFA
	5000A	3	HWCP350EDA	HWCP350EFA
	3200A	4	HWCP432EDA	HWCP432EFA
	4000A	4	HWCP440EDA	HWCP440EFA
	5000A	4	HWCP450EDA	HWCP450EFA



HWCP432EDA



HWY750



HWW633



HWX544

Description	Characteristics	Pack qty.	Cat. ref.
Chassis	frame A, 3 pole, 630-1600A	1	HWY750
	frame A, 4 pole, 630-1600A	1	HWY751
	frame A, 3 pole, 2000A	1	HWY752
	frame A, 4 pole, 2000A	1	HWY753
	frame B, 3 pole, 630-2500A	1	HWY754
	frame B, 4 pole, 630-2500A	1	HWY755
	frame B, 3 pole, 3200A	1	HWY756
	frame B, 4 pole, 3200A	1	HWY757
	frame B, 3 pole, 4000A vertical	1	HWY758
	frame B, 4 pole, 4000A vertical	1	HWY759
	frame B, 3 pole, 4000A horizontal	1	HWY760
	frame B, 4 pole, 4000A horizontal	1	HWY761
	frame C, 3 pole, 3200-5000A vertical	1	HWY762
	frame C, 4 pole, 3200-5000A vertical	1	HWY763
	frame C, 3 pole, 3200-5000A horizontal	1	HWY764
	frame C, 4 pole, 3200-5000A horizontal	1	HWY765
Protection trip units (OCR)	LI	1	HWX611
	LSI	1	HWX612
	LSIG	1	HWX613
	Amp LI	1	HWX621
	Amp LSI	1	HWX622
	Amp LSIG	1	HWX623
	Energy LSIG	1	HWX633
OCR portable checker		1	HWY649
Voltage module		1	HWY650
OCR manual reset and alarm switch reset (for draw-out type)		1	HWY651
OCR manual reset and alarm switch reset (for fixed type)		1	HWY652
Remote control unit	RCU	1	HWY639
Remote control temperature unit	RCTU	1	HWY654
Remote control temperature unit + temperature sensor		1	HWY655
Temperature sensor		1	HWY640
Temperature sensor support	for frame A, 3 pole	1	HWY690
	for frame A, 4 pole	1	HWY691
	for frame B, 3 pole	1	HWY692
	for frame B, 4 pole	1	HWY693
	for frame C, 3 pole	1	HWY695
	for frame C, 4 pole	1	HWY696
Motor operators MO	DC 24V	1	HWX541
	DC 48V	1	HWX542
	AC/DC 110V	1	HWX543
	AC/DC 220V	1	HWX544
	AC 380/415V	1	HWX545
	AC 440V	1	HWX546
Motor controller unit only		1	HWW068
Motor ON/OFF switch only		1	HWW069



HWX501



HWX514



HWX573

Description	Characteristics	Pack qty.	Cat. ref.
Closing coils CC	DC 24V	1	HWX551
	DC 48V	1	HWX552
	AC/DC 110V	1	HWX553
	AC/DC 220V	1	HWX554
	AC 380/415V	1	HWX555
	AC440V	1	HWX556
Shunt trip coils SH	DC 24V	1	HWX501
	DC 48V	1	HWX502
	AC/DC 110V	1	HWX503
	AC/DC 220V	1	HWX504
	AC380/415V	1	HWX505
	AC 440V	1	HWX506
Secondary trip coils sSH	DC 24V	1	HWX521
	DC 48V	1	HWX522
	AC/DC 110V	1	HWX523
	AC/DC 220/250V	1	HWX524
	AC 380/415V	1	HWX525
	AC 440V	1	HWX526
Under voltage trip coils (instantaneous) UVT	DC 24V	1	HWX511
	DC 48V	1	HWX512
	AC/DC 110V	1	HWX513
	AC/DC 220/250V	1	HWX514
	AC 380/415V	1	HWX515
	AC 440V	1	HWX516
UVT time delay controllers	AC/DC 110V	1	HWX533
	AC/DC 220/250V	1	HWX534
	AC 380/415V	1	HWX535
	AC 440V	1	HWX536
Auxiliary switch (AX) draw-out type	4NO + 5NC	1	HWX560
Auxiliary switch (AX) fixed type	4NO + 5NC	1	HWX561
Mechanical operated cell switch (additional AX)	5NO + 5NC	1	HWX565
Ready to close contact RTC draw-out type	1NO	1	HWX547
Ready to close contact RTC fixed type	1NO	1	HWX548
Position switches	isolated 1C, test 1C, connected 2C	1	HWX570
	inserted 1C, isolated 1C, test 1C, connected 1C	1	HWX571
	inserted 1C, isolated 1C, test 3C, connected 3C	1	HWX572
	inserted 2C, isolated 2C, test 2C, connected 2C	1	HWX573
Counter		1	HWY638



HWY660



HWY642



HWY6xx



HWY701



HWY706





HWW268

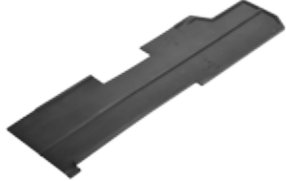

HWY500

Description	Characteristics	Pack qty.	Cat. ref.
Safety shutters	frame A, 630-2000A, 3 pole	1	HWY660
	frame A, 630-2000A, 4 pole	1	HWY661
	frame B, 630-4000A, 3 pole	1	HWY662
	frame B, 630-4000A, 4 pole	1	HWY663
	frame C, 3200-5000A, 3 pole	1	HWY664
	frame C, 3200-5000A, 4 pole	1	HWY665
Rotary handle for draw-out type		1	HWY644
Lifting lug		1	HWY648
Wrong insertion preventer for draw-out type		1	HWY636
Door flange	for IP30	1	HWY641
Dust cover	for IP54	1	HWY642
ON/OFF button cover	with padlock hole	1	HWY632
Key cylinder lock in open position	type 1	1	HWY633
	type 2	1	HWY634
	type 3	1	HWY635
	type 4	1	HWY646
	type 5	1	HWY647
	type 6	1	HWY656
	type 7	1	HWY657
	type 8	1	HWY658
	type 9	1	HWY659
Key Ronis lock in open position	type 1 - K1L1/12	1	HWY701
	type 2 - K2L2/12/23	1	HWY702
	type 3 - K3L3/23	1	HWY703
	type 4 - K12L12	1	HWY704
	type 5 - K23L23	1	HWY705
Key Castell lock in open position	type 1 - A	1	HWY706
	type 2 - B	1	HWY707
	type 3 - A_B	1	HWY708
Neutral CT	630A	1	HWW260
	800A	1	HWW261
	1000A	1	HWW262
	1250A	1	HWW263
	1600A	1	HWW264
	2000A	1	HWW265
	2500A	1	HWW266
	3200A	1	HWW267
	4000A	1	HWW268
	5000A	1	HWW269
Mechanical interlock mechanism with cables	draw-out type, 2 way	1	HWY500
	draw-out type, 3 way	1	HWY501
	fixed type, 2 way	1	HWY502
	fixed type, 3 way	1	HWY503
Adaptor kit for Ronis/Castell locks		1	HWY697

	Description	Characteristics	Pack qty.	Cat. ref.
	Mechanical interlock parts inside breaker (trip rod + bush)	frame A, draw-out type	1	HWY620
		frame A, fixed type	1	HWY621
		frame B, draw-out type	1	HWY622
		frame B, fixed type	1	HWY623
		frame C 3 pole, draw-out type	1	HWY624
		frame C 3 pole, fixed type	1	HWY625
		frame C 4 pole, draw-out type	1	HWY626
		frame C 4 pole, fixed type	1	HWY627
 HWY570	Mechanical interlock (full set)	draw-out type, frame A, 2 way	1	HWY570
		draw-out type, frame A, 3 way	1	HWY571
		draw-out type, frame B, 2 way	1	HWY572
		draw-out type, frame B, 3 way	1	HWY573
		draw-out type, frame C 3 pole, 2 way	1	HWY574
		draw-out type, frame C 4 pole, 2 way	1	HWY576
		draw-out type, frame C 3 pole, 3 way	1	HWY575
		draw-out type, frame C 4 pole, 3 way	1	HWY577
		fixed type, frame A, 2 way	1	HWY580
		fixed type, frame A, 3 way	1	HWY581
		fixed type, frame B, 2 way	1	HWY582
		fixed type, frame B, 3 way	1	HWY583
		fixed type, frame C 3 pole, 2 way	1	HWY584
		fixed type, frame C 4 pole, 2 way	1	HWY586
		fixed type, frame C 3 pole, 3 way	1	HWY585
		fixed type, frame C 4 pole, 3 way	1	HWY587
	Cable 3m	for mechanical interlock	1	HWY508
	Cable 5m	for mechanical interlock	1	HWY509
	Horizontal / vertical terminals	for frame A 3 pole, 630-1600A	1	HWY610
		for frame A 4 pole, 630-1600A	1	HWY611
		for frame B 3 pole, 630-3200A	1	HWY612
		for frame B 4 pole, 630-3200A	1	HWY613
	Phase insulation barrier	3 pole (2 units)	1	HWY630
		4 pole (3 units)	1	HWY631
	Control terminal protection cover	for draw-out type	1	HWY637
 HWY630	Arc shield (for draw-out type)	for frame A 3 pole, 630-2000A	1	HWY670
		for frame A 4 pole, 630-2000A	1	HWY671
		for frame B 3 pole, 630-4000A	1	HWY672
		for frame B 4 pole, 630-4000A	1	HWY673
		for frame C 3 pole, 3200-5000A	1	HWY674
		for frame C 4 pole, 3200-5000A	1	HWY675
	Fixed type connector plug	pre-wired kit length: 3m	1	HWY065
 HWY672				

Characteristics

Reference		HWX611	HWX612	HWX613	HWX621	HWX622	HWX623	HWX633
Type		LI	LSI	LSIG	LI Amp	LSI Amp	LSIG Amp	Energy
Frequency 50/60 Hz		•	•	•	•	•	•	•
OCR								
Power	externals	•	•	•	•	•	•	•
	self	•	•	•	•	•	•	•
Protection function	LTD	•	•	•	•	•	•	•
	STD	-	•	•	-	•	•	•
	INST	•	•	•	•	•	•	•
	PTA	-	-	-	•	•	•	•
	GFT	-	-	•	-	-	•	•
	neutral protection	•	•	•	•	•	•	•
	fail safe	•	•	•	•	•	•	•
	MCR	•	•	•	•	•	•	•
Indication	long time pick up LED	•	•	•	•	•	•	•
	fault LED	L, I	L, S/I	L, S/I, G	L, I PTA	L, S/I PTA	L, S/I, G PTA	L, S/I, G PTA
	LCD display, Amp and measurement	-	-	-	•	•	•	-
	LCD display, Amp, Energy, voltage, power, energy, demand and measurement	-	-	-	-	-	-	•
Digital output	separately continuous contact	• (2NO) L, I	• (2NO) L, S/I	• (3NO) L, S/I, G	• (3NO) L, I, PTA	• (3NO) L, S/I, PTA	• (4NO) L, S/I, G, PTA	• (4NO) L, S/I, G, PTA
ZSI		•	•	•	•	•	•	•
Reset button		•	•	•	•	•	•	•
Advanced functions	COM	-	-	-	•	•	•	•
	event / fault recording	-	-	-	•	•	•	•
	under/over voltage protection	-	-	-	-	-	-	•
	unbalanced current / voltage protection	-	-	-	-	-	-	•
	reverse power protection	-	-	-	-	-	-	•
	power P, Q, S, power factor, 3 phases voltage	-	-	-	-	-	-	•
	demand current / voltage	-	-	-	-	-	-	•

Overview

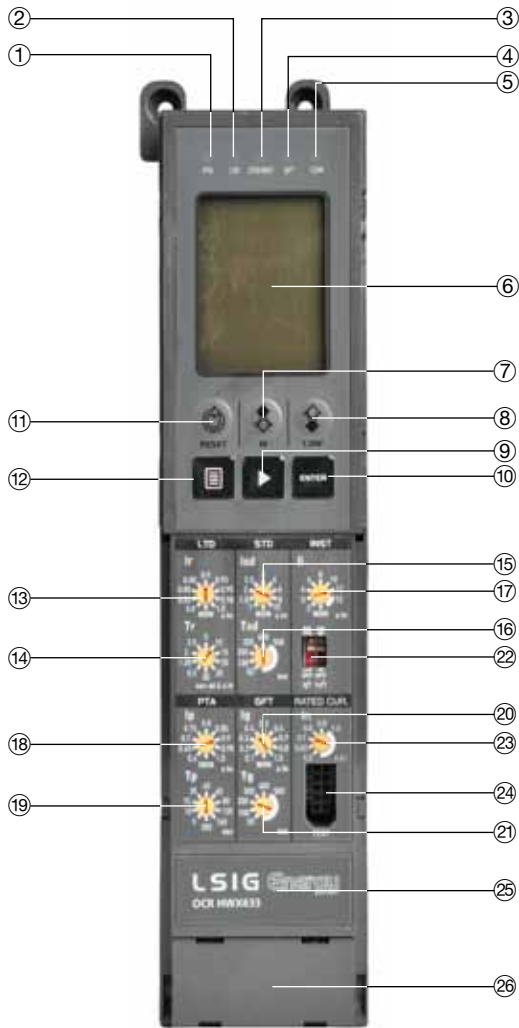

- | | |
|------------------------|--|
| ① PTA signal LED | ⑮ STD pick up setting |
| ② LTD signal LED | ⑯ STD time setting |
| ③ STD/INST signal LED | ⑰ INST pick up setting |
| ④ GFT signal LED | ⑱ PTA pick up setting |
| ⑤ Com. signal LED | ⑲ PTA time setting |
| ⑥ LCD screen | ⑳ GFT pick up setting |
| ⑦ STD/INST test button | ㉑ GFT time setting |
| ⑧ LTD test button | ㉒ GFT/STD (Inverse time setting),
MCR ON/OFF setting switch |
| ⑨ Movement button | ㉓ In (rated current) setting |
| ⑩ Enter button | ㉔ Temporary test connection jack |
| ⑪ Reset button | ㉕ Model name |
| ⑫ Menu button | ㉖ Battery |
| ⑬ LTD pick up setting | |
| ⑭ LTD time setting | |

➔ Self power works normally at larger than 10% for 3 phase, 30% for single phase.

Basic OCR: HWX611, HWX612, HWX613



- Overload protection
 - Long time delay
- Short circuit protection
 - Short time delay, instantaneous trip
 - I²t on/off optional (for STD)
- Ground fault protection
 - I²t on/off optional (for GFT)
- Neutral wire protection
 - 3P: No protection
 - 4P: 100 % x I_n
 - LTD, STD, INST protection
- Realization of protective coordination by ZSI (zone selective interlocking)

- LI (2 digital output - NO)
- LSI (2 digital output - NO)
- LSI_G (3 digital output - NO)
 - Contact specification

Rating	Nominal switching capacity (resistive load)	5A 277V AC
	Max. switching power (resistive load)	1,385VA
	Max. switching voltage	277V AC
	Max. switching current	5A
	Max. switching capacity (reference value)	100mA 5V DC

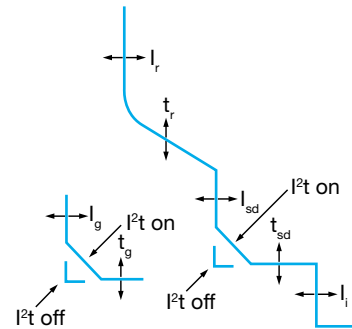

Protection

Protection Type	Parameter	Setting	In = Ictx...											
			0.5	0.63	0.7	0.8	0.9	1						
Long time LTD	current setting (A)	I _r = I _{nx} ...	0.8	0.83	0.85	0.88	0.9	0.93	0.95	0.98	1	Non		
	time delay(sec) accuracy: ±15% or below 100ms	tr at(1.5×I _r)	10.4	26.1	41.7	52	104	208	312	417	521	626		
		tr at(6.0×I _r)	0.5	1.25	2	2.5	5	10	15	20	25	30		
		tr at(7.2×I _r)	0.35	0.86	1.38	1.73	3.45	6.9	10.4	13.8	17.3	20.7		
Short time STD	current setting(A) accuracy: ±15%	I _{sd} = I _{nx} ...	1	1.5	2	2.5	3	4	6	8	10	Non		
		time delay (sec) at 10×I _n	tsd	I ² t off	0.05	0.1	0.2	0.3	0.4	0.5				
	I ² t on		0.05	0.1	0.2	0.3	0.4	0.5						
	(I ² t off)	min. trip time (ms)	20	80	160	260	360	460						
max. trip time (ms)		80	140	240	340	440	540							
Instantaneous INST	current setting (A) accuracy ±10%	I _{li} = I _{nx} ...	2	3	4	6	8	10	12	15	Non			
	trip time		below 50ms											
Ground fault GFT	current setting (A) accuracy: ±20%(I _g >0.4I _n) ±20%(I _g ≤0.4I _n)	I _g = I _{ctx} ...	0.1	0.2	0.3	0.4	0.5	0.6	0.7	0.8	1	Non		
		time delay (sec) at 1×I _n accuracy: ±20%	tg	I ² t off	0.05	0.1	0.2	0.3	0.4	0.5				
	I ² t on		0.05	0.1	0.2	0.3	0.4	0.5						
	(I ² t off)	min. trip time (ms)	20	80	160	260	360	460						
max. trip time (ms)		80	140	240	340	440	540							

Basic OCR

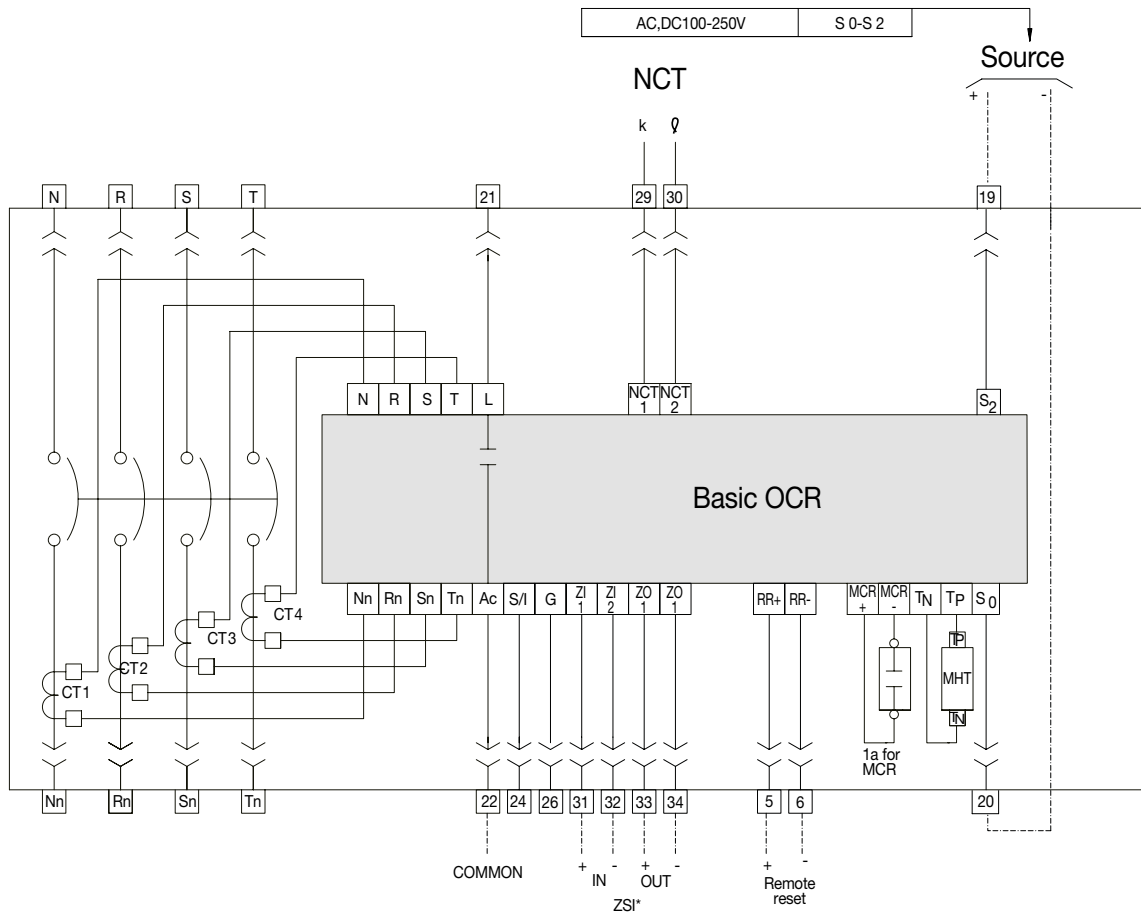

* ZSI: contacts 31-32 are pre-wired by factory. If you use ZSI function, please remove this wire.

Amp type OCR: HWX621, HWX622, HWX623



- Overload protection
 - Long time delay
 - Thermal function
- Short circuit protection
 - Short time delay, instantaneous trip
 - I²t on/off optional (for STD)
- Neutral wire protection
 - 3 Pole: No protection
 - 4 Pole: Non, 50%, 100% (x I_e, I_{sd}, I_i)
- Measurement and display
 - 3 phase current
- Realization of protective coordination by ZSI (zone selective interlocking)
- Fault recording
 - Record up to 256 fault information about fault type, fault phase, fault value, occurrence time of fault.
 - Record latest fault waveform (4 period, check by communication)
- Event recording
 - Record events of device related to setting change, operation and state change up to 200
- Pre-trip alarm
 - Prevent unnecessary over load trip according to rated current (I_n)
- Field test
 - Simulation of long time, short time, instantaneous delay
- Communication : RS-485 / MODBUS-RTU

- 4 digital output NO
- Contact specification

Rating	Nominal switching capacity (resistive load)	5A 277V AC
	Max. switching power (resistive load)	1,385VA
	Max. switching voltage	277V AC
	Max. switching current	5A
	Max. switching capacity (reference value)	100mA 5V DC

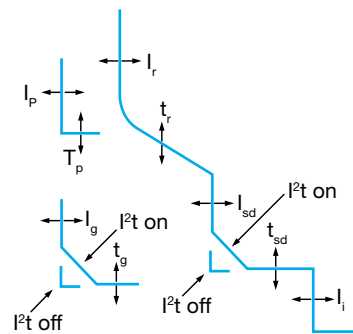

Protection

Protection Type	Parameter	Setting	In=Ictx...											
			0.5	0.63	0.7	0.8	0.9	1						
Long time LTD	current setting (A)	I _r =I _n x...	0.8	0.83	0.85	0.88	0.9	0.93	0.95	0.98	1	Non		
	time delay (sec) accuracy: ±15% or below 100ms	tr at(1.5xI _r)	10.4	26.1	41.7	52	104	208	312	417	521	626		
		tr at(6.0xI _r)	0.5	1.25	2	2.5	5	10	15	20	25	30		
		tr at(7.2xI _r)	0.35	0.86	1.38	1.73	3.45	6.9	10.4	13.8	17.3	20.7		
Short time STD	current setting (A) accuracy: ±15%	I _{sd} =I _n x...	1	1.5	2	2.5	3	4	6	8	10	Non		
		time delay (sec) at 10xI _n	I ² t off	I ² t off	0.05	0.1	0.2	0.3	0.4	0.5				
	I ² t on			0.05	0.1	0.2	0.3	0.4	0.5					
	(I ² t off)	min. trip time (ms)	20	80	160	260	360	460						
max. trip time (ms)		80	140	240	340	440	540							
Instantaneous INST	current setting (A) accuracy ±10%	I _i =I _n x...	2	3	4	6	8	10	12	15	Non			
	trip time		below 50ms											
Ground fault GFT	pick-up (A) accuracy: ±15%(I _g >0.4I _n) ±20%(I _g ≤0.4I _n)	I _g =I _{ct} x...	0.1	0.2	0.3	0.4	0.5	0.6	0.7	0.8	1	Non		
		time delay (sec) at 1xI _n accuracy: ±20%	I ² t off	I ² t off	0.05	0.1	0.2	0.3	0.4	0.5				
	I ² t on			0.05	0.1	0.2	0.3	0.4	0.5					
	(I ² t off)	min. trip time (ms)	20	80	160	260	360	460						
max. trip time (ms)		80	140	240	340	440	540							
Pre trip alarm PTA	current setting (A) accuracy: ±15%	I _p =I _n x...	0.6	0.65	0.7	0.75	0.8	0.85	0.9	0.95	1	Non		
	time delay (sec)	t _p at (I _p x1.2)	5	10	15	20	40	60	80	120	160			

Amp type OCR

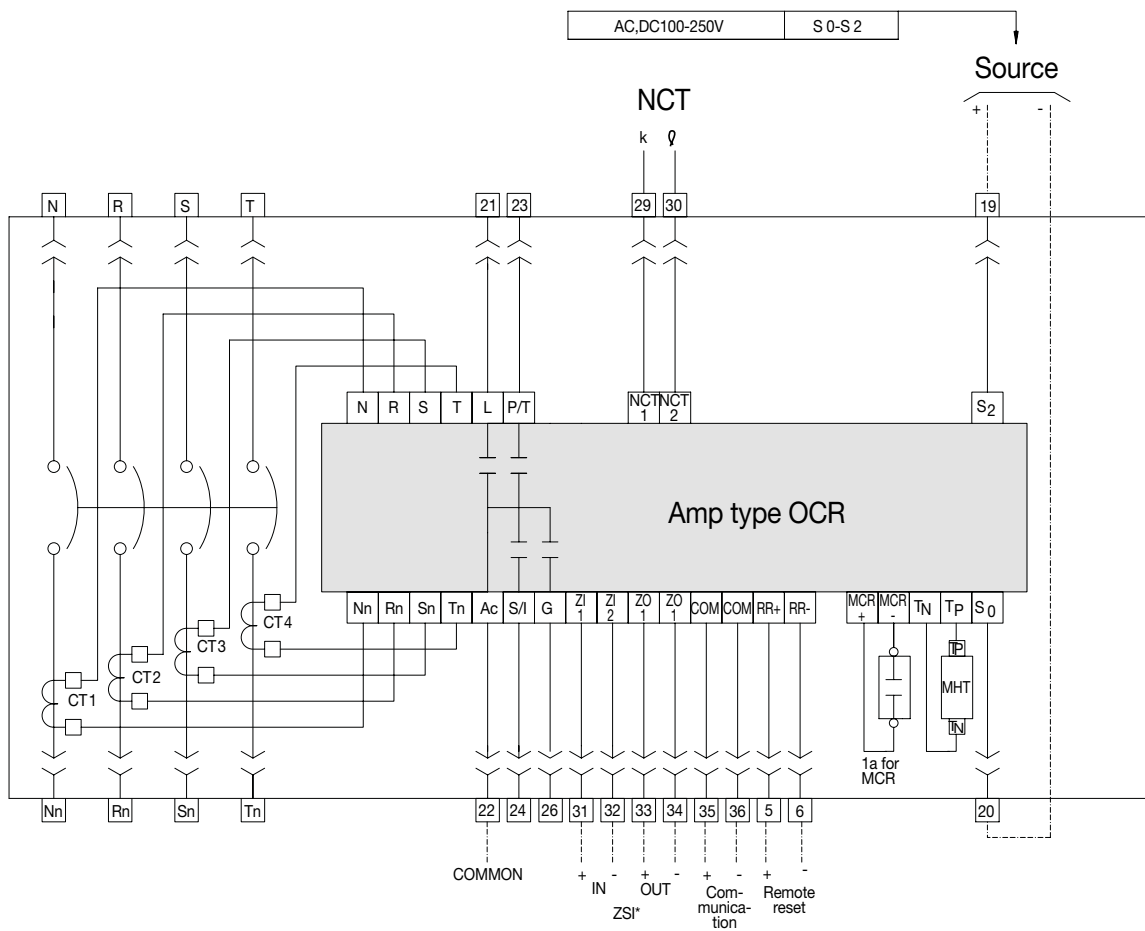

* ZSI: contacts 31-32 are pre-wired by factory. If you use ZSI function, please remove this wire.

Energy type OCR: HWX633



- Overload protection
 - Long time delay
 - Thermal function
- Short circuit protection
 - Short time delay, instantaneous trip
 - I²t on/off optional (for STD)
- Ground fault protection
 - I²t on/off optional (for GFT)
 Neutral wire protection
 - 3 Pole: No protection
 - 4 Pole: Non, 50%, 100% (x I_r, I_{sd}, I_i)
- Overload/underload/voltage imbalance protection
- Measurement and display
 - 3 phase current/Voltage/Power/Power factor/energy/phase/demand
- Realization of protective coordination by ZSI (zone selective interlocking)
- Fault recording
 - Record up to 256 fault information about fault type, fault phase, fault value, occurrence time of fault.
 - Record latest fault waveform (4 period, check by communication)
- Event recording
 - Record events of device related to setting change, operation and state change up to 200
- Pre-trip alarm
 - Prevent unnecessary over load trip according to rated current (I_n)
- Field test
 - Simulation of long time, short time, instantaneous delay

- Communication: RS-485 / MODBUS-RTU
- Must install voltage module
- 4 digital output - NO
 - Contact Specification

Rating	Nominal switching capacity (resistive load)	5A 277V AC
	Max. switching power (resistive load)	1,385VA
	Max. switching voltage	277V AC
	Max. switching current	5A
	Max. switching capacity (reference value)	100mA 5V DC

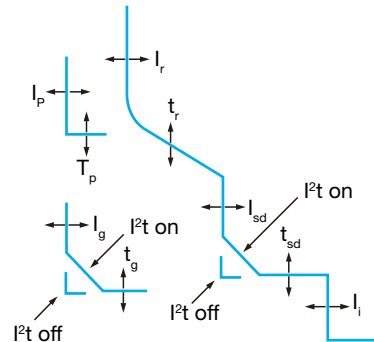

Protection

Protection Type	Setting	Formula	Rated Current (A)											
			0.5	0.63	0.7	0.8	0.9	1	1.1	1.25	1.5	2	Non	
Long time LTD	current setting (A)	I _n =I _{ct} ×...	0.5	0.63	0.7	0.8	0.9	1						
	time delay (sec) accuracy: ±15% or below 100ms	tr at(1.5×I _r)	10.4	26.1	41.7	52	104	208	312	417	521	626		
		tr at(6.0×I _r)	0.5	1.25	2	2.5	5	10	15	20	25	30		
		tr at(7.2×I _r)	0.35	0.86	1.38	1.73	3.45	6.9	10.4	13.8	17.3	20.7		
Short time STD	current setting (A) accuracy: ±15%	I _{sd} =I _n ×...	1	1.5	2	2.5	3	4	6	8	10	Non		
	time delay (sec) at 10×I _n	I ² t off	0.05	0.1	0.2	0.3	0.4	0.5						
		I ² t on	0.05	0.1	0.2	0.3	0.4	0.5						
	(I ² t off)	min. trip time (ms)	20	80	160	260	360	460						
max. trip time (ms)		80	140	240	340	440	540							
Instantaneous INST	current setting (A) accuracy ±10%	I _i =I _n ×...	2	3	4	6	8	10	12	15	Non			
	trip time		below 50ms											
Ground fault GFT	pick-up (A) accuracy: ±15%(I _g >0.4I _n) ±20%(I _g ≤0.4I _n)	I _g =I _{ct} ×...	0.1	0.2	0.3	0.4	0.5	0.6	0.7	0.8	1	Non		
	time delay (sec) at 1×I _n accuracy: ±20%	I ² t off	0.05	0.1	0.2	0.3	0.4	0.5						
		I ² t on	0.05	0.1	0.2	0.3	0.4	0.5						
	(I ² t off)	min. trip time (ms)	20	80	160	260	360	460						
max. trip time (ms)		80	140	240	340	440	540							
Pre trip alarm PTA	current setting (A) accuracy: ±15%	I _p =I _n ×...	0.6	0.65	0.7	0.75	0.8	0.85	0.9	0.95	1	Non		
	time delay (sec)	t _p at (I _p ×1.2)	5	10	15	20	40	60	80	120	160			

Energy type OCR

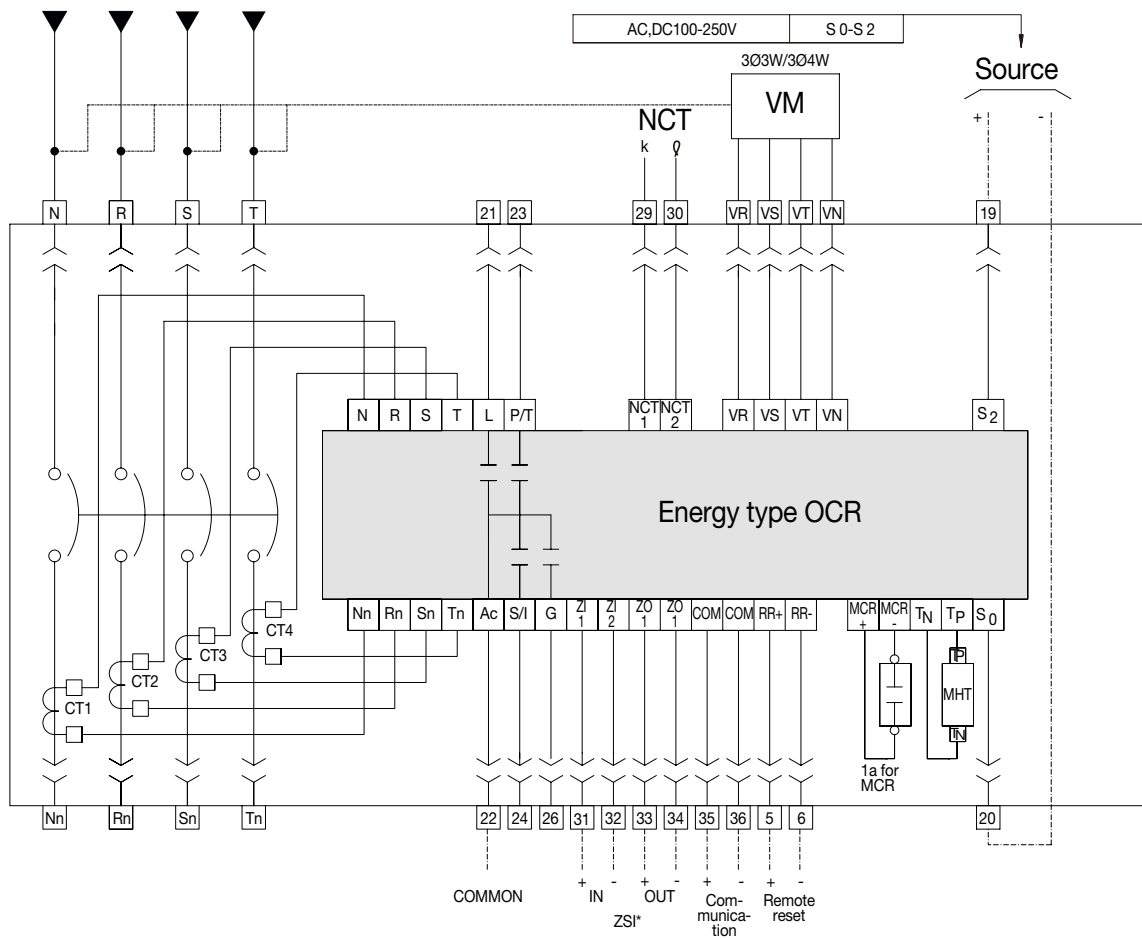

* ZSI: contacts 31-32 are pre-wired by factory. If you use ZSI function, please remove this wire.

Values of I_{ct} and I_n

Frame	Applicable	Rated current (I_n)					
		I_{ct} (max)					
		I_n (A)	x0.5	x0.63	x0.7	x0.8	x0.9
A	630	315	397	441	504	567	630
	800	400	504	560	640	720	800
	1000	500	630	700	800	900	1000
	1250	625	787	875	1000	1125	1250
	1600	800	1008	1120	1280	1440	1600
	2000	1000	1260	1400	1600	1800	2000
B	630	315	397	441	504	567	630
	800	400	504	560	640	720	800
	1000	500	630	700	800	900	1000
	1250	625	787	875	1000	1125	1250
	1600	800	1008	1120	1280	1440	1600
	2000	1000	1260	1400	1600	1800	2000
	2500	1250	1575	1750	2000	2250	2500
	3200	1600	2016	2240	2560	2880	3200
C	3200	1600	2016	2240	2560	2880	3200
	4000	2000	2520	2800	3200	3600	4000
	5000	2500	3150	3500	4000	4500	5000

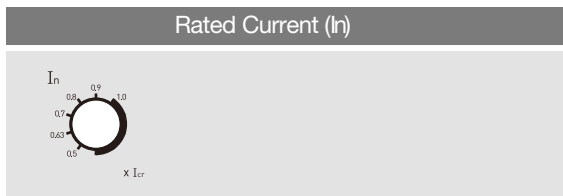

- Rated current [I_n] can be adjusted to 50%, 63%, 70%, 80%, 90% and 100% of the rated primary CT current [I_{ct}].
- On the ACB nameplate, rated current [I_n] is marked.
- Rated current [I_n] can be selected by sliding the base current setting select switch, which can be set to the predetermined scale.

Operation characteristics

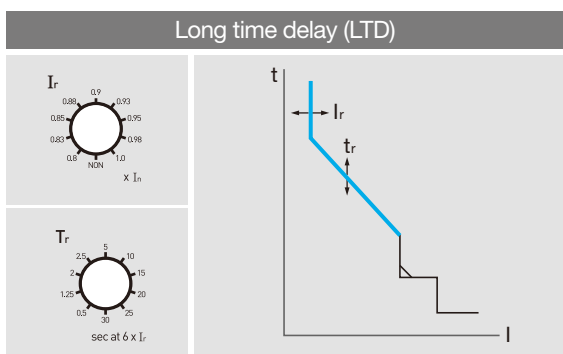

Standard current setting

- The scale is marked as magnification of [I_n].
- Setting range: (Non, 0.8, 0.83, 0.85, 0.88, 0.9, 0.93, 0.95, 0.98, 1.0) x I_n (10 modes)
- No protection in case of non setting of [I_r].
- The breaker is not tripped below 105% of [I_r], and tripped at 120%.

Time delay setting

- Standard operating time (sec) is based on the time of 600% x [I_r] with inverse time operation.
- Setting range: 0.5, 1.25, 2, 2.5, 5, 10, 15, 20, 25, 30sec (10 modes)
- The breaker is tripped at $\pm 15\%$ of setting time.

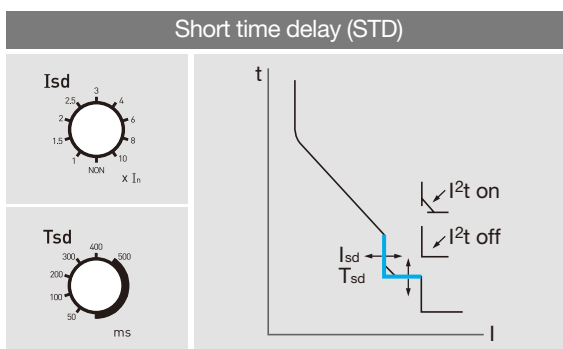

Standard current setting

- The scale is marked as magnification of [I_n].
- Setting range: (Non, 1, 1.5, 2, 2.5, 3, 4, 6, 8, 10) x I_n (10 modes)

Time delay setting

- Standard operating time (msec) is based on the time of 120% x [I_{sd}] with definite time operation.
- Setting range: 50, 100, 200, 300, 400, 500msec (6 modes)
- 100% of inverse time curve applied in case of inverse time (I^2t on) setting.

DIP switch

- I_{sd}^2t ON: for inverse time characteristic, which has $I_{sd}^2t=C$ (constant) characteristic at 100% of a set point, tolerance of setting current is $\pm 20\%$
- I_{sd}^2t OFF: for definite time characteristics

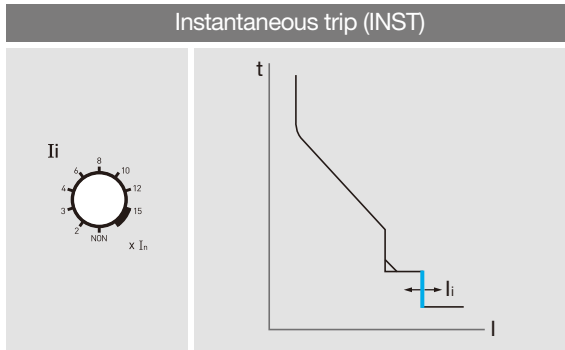

Standard current setting

- The scale is marked as magnification of [Ict].
- Setting range: (Non, 2, 3, 4, 6, 8, 10, 12, 15) × In (9 modes)
- No protection in case of non setting of [Ii].

Time delay setting

- Total breaking time is below 50ms.

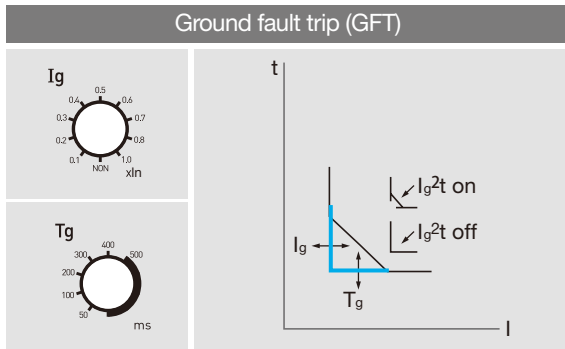

Standard current setting

- The scale is marked as magnification of OCR rated primary current [Ict].
- Setting range: (Non, 0.1, 0.2, 0.3, 0.4, 0.5, 0.6, 0.7, 0.8, 1.0) × [Ict] (10 steps)

Time delay setting

- Standard operating time (msec) is based on the time of 120% × [Ig] with definite time operation.
- Setting range: 50, 100, 200, 300, 400, 500msec (6 steps)
- Inverse time operated with 100% of [Ict] standard in case of [I2t on] setting.

DIP switch

- Ig²t ON: for inverse time characteristic, which has Ig²t=C (constant) characteristic at 100% of a set point, tolerance of setting current is ±30%
- Ig²t OFF: for definite time characteristics

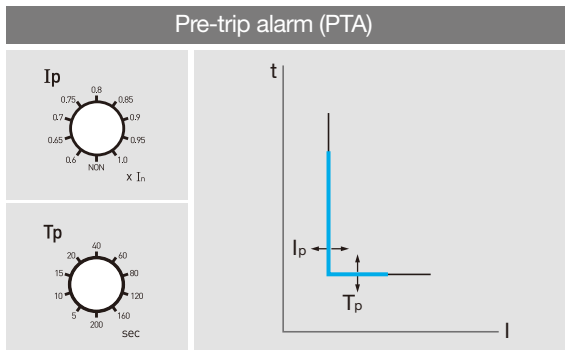

Standard current setting

- The scale is marked as magnification of [In] with definite time operation.
- Setting range: (Non, 0.6, 0.65, 0.7, 0.75, 0.8, 0.85, 0.9, 0.95, 1.0) × In (10 steps)

Time delay setting

- Standard operating time (sec) is based on the time of 100% × [Ip].
- Setting range: 5, 10, 15, 20, 40, 60, 80, 120, 160, 200sec (10 steps).

Additional voltage measurement factor (Energy type)

Type		Threshold		Time delay		
		range	step	range	step	accuracy
Minimum voltage Umin	pickup	100V ~ Umax	5V	1.2s ~ 5s	0.1s	20%
	dropout	pickup ~ Umax	5V	1.2s ~ 36s	0.1s	-20%
Maximum voltage Umax	pickup	Umin pickup ~ 800V	5V	1.2s ~ 5s	0.1s	20%
	dropout	100V ~ pickup	5V	1.2s ~ 36s	0.1s	-20%
U unbal	pickup	2 ~ 30%	1%	1s ~ 40s	1s	-20%
	dropout	2 ~ pickup	50kW	10s ~ 360s	1s	-20%

- Operate Alarm contact (22, 23) without tripping ACB.

Reverse power (Energy type)

Type		Threshold		Time delay		
		range	step	range	step	accuracy
Reverse power rPmax	pickup	5 ~ 500kW	5kW	0.2s ~ 20s	0.1s	20%
	dropout	5kW ~ pickup	5kW	1s ~ 360s	0.1s	20%

- Operate alarm contact (22, 23) without tripping ACB.

- Depending on the total active power value, operates when current direction is opposite from the power direction user specified.

- + direction : Current flow from above to below ACB terminal (default).
- direction : Current flow from below to above ACB terminal.

Zone selective interlock function (ZSI)

Zone selective interlocking drops delay time that eliminates faults for breakers. It minimizes the shock that all kinds of electric machinery get under fault conditions.

Example

- In case of that short time-delay or ground fault accident occurs at ZSI built in system, the breaker at accident site sends ZSI signal to halt upstream breaker's operation.
- To eliminate a breakdown, trip relay of ACB at accident site activates trip operation without time delay.
- The upstream breaker that received ZSI signal adhere to pre-set short time-delay or ground fault time delay for protective coordination in the system. However upstream breaker that did not receive its signal will trip instantaneously.
- For ordinary ZSI operation, it should arrange operation time accordingly so that downstream circuit breakers will react before upstream ones under overcurrent/short time delay/ground fault situations.

ZSI conditions

Type of ZSI	Number of ACBs (in total)	Max. distance between 2 ACBs
In series	2	100 m
	6	10 m
In parallel	6	10 m

Twisted shield cable (AWG 16-22) maximum impedance: 3Ω

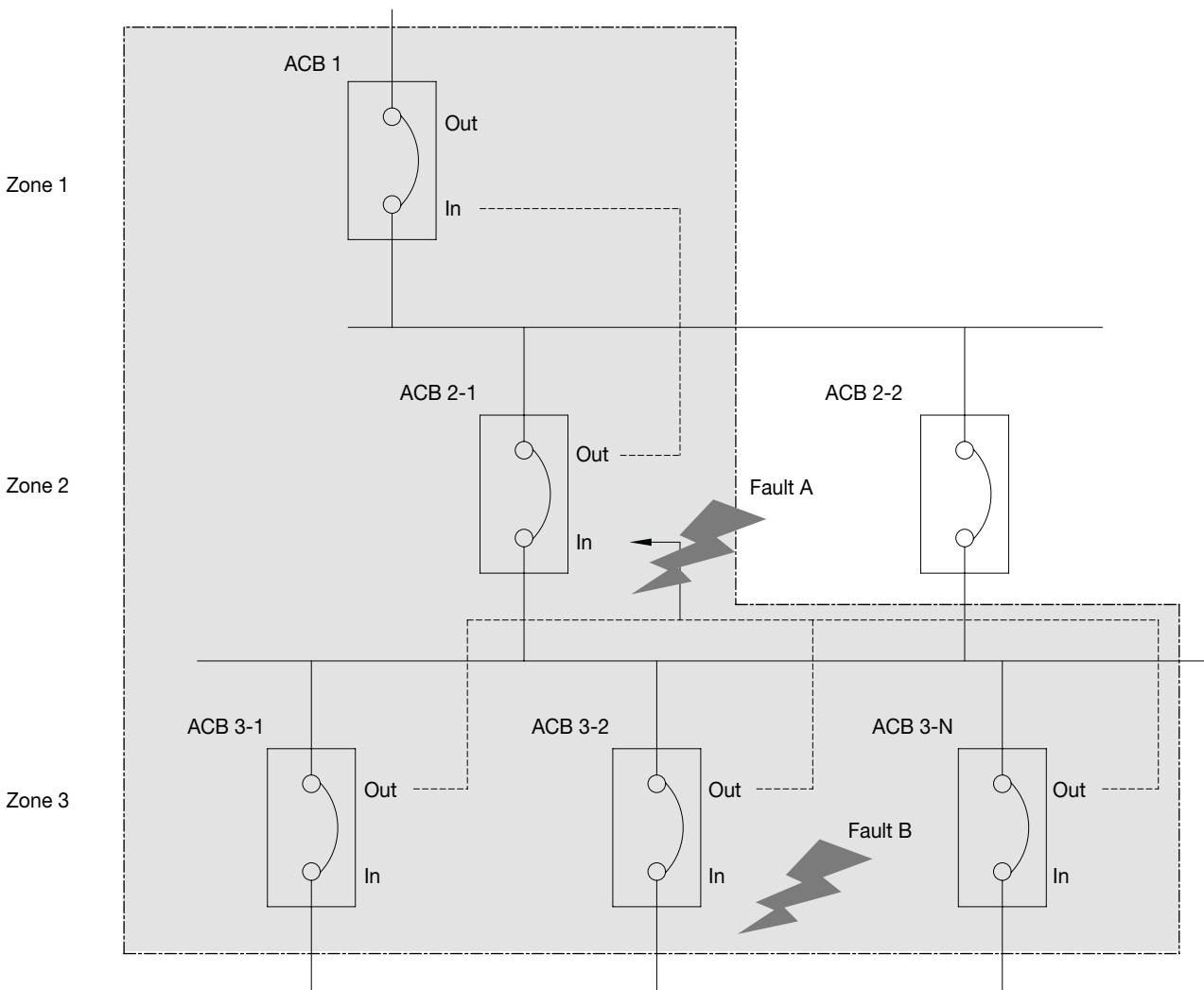

----- ZSI connecting

Pre-wired contact (31,32) as standard by factory.
If you use ZSI function between 2 breakers, please use this wire.

General feeder

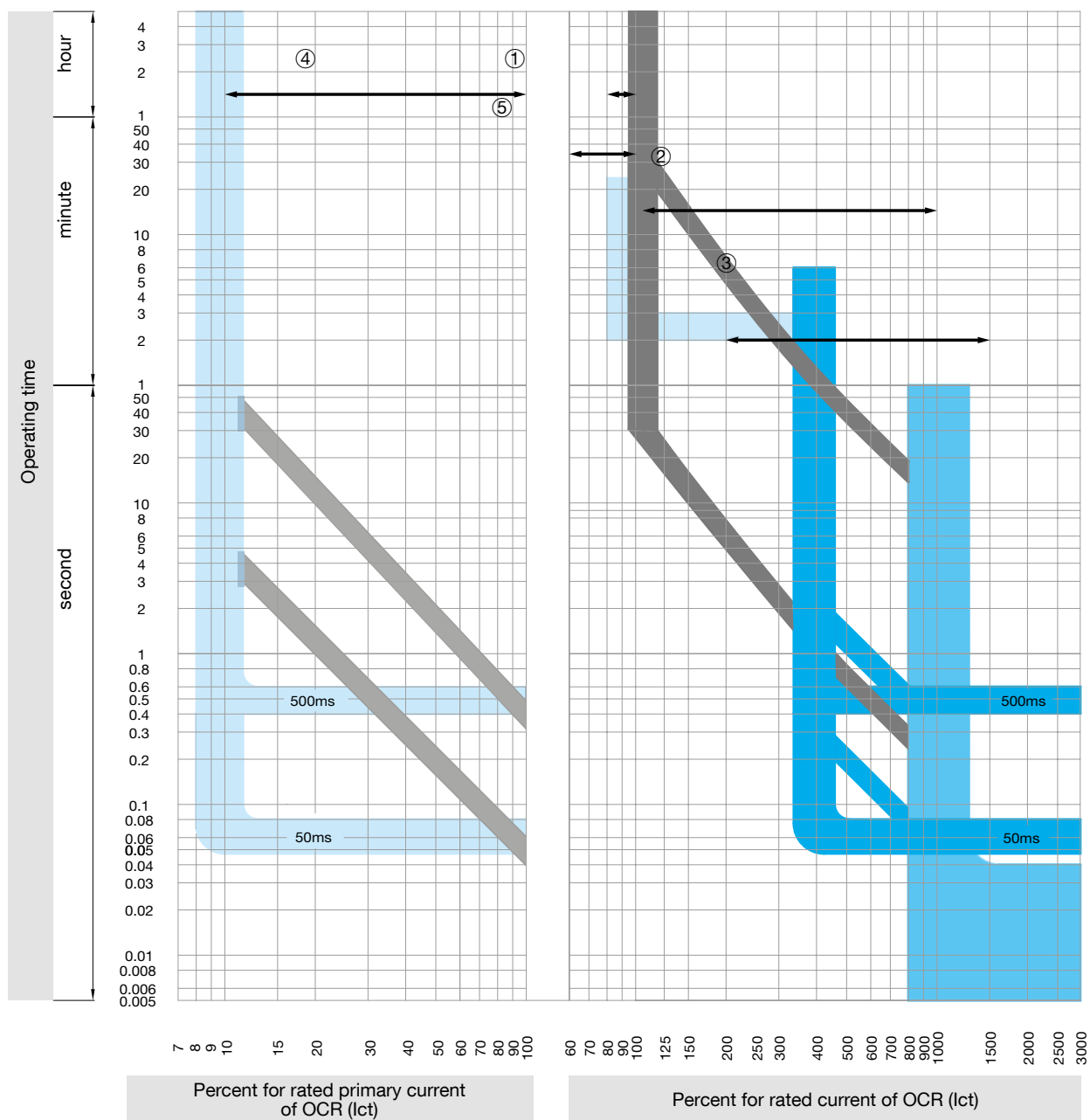

- ① Long time delay current setting range LTD
- ② Short time delay current setting range STD
- ③ Instantaneous tripping current setting range INST
- ④ Ground fault trip current setting range GFT
- ⑤ Pre-trip alarm current setting range PTA

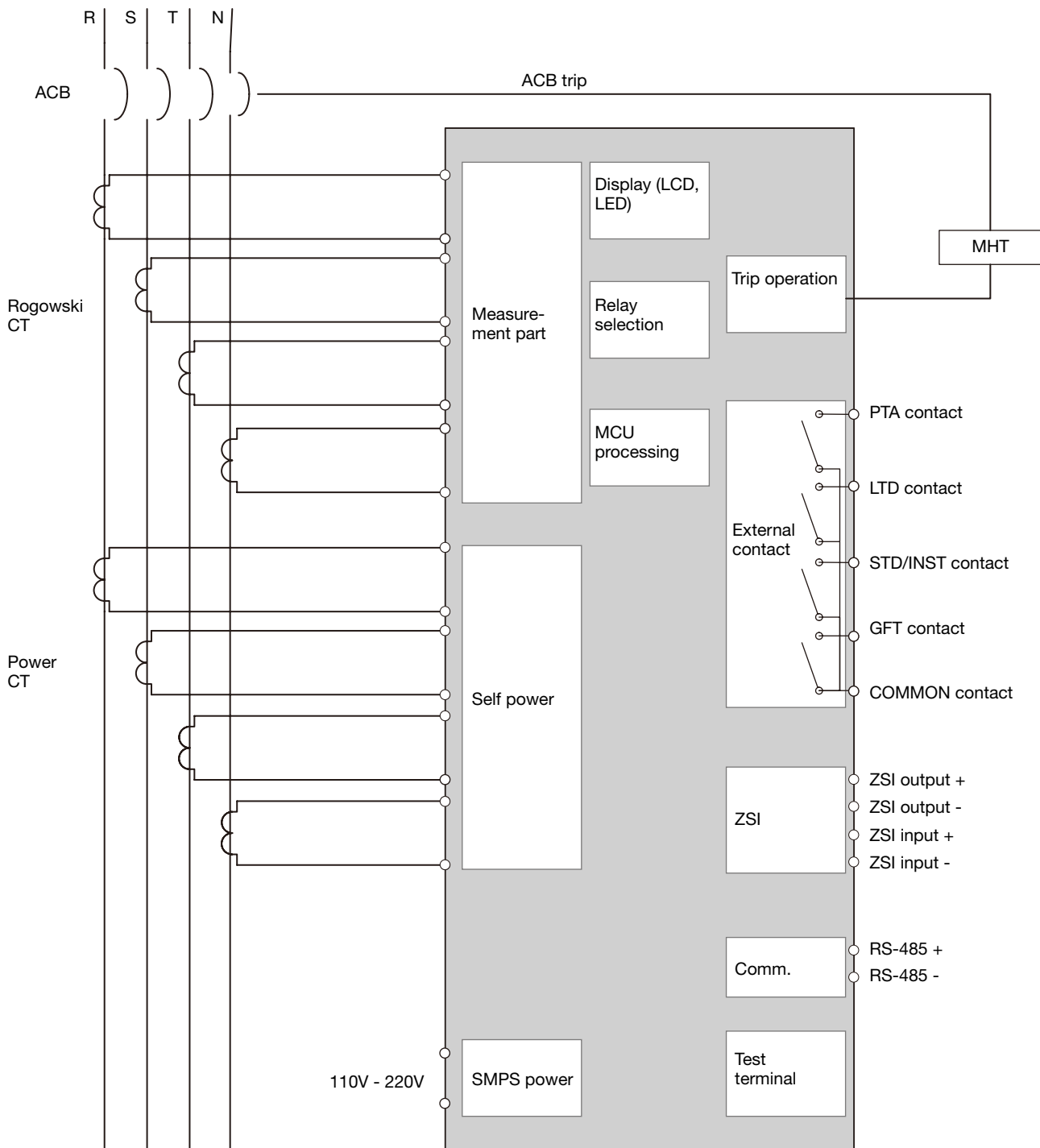

The ACB HW series OCR Amp and Energy types are equipped with communication module.

It allows to get all breakers information from network at any location connected to the bus, such as:

- measurements: current, voltage, power, power factor, energy, frequency
- breaker status: closing, opening and other state
- fault recording: time-stamped trip information
- event logging
- protect the controller setting
- protect pre-alarm controller

In addition to the Voltage Module HWY650 and Remote Control Unit HWY639, the user can control the breaker for the following operations: opening, closing, and reset.

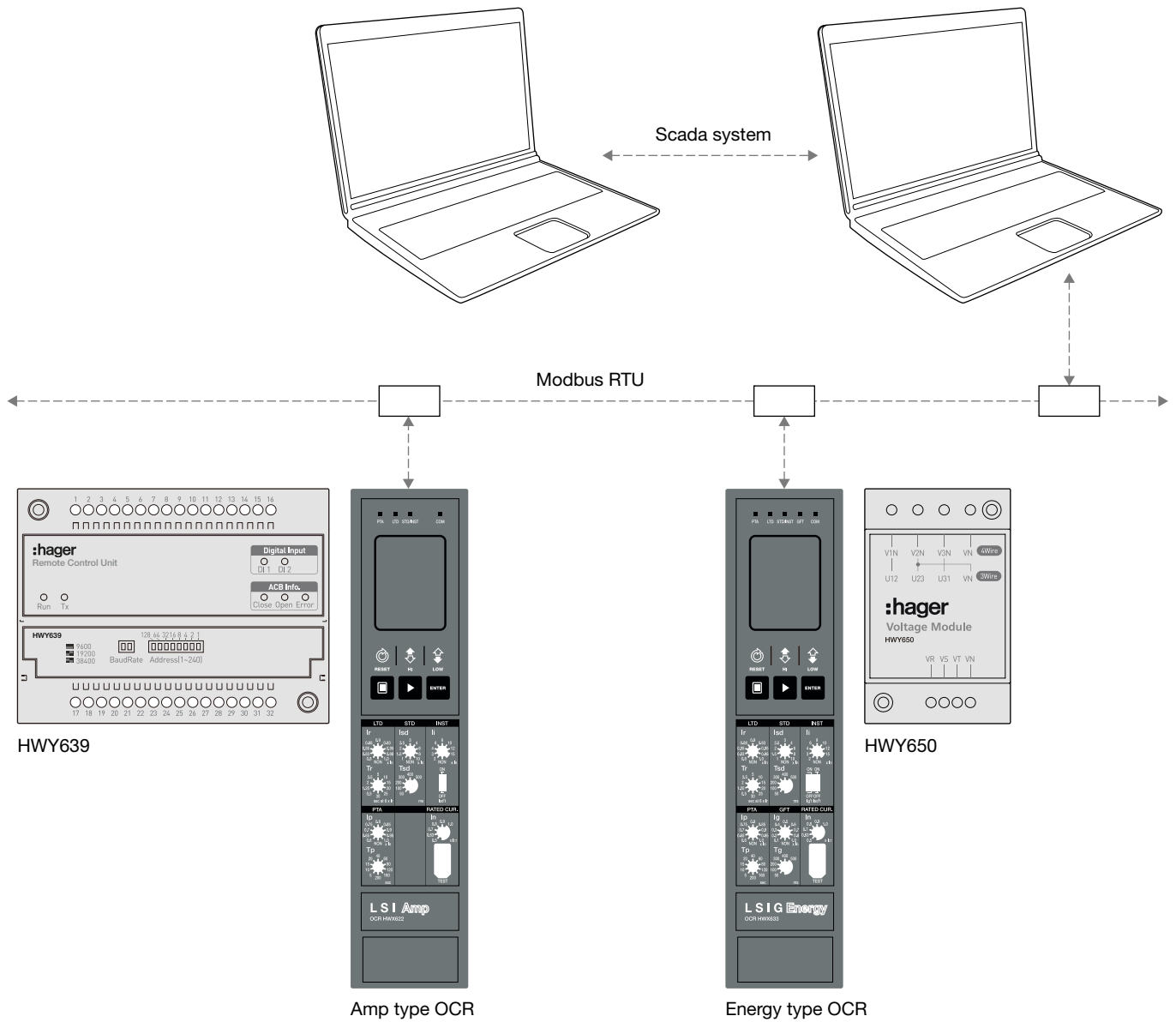

Characteristics

- operation mode: differential
- max. distance: 1.2 km
- baud rate: 9600 · 19200 · 38400 bps
- transmission method: half-duplex
- termination: 150Ω

Remote control temperature unit (RCTU) and remote control unit (RCU)

- RCTU has Digital Output contact that ables to insert/disconnect ACB remotely by communication. It checkes temperature of ACB with 4 temperature channel.
- RCTU communication offers RS-485/Modbus-RTU.
- Insert/ disconnect control of ACB assures its reliability through SBO (select before operation) function.
- If the temperature rises over the user setting value, you can check it through alarm contacting point (additional connection needed).
- You can check ACB temperature through segment LED at the front.
- RCTU can be installed in side the ACB cradle or panle.
- RCU module same function with RCTU module except temperat- ure monitoring.

Contact specification

Type		Range of application
ACB control	contact ratings	10A 240VAC, 30VDC
	max. switching power	2400VA, 300W
Temperature alarm	contact ratings	10A 240VAC/5A 240VAC/5A 30VDC
	max. switching power	1200VA, 150W

Remote control temperature unit (RCTU)

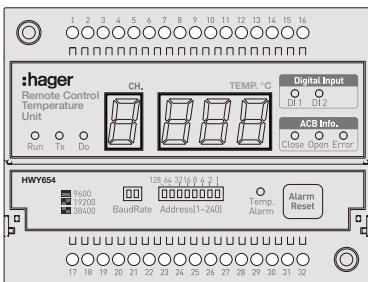

Remote control unit (RCU)

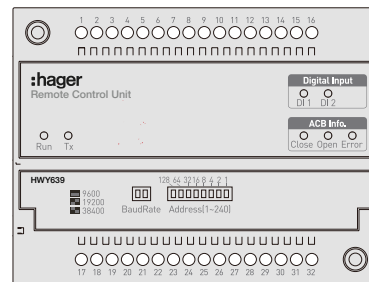

RCTU terminal composition

No.	Definition	No.	Definition
1	DI CB CONNECT	17	NTC Temperature sensor
2	DI CB CONNECT	18	NTC Temperature sensor
3	DI CB TEST	19	CH3 infrared light sensor AOR (white)
4	DI CB TEST	20	CH3 infrared light sensor GND (green)
5	DI CLOSE	21	CH3 infrared light sensor AOT (yellow)
6	DI CLOSE	22	CH3 infrared light sensor power (red)
7	DI OPEN	23	CH3 infrared light sensor AOR (white)
8	DI OPEN	24	CH3 infrared light sensor GND (green)
9	DO TEMP. ALARM	25	CH3 infrared light sensor AOT (yellow)
10	DO TEMP. ALARM	26	CH3 infrared light sensor power (red)
11	DO CLOSE	27	CH3 infrared light sensor AOR (white)
12	DO CLOSE	28	CH3 infrared light sensor GND (green)
13	DO OPEN	29	CH3 infrared light sensor AOT (yellow)
14	DO OPEN	30	CH3 infrared light sensor power (red)
15	AC/DC Power	31	RS485 (-)
16	AC/DC Power	32	RS485 (+)

RCU terminal composition

No.	Definition	No.	Definition
1	DI CB CONNECT	17	-
2	DI CB CONNECT	18	-
3	DI CB TEST	19	-
4	DI CB TEST	20	-
5	DI CLOSE	21	-
6	DI CLOSE	22	-
7	DI OPEN	23	-
8	DI OPEN	24	-
9	-	25	-
10	-	26	-
11	DO CLOSE	27	-
12	DO CLOSE	28	-
13	DO OPEN	29	-
14	DO OPEN	30	-
15	AC/DC Power	31	RS485 (-)
16	AC/DC Power	32	RS485 (+)

Shape

Status LED		Information
RCTU	Run LED	RCTU running LED
	Com LED	communication LED
	Temp. Alarm LED	temp. alarm LED
	Alarm DO LED	temp. alarm DO LED
General digital input	D11	dry contact (5V)
	D12	dry contact (5V)
ACB control	Close	ACB close LED
	Open	ACB open LED
	Error	ACB close/open terminal disconnection and controlling error

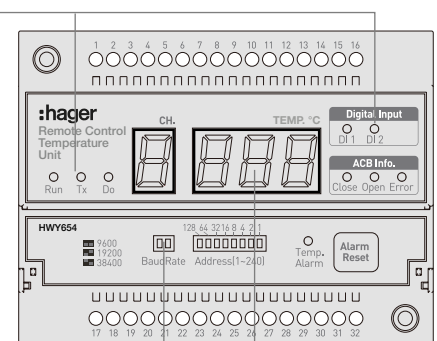

Communication setting

Temperature indicator

HWY650

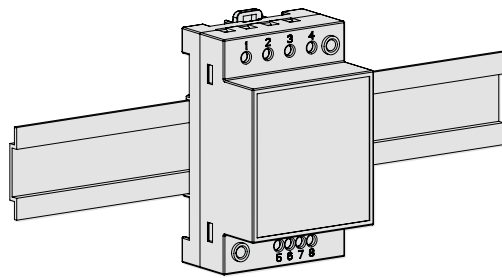

Dimensions (mm)

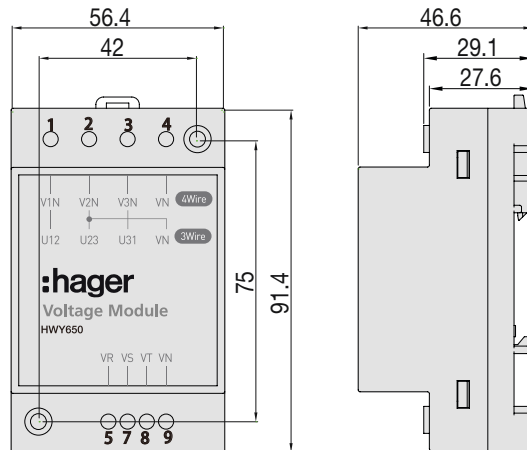

Voltage connection

Trip unit offers VM (Voltage module) as an essential option, to measure voltage.
Voltage input range: AC 69 ~ 690V

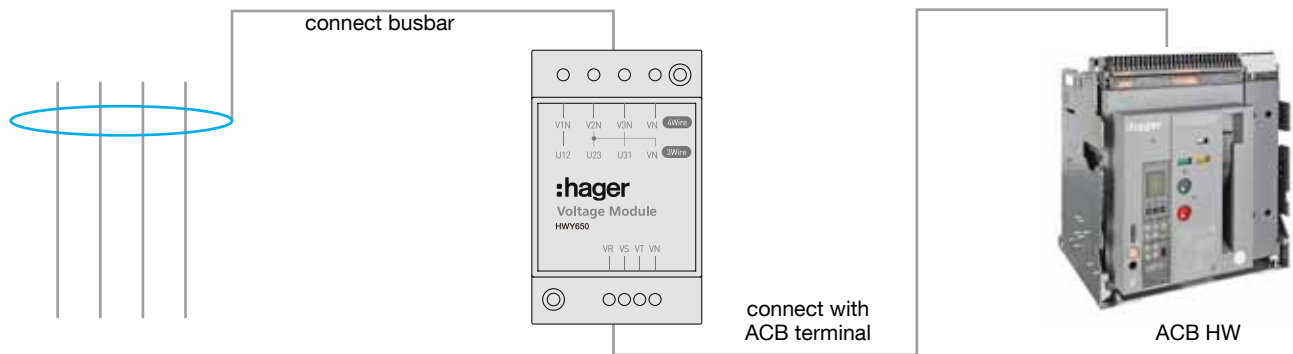

3 pole 3 wire

(L1)(L2)(L3)
R S T

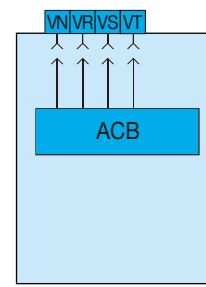
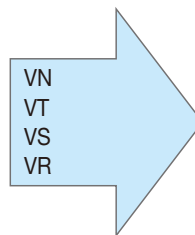
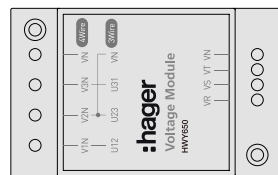
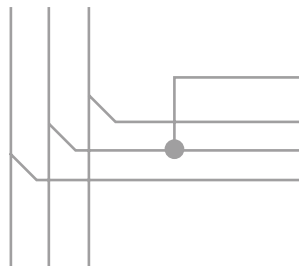

ACB terminal

4 pole 4 wire / 3 pole 4 wire

(L1)(L2)(L3)
R S T N

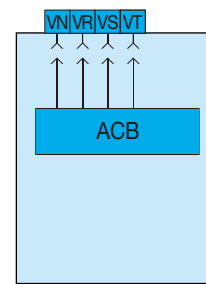
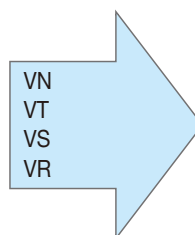
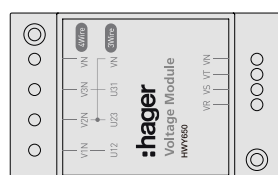
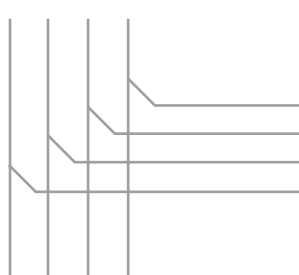

ACB terminal

Motor (MO)

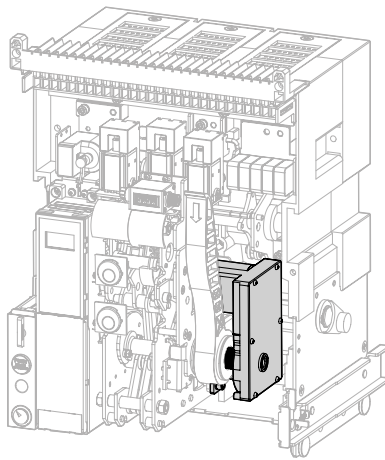
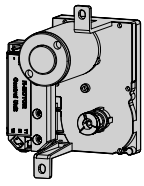

Connection diagram

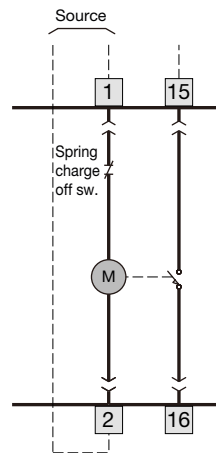

- Manual charging method and geared motor charging by external power source.
- Operating voltage range: 85-110%

Ratings

Rated voltage		
	DC110V	DC220V
rated current (A)	1.5	0.5
starting pick up(A)	5-6 times of rated current	
charging time (s)	within 5 sec ¹⁾	
torque (kgf)	300kgf×cm	
rated watt (W)	100	100
insulation voltage (V/min)	2,000	
insulation resistance (MΩ)	100	
ambient temperature (°C)	-15 to 60	

¹⁾ Charging time is within 10sec of rated, in case of DC24/48V.

Reference	Rating
HWX541	DC 24V
HWX542	DC 48V
HWX543	AC/DC 110V
HWX544	AC/DC 220V
HWX545	AC/DC 380/415V
HWX546	AC 440V

Wire ratings

Rated voltage			
DC 24/48V and AC/DC 110/220V		AC 380/440V	
AWG	insulation level (V)	AWG	insulation level (V)
20	300	20	600

Ready to close switch and spring charge

- These contacts (No.15,16) are for delivering spring charge status to outside and indicate the breaker is in a ready to close status.
- Optional device mounted on the body.

These contacts operate when the followings are valid:

- ACB is in OFF position
- spring charge indicator shows charged

- UVT is energised
- SH is not energised
- ACB is in connected position
- key lock is in open position (OFF)
- mechanical interlock is OFF

Closing coil (CC)

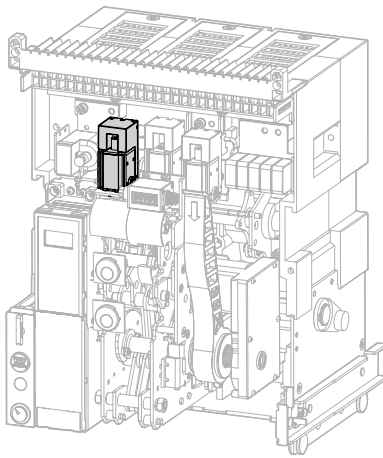
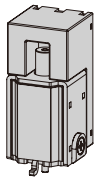

Connection diagram

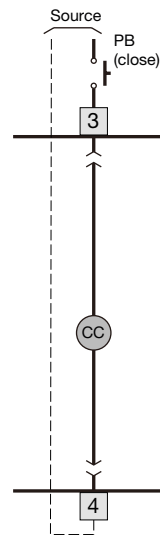

- A control device which closes a circuit breaker remotely, when applying 85-110% of rated control voltage over 150ms to coil terminals (3,4).

Ratings

Power supply (Vn)		operating limits	Power consumption (VA)		Opening time (ms)
DC (V)	AC (V)		inrush	steady-state	
24	-	0.85-1.1Vn	300	10	80
100-130	100-130	0.85-1.1Vn			
200-250	200-250	0.85-1.1Vn			

Reference	Rating
HWX551	DC 24V
HWX552	DC 48V
HWX553	AC/DC 110V
HWX554	AC/DC 220V
HWX555	AC/DC 380/415V
HWX556	AC 440V

Wire ratings

Rated voltage			
DC 24/48V and AC/DC 110/220V		AC 380/440V	
AWG	insulation level (V)	AWG	insulation level (V)
20	300	20	600

Shunt trip coil (SH)

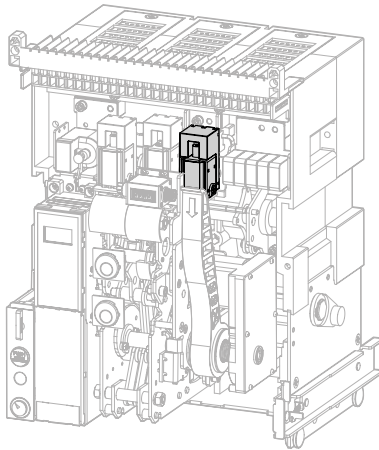
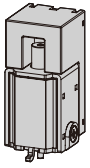

Connection diagram

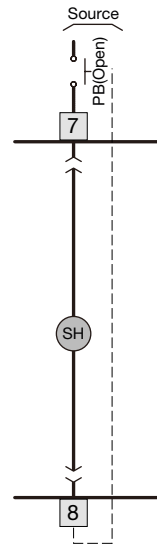

- A control device which trips a circuit breaker remotely, when applying 70-110% of rated control voltage over 150ms to coil terminals (7,8).

Ratings

Power supply (Vn)		Operating limits	Power consumption (VA)		Opening time (ms)
DC (V)	AC (V)		inrush	steady-state	
24	-	0.7-1.1Vn	300	10	50
100-130	100-130				
200-250	200-250				

Reference	Rating
HWX501	DC 24V
HWX502	DC 48V
HWX503	AC/DC 110V
HWX504	AC/DC 220V
HWX505	AC 380/415V
HWX506	AC 440V

Wire ratings

Rated voltage			
DC 24/48V and AC/DC 110/220V		AC 380/440V	
AWG	insulation level (V)	AWG	insulation level (V)
20	300	20	600

Second shunt trip coil (sSH)

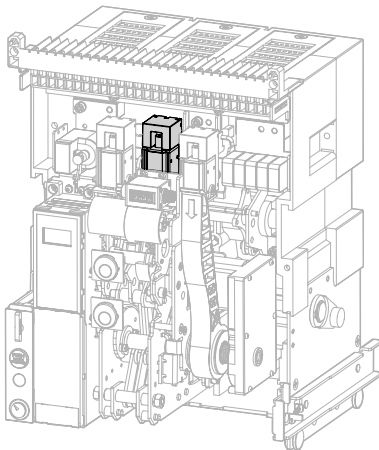
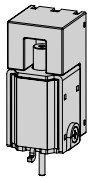

Connection diagram

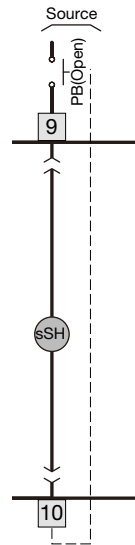

- A control device which trips a circuit breaker doubly from the outside.
- When second shunt trip coil is installed, there is no possibility to fit the UVT coil
- Rated control voltage range 70-110%, applying voltage over 150ms to coil terminals (9,10).

Ratings

Power supply (Vn)		Operating limits	Power consumption (VA)		Opening time (ms)
DC (V)	AC (V)		inrush	steady-state	
24	-	0.7-1.1Vn	300	10	50
100-130	100-130				
200-250	200-250				

Reference	Rating
HWX521	DC 24V
HWX522	DC 48V
HWX523	AC/DC 110V
HWX524	AC/DC 220V
HWX525	AC 380/415V
HWX526	AC 440V

Wire ratings

Rated voltage			
DC 24/48V and AC/DC 110/220V		AC 380/440V	
AWG	insulation level (V)	AWG	insulation level (V)
20	300	20	600

Under voltage trip coil (UVT)

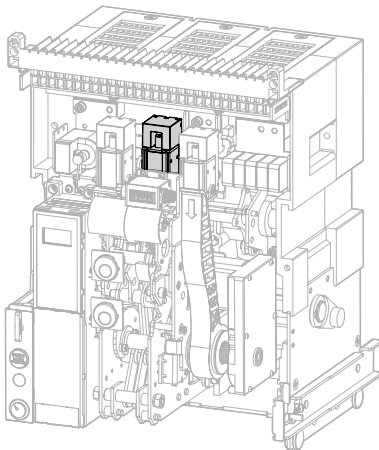
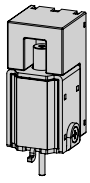

Connection diagram

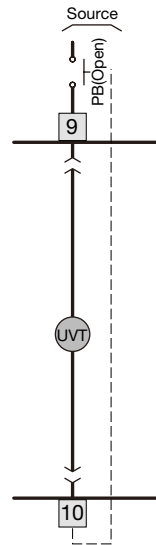

- If the voltage of the main or the control power is under 70% of the standard, UVT breaks the circuit automatically.
- Connect instantaneous type with both terminals (9,10) and connect with time delay type in order to present time delay controller.
 - The circuit breaker is opened with trip unit power supply voltages below 70%.
 - The circuit breaker is closed with unit power supply voltage above 85%.
- Instantaneous type can not be used with double trip coil.

Ratings

Power supply (Vn)		Pick-up	Drop	Power consumption (Vn)		Trip time (ms)
DC (V)	AC (V)			inrush	steady-state	
24	-	above 0.85Vn	below 0.35Vn	300	10	60
110 (100-130)	110 (100-130)					
200 (200-250)	200 (200-250)					
-	380					
-	440					

Reference	Rating
HWX511	DC 24V
HWX512	DC 48V
HWX513	AC/DC 110V
HWX514	AC/DC 220V
HWX515	AC 380/415V
HWX516	AC 440V

Wire ratings

Rated voltage			
DC 24/48V and AC/DC 110/220V		AC 380/440V	
AWG	insulation level (V)	AWG	insulation level (V)
20	300	20	600

UVT time delay controller

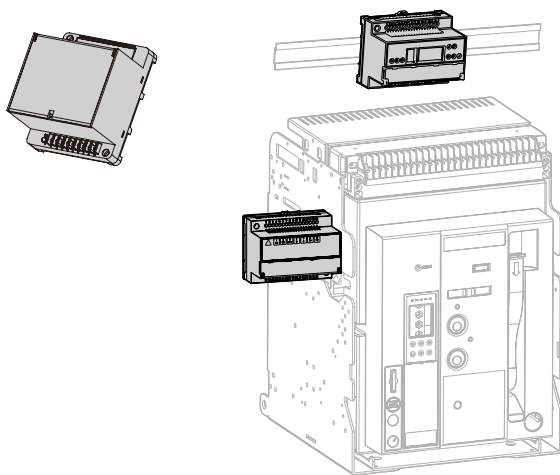

- This device is possible to delay as (0.5, 1.0, 1.5, 3 sec).
- It can be mounted at the left side of chassis or on the DIN rail.

Connection diagram

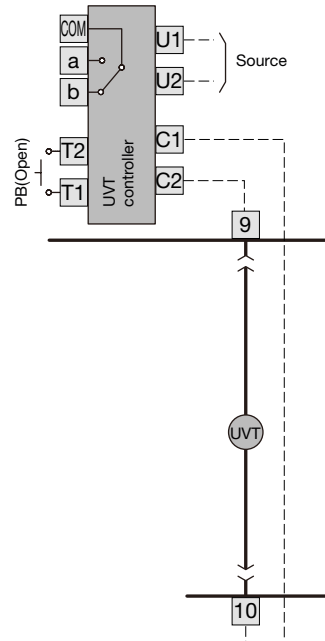

Connection and operating time

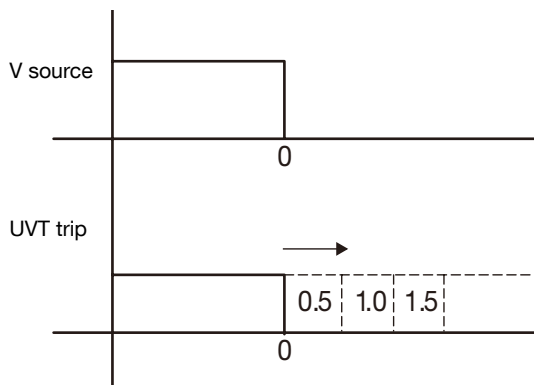

Dimensions (mm)

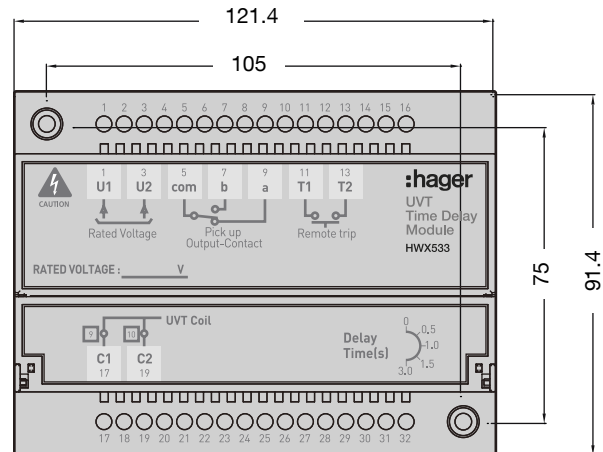

Ratings

Reference	Rating
HWX533	AC/DC 110V
HWX534	AC/DC 220V
HWX535	AC 380/415V
HWX536	AC 440V

Auxiliary switch

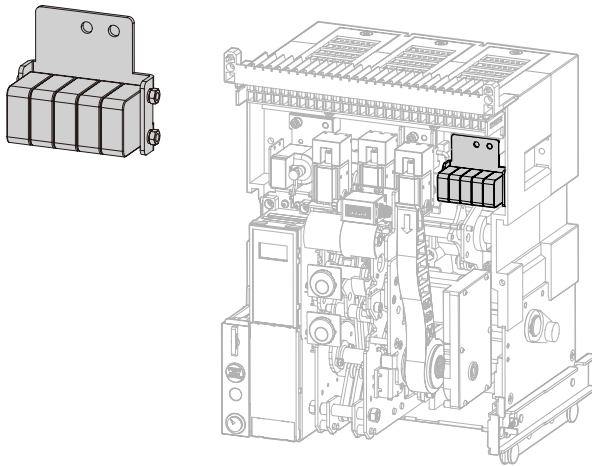

Connection diagram

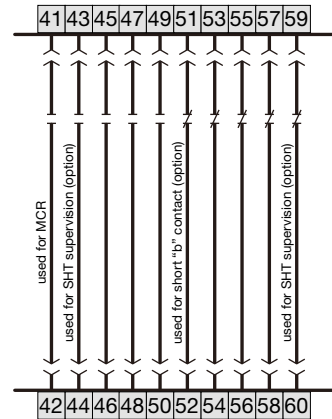

- A contact to monitor On/Off position of ACB remotely.
- 5a5b is standard for ACB HW series.
- Applicable AUX switch is up to 6a6b.
- When working with OCR's MCR function it will be 4NO, 5NC (4a5b). When both monitoring contact and MCR function working together it will be 3a4b.
- When ordering short "b" additionally it will be attached to 'b' contacts 51, 52 when the product is out. The additional short b which enclosed in the product is applicable as the number of the b contact.
- Additional 5a5b (MOC) can be fitted on the left side of breaker HW565.

Ratings

Load	Resistance	Lamp	Inductor	Motor
AC125V	5A	0.7A	4A	1.3A
AC250V	5A	0.5A	4A	0.8A

Wire ratings

Wire ratings (Un)	
AWG	insulation level (V)
20	300

Position switch

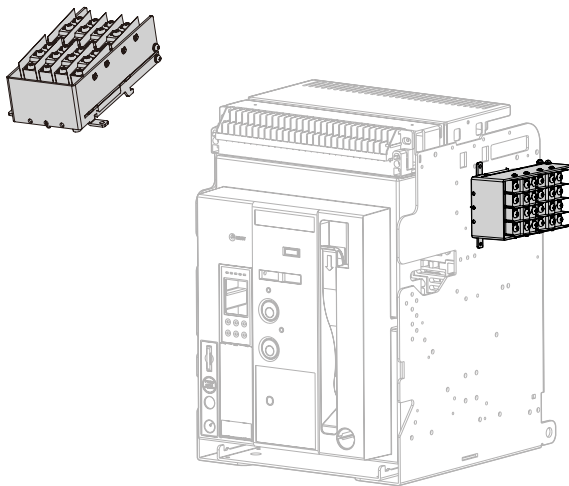

Connection diagram

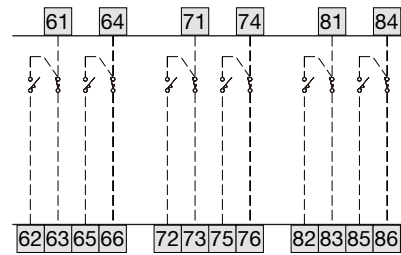

Test position	Connection position	Isolation position
61-62 a	71-72 a	81-82 a
61-63 b	71-73 b	81-83 b
64-65 a	74-75 a	Insert position
64-66 b	74-76 b	
67-68 a	77-78 a	
67-69 b	77-79 b	91-92 a
		91-93 b

- This switch is for indicating the position of ACB in the chassis. It is mounted on the side of chassis.
- Indicating position Connected/Test/Isol/Insert.
- Only one switch is applicable.

"a" contact = NO contact
 "b" contact = NC contact

Ratings

Load	Resistance	Lamp	Inductor	Motor
AC125V	10A	1.5A	6A	2A
DC30V	6A	3A	6A	3A
DC125V	0.6A	0.1A	0.6A	0.1A
DC250V	0.3A	0.05A	0.3A	0.05A

References

References	Inserted	Isolated	Test	Connected
HWX570	-	1C	1C	2C
HWX571	1C	1C	1C	1C
HWX572	1C	1C	3C	3C
HWX573	2C	2C	2C	2C

Position switch operating sequence

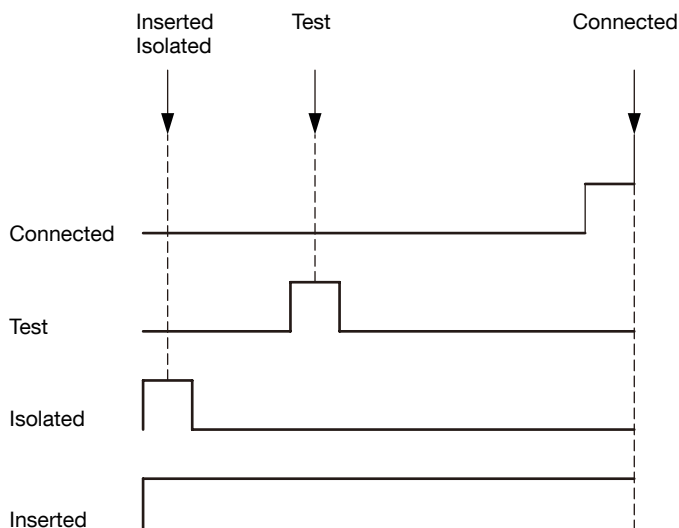

View

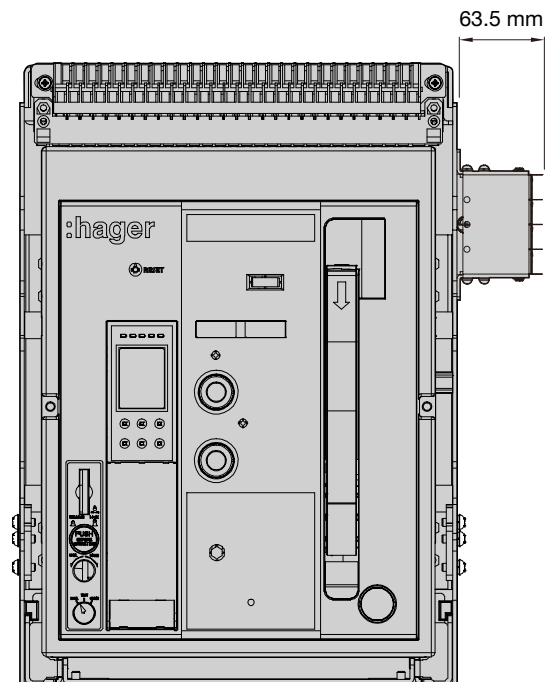

Lifting lugs

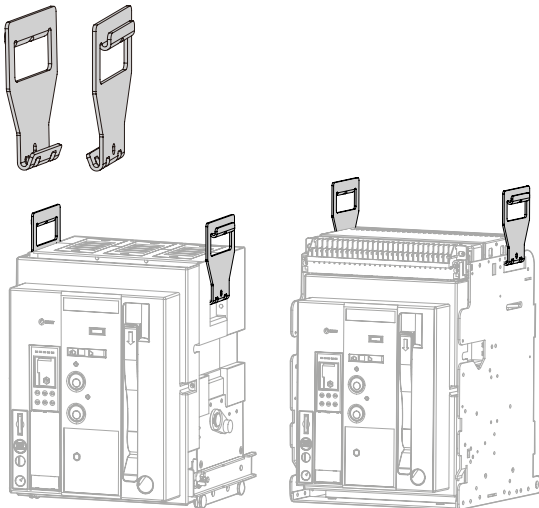

- A device to make an ACB easy to shift.
- Hang it to both handles of the arc shield, chassis, and ACB.
- When handling products, please be sure to use crane. In case of products under 3,200A and handling chassis only, please comply with safety regulation.
- Offered 2ea of 1set as a standard in 5,000A "C" frame.

Mechanical interlock kit

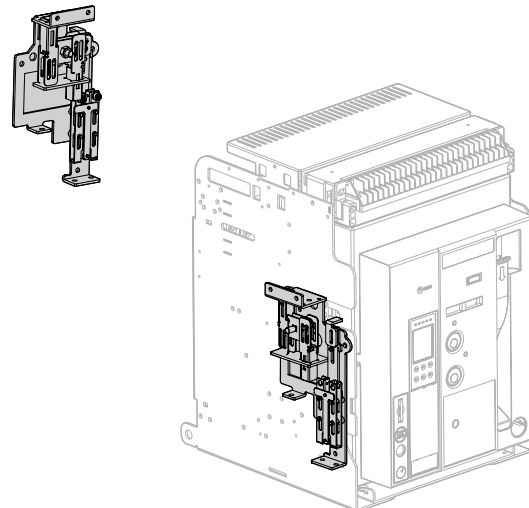

- It is used to interlock closing and trip between two or three breakers mechanically so as to prevent unintended operation at the same time.
- The MI is a safety gear installed in ACB for distribution line and it creates a mechanical interlock between two or three circuit-breakers through each ACB's open/close work.
- To operate the MI every component linked to the MI unit and the MI must be combined before use.
- MI unit is separate product. After installing ACB it is additionally attached.
- When ordering MI wire of parts all components linked to the MI unit are provided.

Phase insulation barrier

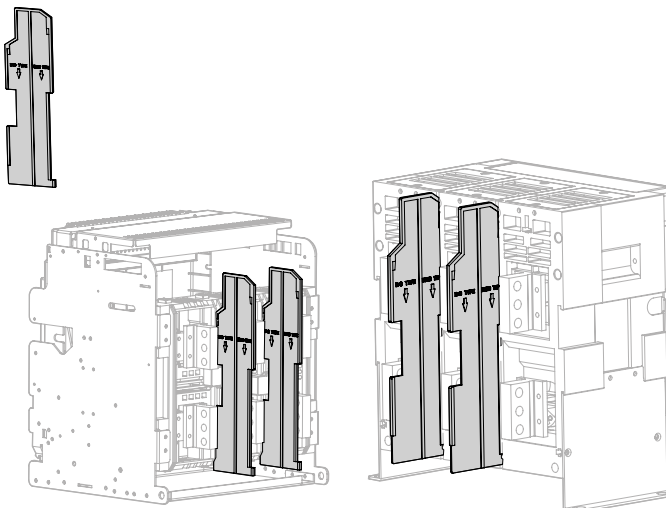

- Phase insulation barrier prevents the arc which may arise and result in short-circuit between phase in advance.

ON/OFF button lock

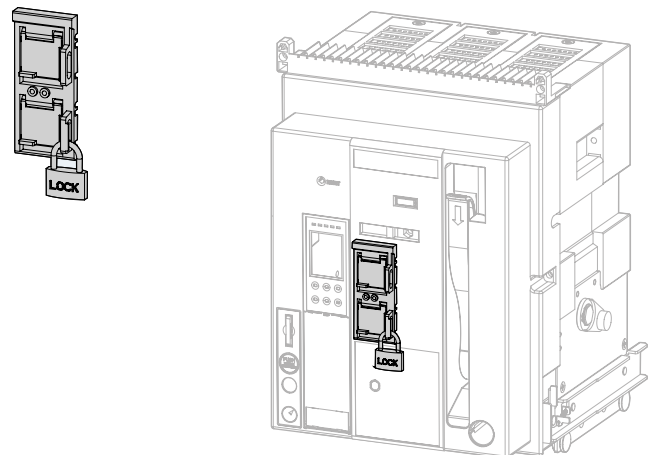

- Prevents manual operation of ACB's closing/tripping button due to user's wrong handling.
- It is not possible to handle on/off operation under the "Button lock" status.
- Padlock is not included, key locksize: Ø5-Ø8

OCR portable checker



- ACB HW portable checker tests for the operation of OCR (Long time/Short time delay/Instantaneous/Ground fault).
- It is possible to set current level, phases, and frequency for OCR's test.
- All testing factors are adjustable through front monitor and you can check operating time.
- Battery equipped inside (Available without external power source).

Keypad

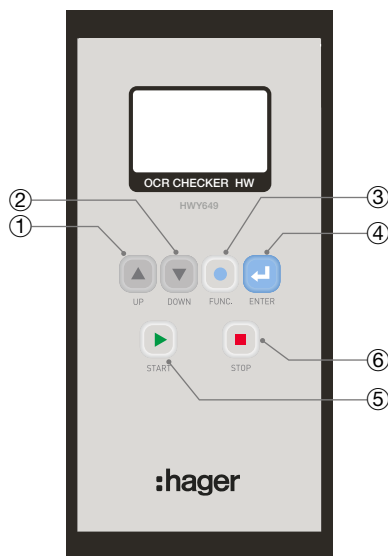

Nr	Button	Function
1	UP	move menu and increasing setpoint
2	DOWN	move menu and decrease setpoint
3	FUNC	move to the previous menu and return to the setup screen
4	ENTER	save the settings and move the number of digits of setting current
5	START	waveform occurrence
6	STOP	waveform stop

Connection diagram

Item	Specifications
external power	input: AC/DC100-200V,50/60Hz output: DC24V,2.5A
battery	Alkaline 9V: 3EA
trip time measurement	0-999,999 sec
test output	0.3In-17In
output precision	±20% (1In-17In)
size (HxWxD)	193mm x 111mm x 45mm

Externals

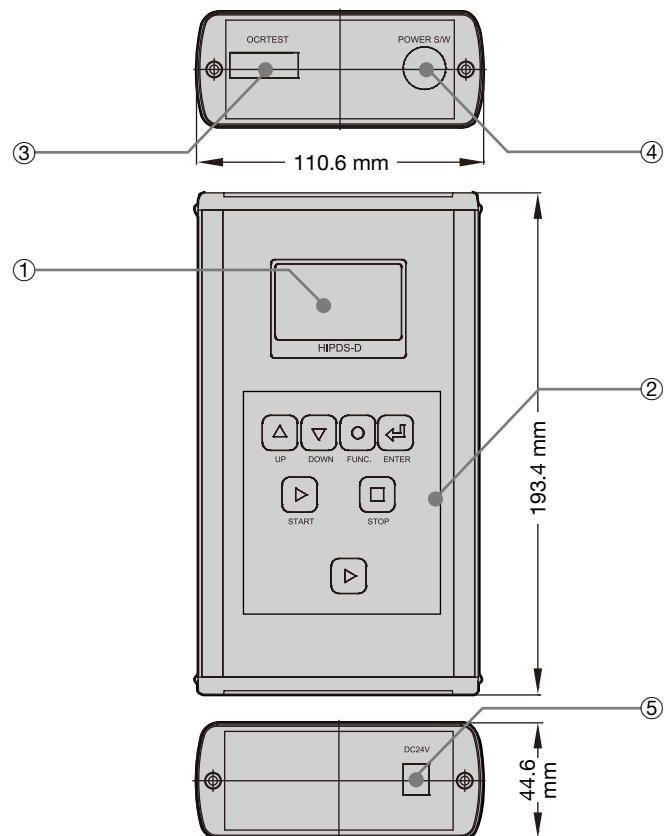

Nr	Button	Function
1	LCD	menu, setting current, trip time
2	keypad	move menu and setting
3	signal output terminal	OCR connection terminal
4	power switch	On/Off
5	terminal	control terminal of checker

Key lock device

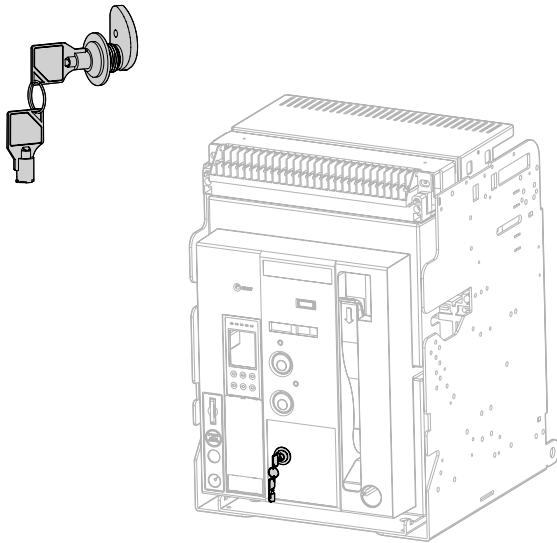

Key Ronis lock and key Castell lock

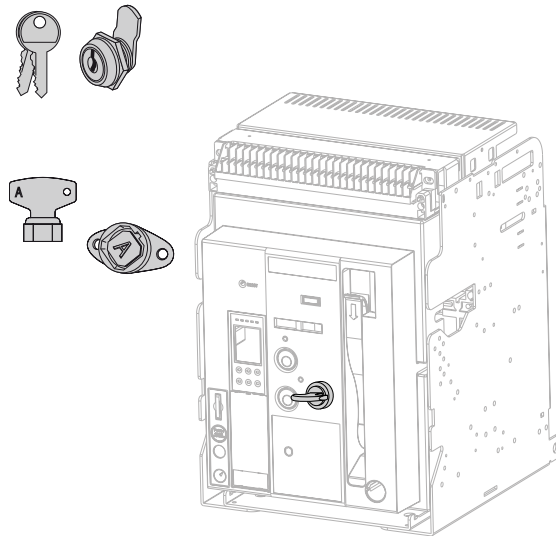

- The key lock prevents the circuit breaker closing, it maintains interlock condition (Mechanical prevention).
- When the key has been unlocked you can operate spring changing/manual on or off, when the key is removed from circuit breaker it becomes interlock. The key doesn't turn to lock position until user push the off button, when the key is locked.

Kirk and Profalux type of locks may also be applied.

Key interlock

Configure the system with three breaker mounted key lock device. Only two breakers are possible to input with 2ea key, and the other breaker can supply stable load with interlocking.

- ACB 3 is interlocked

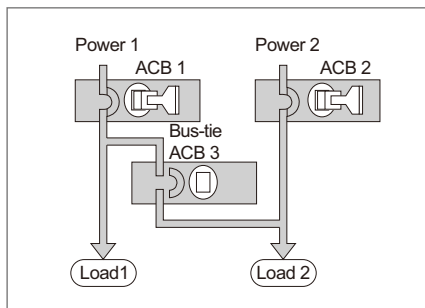

ACB 3 cannot be closed.

- ACB 2 is interlocked

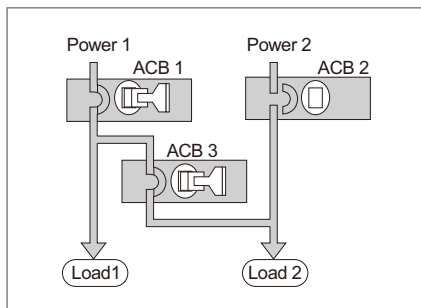

ACB 2 cannot be closed.

- ACB 1 is interlocked

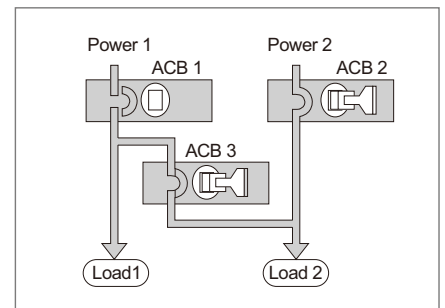

ACB 1 cannot be closed.

Wrong insertion preventer

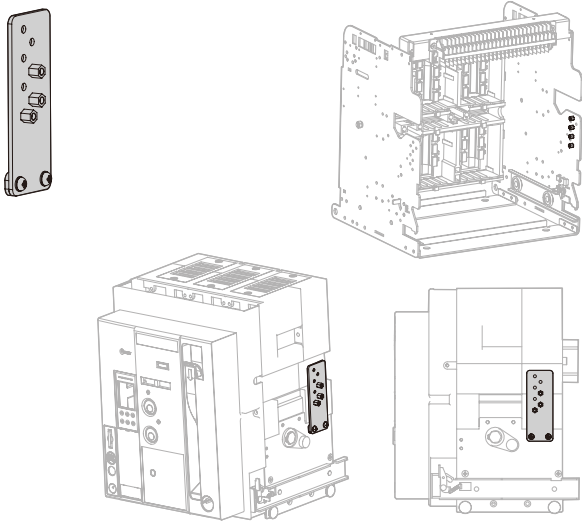

- When the main body of ACB is inserted to the chassis if the ratings of ACB do not match with chassis it mechanically prevents ACB from being inserted into chassis of ACB.
- Each part will have been installed on body or chassis.
- This device is set by CT rated current.

Mounting position according to rated current

CT	Mounting position	
	chassis	ACB
0 = without OCR	ADEG	236
T = 630A	ABDF	357
H = 800A	ABDE	367
J = 1,000A	ABCG	456
K = 1,250A	ABCF	457
L = 1,600A	ABCE	467
M = 2,000A	ABCD	567
N = 2,500A	BCDE	167
P = 3,200A	BCDF	157
Q = 4,000A	BCDG	156
S = 5,000A	BCEF	147

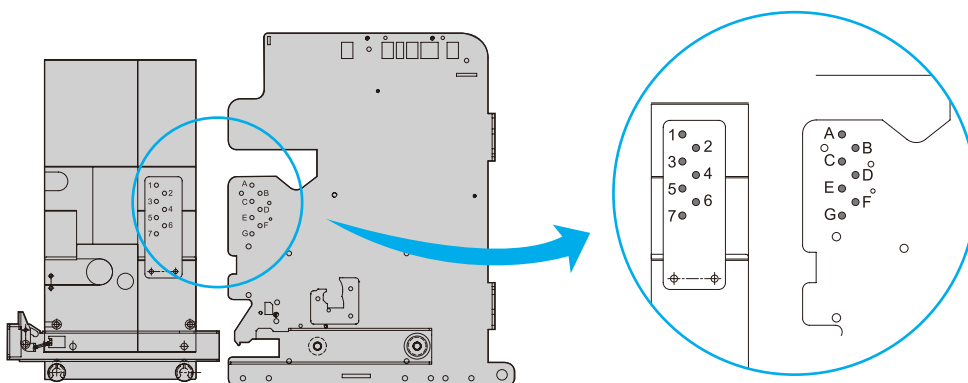

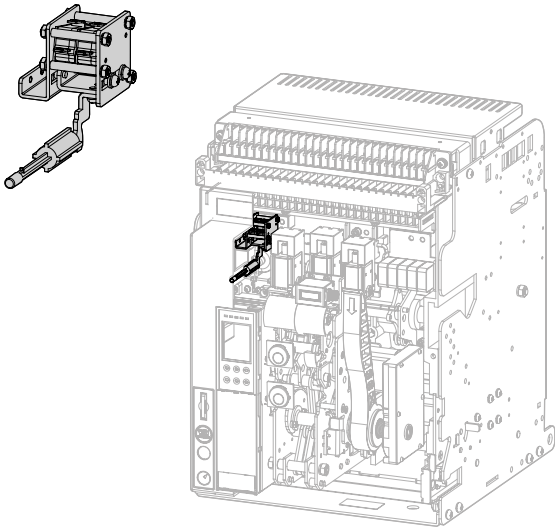
OCR and alarm switch reset

- When a circuit breaker tripped by fault current or over load and only if the circuit breaker has been tripped by OCR, the Manual Reset Button operates interlock and resets the interlock to restore electric lines after fault factors have been removed.
- When the ACB is tripped by OCR it provides functions of interlocking above mechanism and output contacts (2NO) which check operation of ACB by OCR as well. The output contact displays OCR operation by long time, short time delay, instantaneous and ground fault. And resetting above mechanism occurs.
- Except above functions when emergent restoration of electric load is needed it automatically reset itself to get ready to open immediately after trip and reset only output contacts.

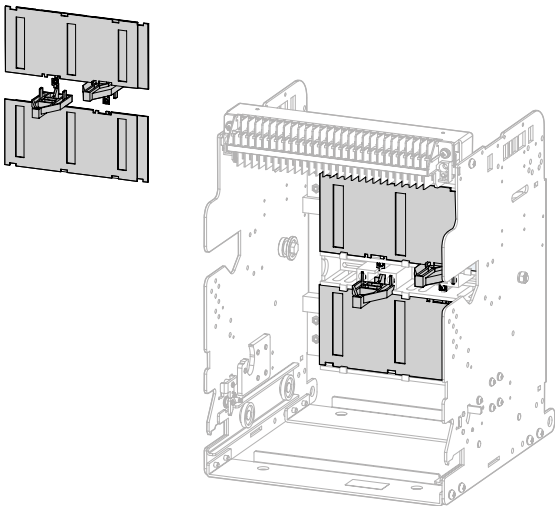
Safety shutter lock

- An automatic safety device to protect the connectors of main circuit by cutting off dangerous contact from outside while the breaker is drawn out.
- Shutter lock is a locking device which prevents safety shutter from being opened when it is closed. (Key lock is not included. Size is Ø5-Ø8)

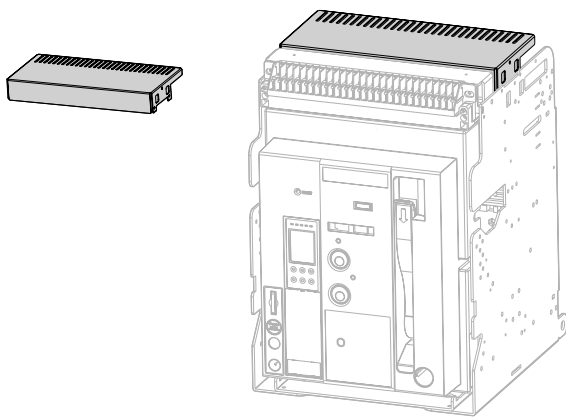
Arc shield

- Arc which may arise while breaking fault current is extinguished first by arc chute in main body of circuit breaker and then completely extinguished by arc cover.

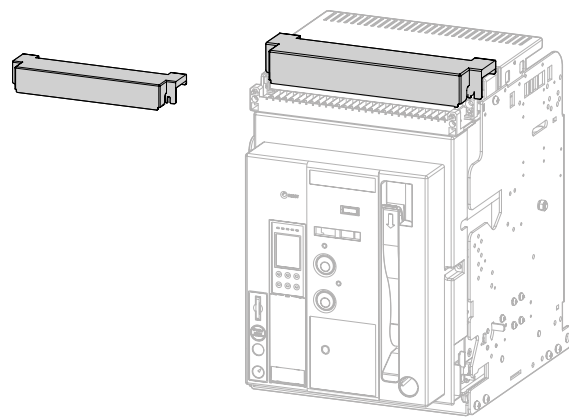
Control terminal protection cover

- Protects control terminals which are exposed to the outside, and prevent damage from foreign substances.

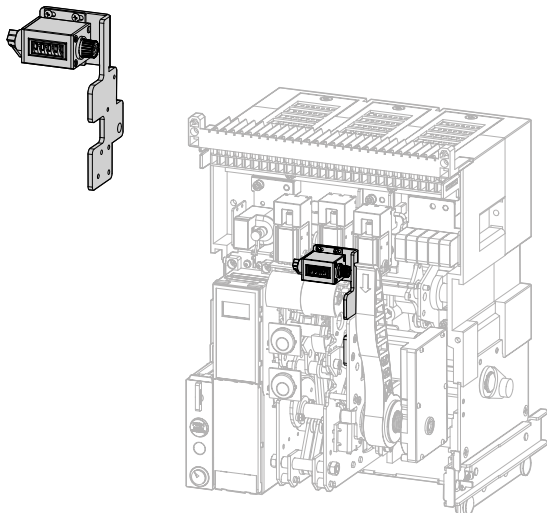
Counter

- Displays the total number of on/off operation of ACB
- The counter displays the total number of on/off operation of ACB.

Remote control temperature unit

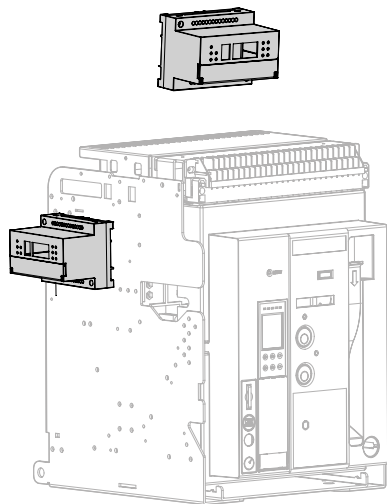

- RCTU is installed on the chassis or inside of panel, and communicates with Modbus/RS-485 basically.
- It can be purchased separately and can be operated with temperature alarm unit at the same time: RCTU
- It is used with temperature sensor.
- Temperature alarm unit is a device to show the busbar's temperature through a sensor inside of ACB.
- Temperature sensor can be installed up to 3 and alarm can occur when it reaches the specified temperature.
- Display the maximum temperature on the segment LED and transmits through a network.
- Installed on the chassis or inside of panel, and can be operated with remote closing & trip unit at the same time.

Contact specification

Division		Range of application
ACB control	contact ratings	10A, 240V AC, 30V DC
	max. switching power	2,400VA, 300W

Temperature sensor

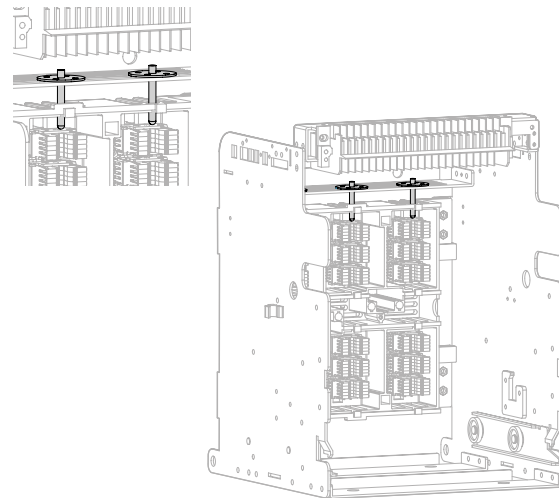

- The RCTU is used with temperature sensor installed inside of the ACB.
- The temperature sensor is installed in designated position. However user can change the position to applicable extra site.

Temperature sensor support

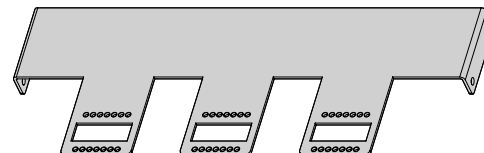

Different supports are designed to make easier the installation of IR temperature sensor:

- Frame A, 3P and 4P
- Frame B, 3P and 4P
- Frame C, 3P and 4P

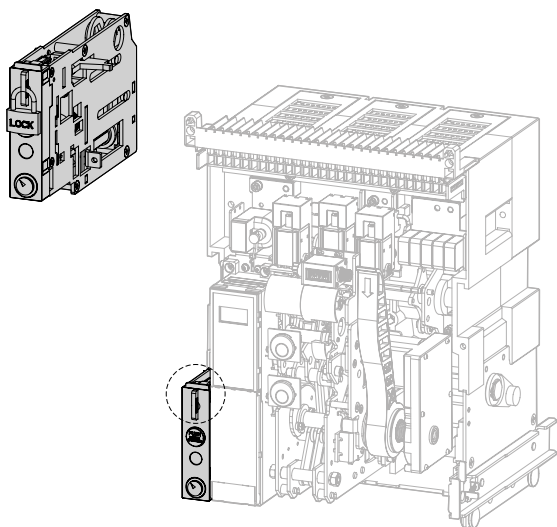
Draw-in/out device mechanism

- Draw-in/out device unit is mounted on the body of draw type ACB as standard.
- Draw-in/out device unit consists of draw-in/out handle storage space, push button, position indicator, pad lock.
- Position pad lock is a safety device as locking draw-in/out function in connected/test/sol position.
- This device is offered as standard except key lock. Available key lock size: Ø5-Ø8

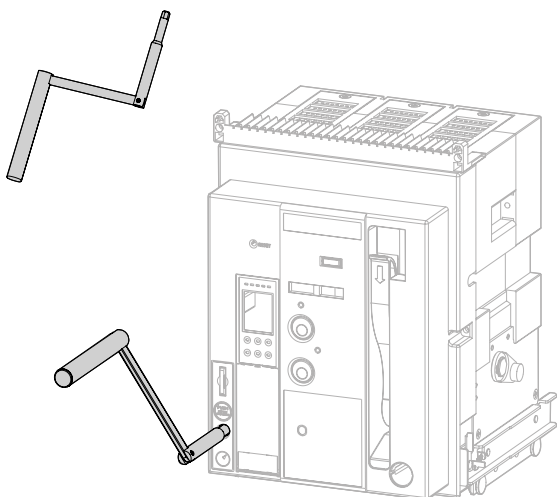
Draw-in/out handle

- Draw-in/out handle is included in storage place for draw-out type.



Neutral CT



- The NCT is additionally applied for 3-pole circuit breaker when it is connected to distribution line (3 phases 4 lines).
- For distribution line (3 phases 4 lines) 3pole circuit breaker can protect the ground fault however, we can not classify unbalanced load and ground fault. To complement this when only a ground fault occurs the NCT senses the N phase load and operates the GFT.
- When connecting a relay or electric instrument checking phase is mandatory. Please connect the designated terminal.

Dimensions (mm)

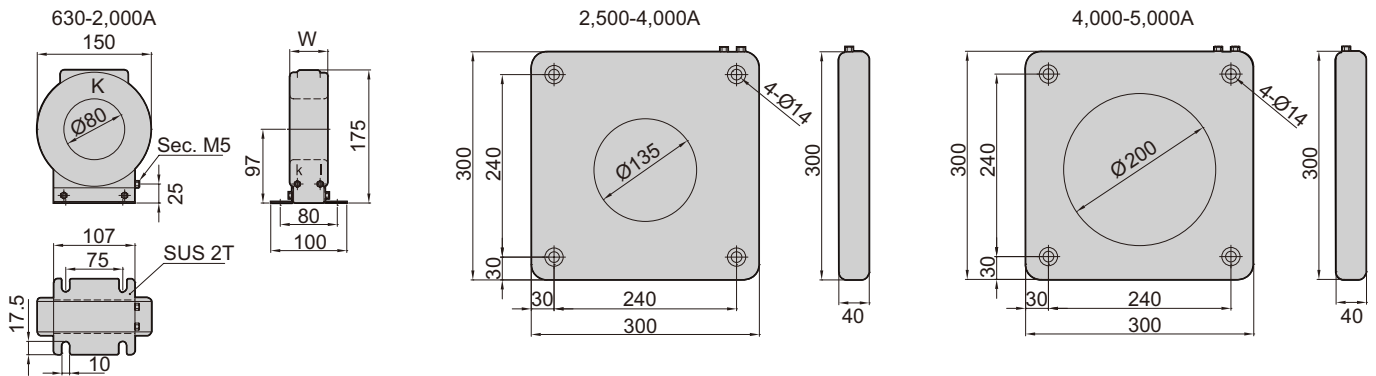

Door flange

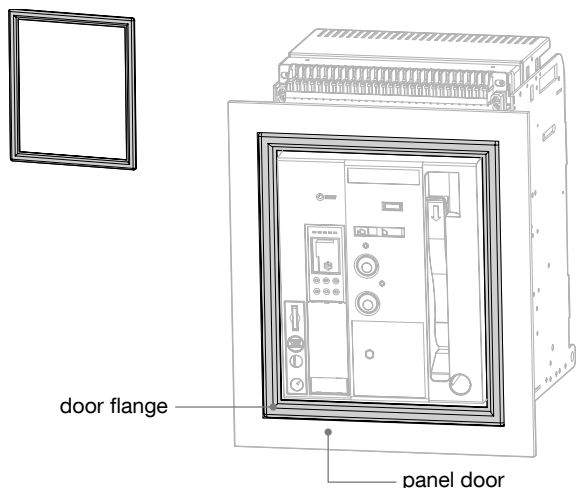

- Protects the protruding front of ACB and the cutting side of panel door by attaching it to the panel door.
- Both fixed/draw-out type are the same size of the panel cutting, even if the dust cover is installed.
- Refer to dimension for panel cutting size.
- Protection rating of IP30.

Panel door cutting dimensions (mm)

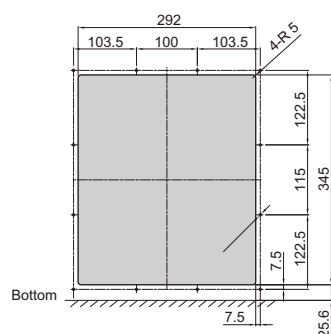

Dust cover

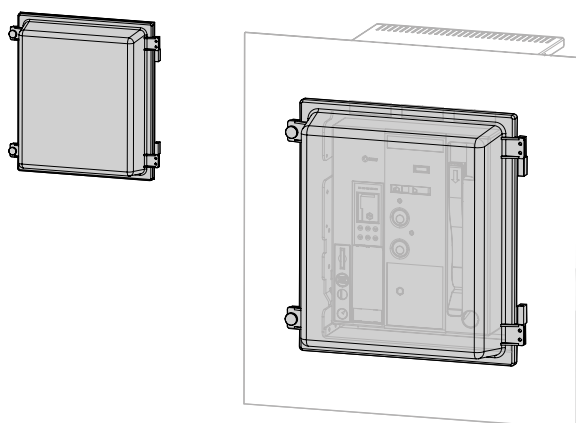

- A protective cover which completely protects the front panel of ACB from dust and moisture, with a protection rating of IP54.
- Locks the cover in the test or connected position.
- Refer to dimension for panel cutting size.

Circuit diagrams

OCR Circuit diagram (Energy type)

Main circuit

Over-current protective device

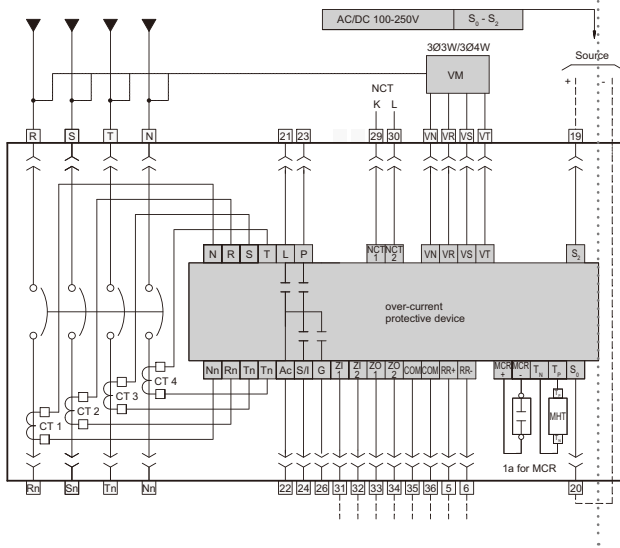

Common Circuit diagram

Alarm contact Charging circuit Ready to close Closing circuit Opening circuit Secondary shunt trip coil

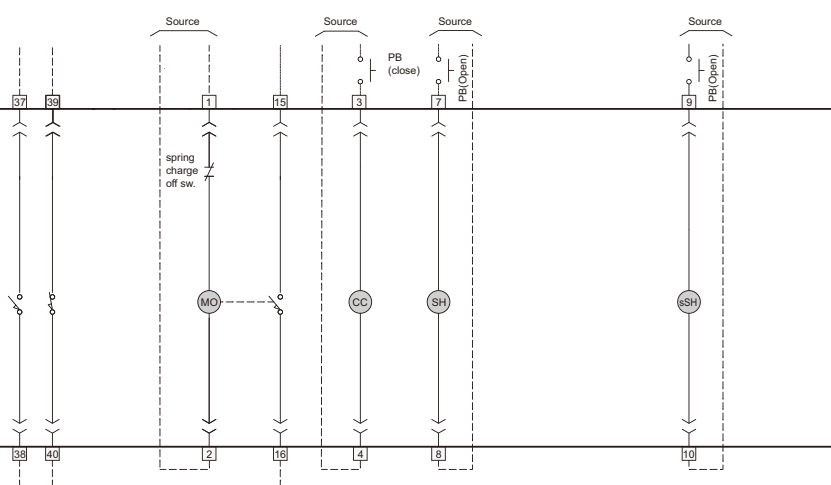

Symbol description

CT	current transformer
L	LTD terminal
P	PTA terminal
G	GFT terminal
S/I	STD/INST terminal
Ac	common terminal
NCT	neutral current transformer
ZI	zone selective input
ZO	zone selective output
COM	communication (pc)
MCR+/-	MCR input terminal
Tp/Tn	MHT input source
MO	charging motor
CC	close coil (close)
SH	shunt trip coil (open)
sSH	secondary trip coil
UVT	undervoltage trip coil
MHT	magnetic hold trigger
S0/S2	protection unit source power
RR	remote reset

Terminal description

1 2	charging motor (MO) source power
3 4	closing coil (CC) source power
5 6	remote reset
7 8	opening coil (SH) source power
9 10	UVT coil / secondary shunt trip coil
15 16	ready to close contact (RTC)
19 20	OCR source power
22 21	LTD contact
22 23	PTA contact
22 24	STD/INST contact
22 26	GFT
29 30	NCT input terminal
31-34	ZSI input/output
35 36	communication (RS485)
37-39	OCR alarm contact
VN-VT	voltage module
43-60	AUX switch contact
61-96	position switch

- Manufacturer's wiring
- User's wiring
- ⌞ Disconnecting device (Draw-out type)

Under-voltage trip

Auxiliary sw.

Position sw.

MOC
Mechanical Operated
Cell switch

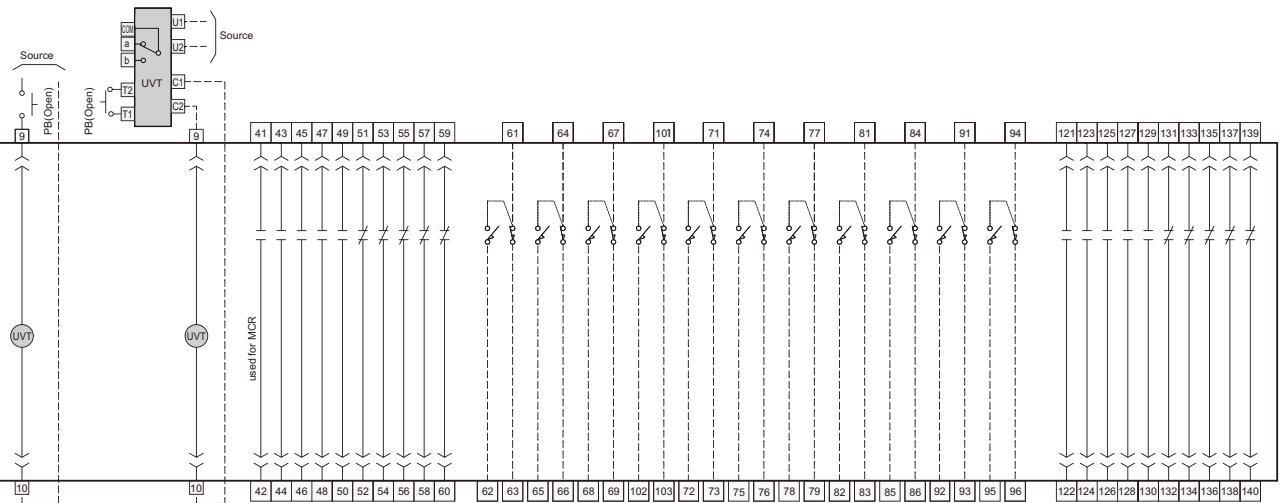

Test position
61-62 a
61-63 b
64-65 a
64-66 b
67-68 a
67-69 b
101-102 a
101-103 b

Connection position
71-72 a
71-73 b
74-75 a
74-76 b
77-78 a
77-79 b

Isolation position
81-82 a
81-83 b
84-85 a
84-86 b

Insert position
84-85 a
84-86 b
91-92 a
91-93 b
94-95 a
94-96 b

Additional auxiliary SW
5NO/5NC

"a" contact = NO contact
"b" contact = NC contact

Draw-out type lay-out

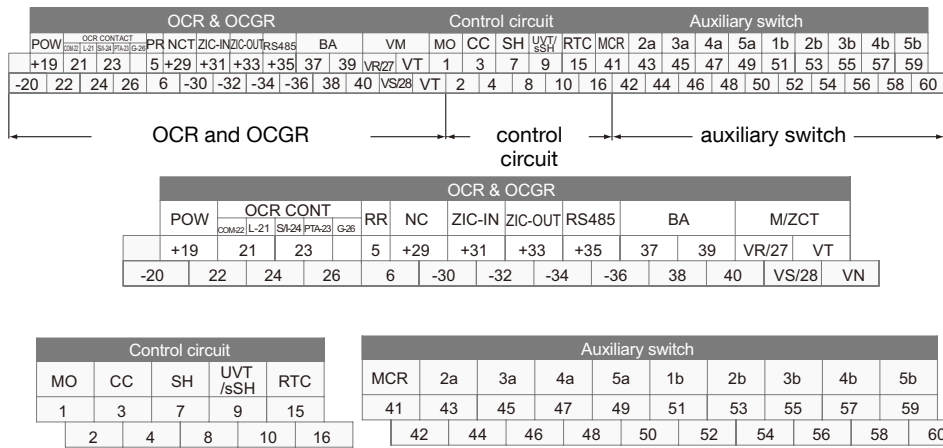

Over-current protective device (standard type)

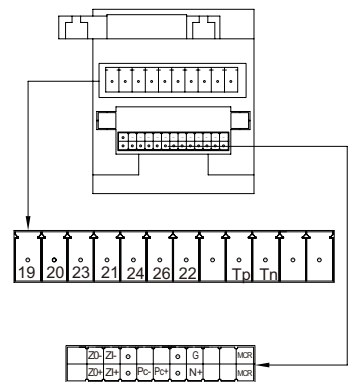

Fixed type lay-out

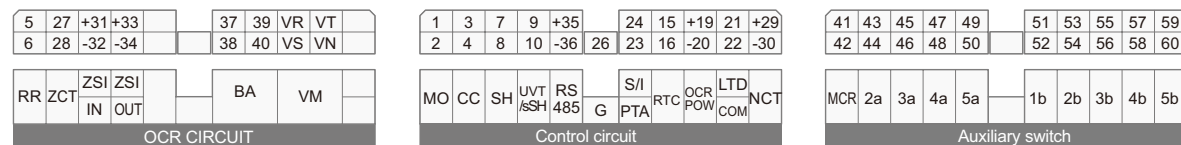

Front view (mm)

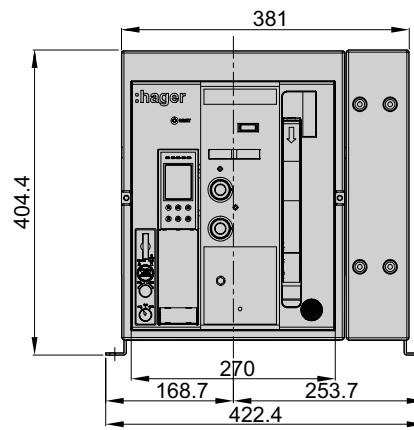
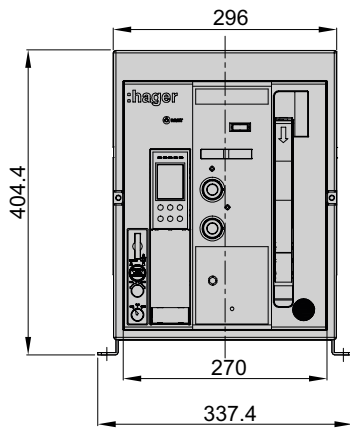

Vertical terminal connection (mm)

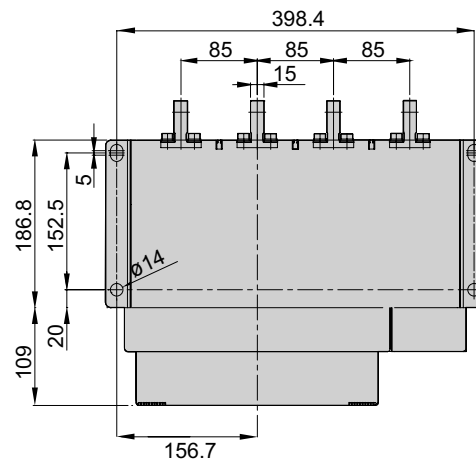
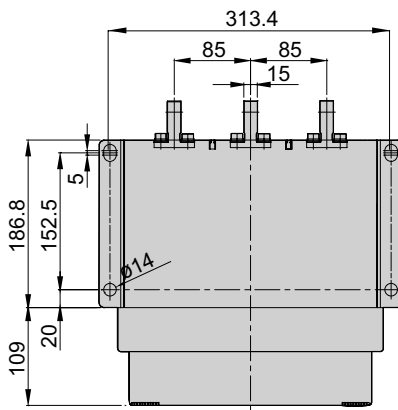

[630-1,600A]

[2000A]

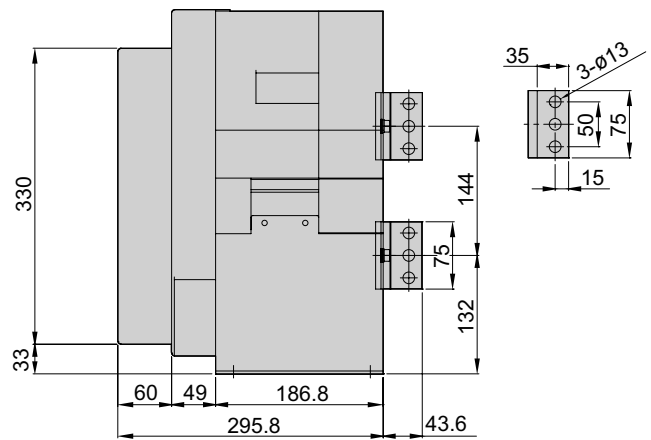
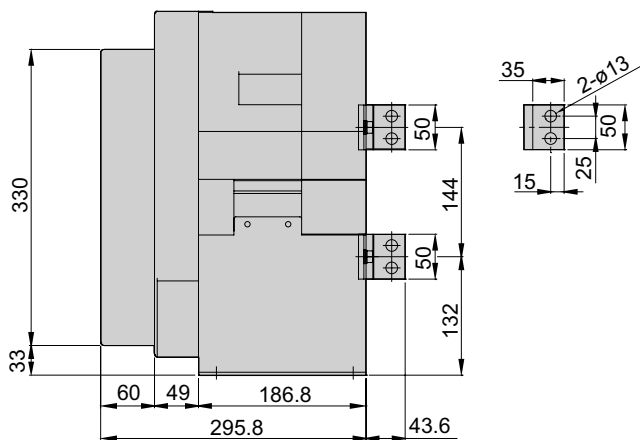

A frame 2,000A of ACB HW fixed type is applicable horizontal terminal only.

Horizontal terminal connection (mm)

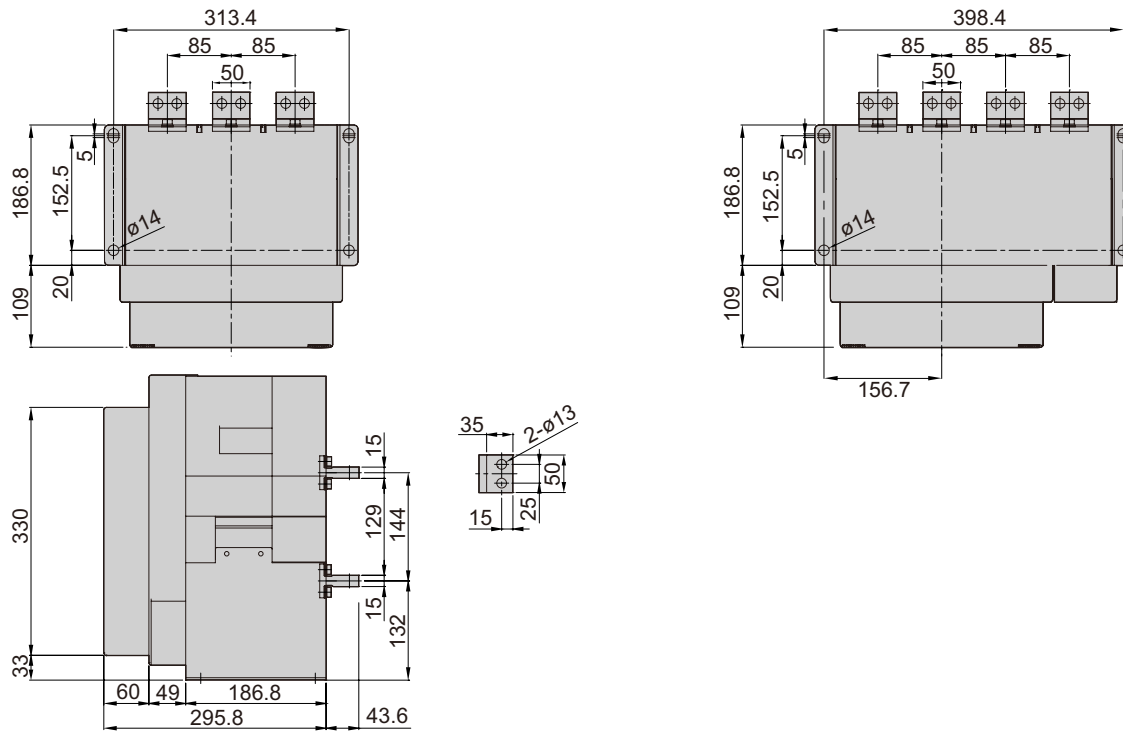

Front terminal connection (mm)
[630 - 1600A]

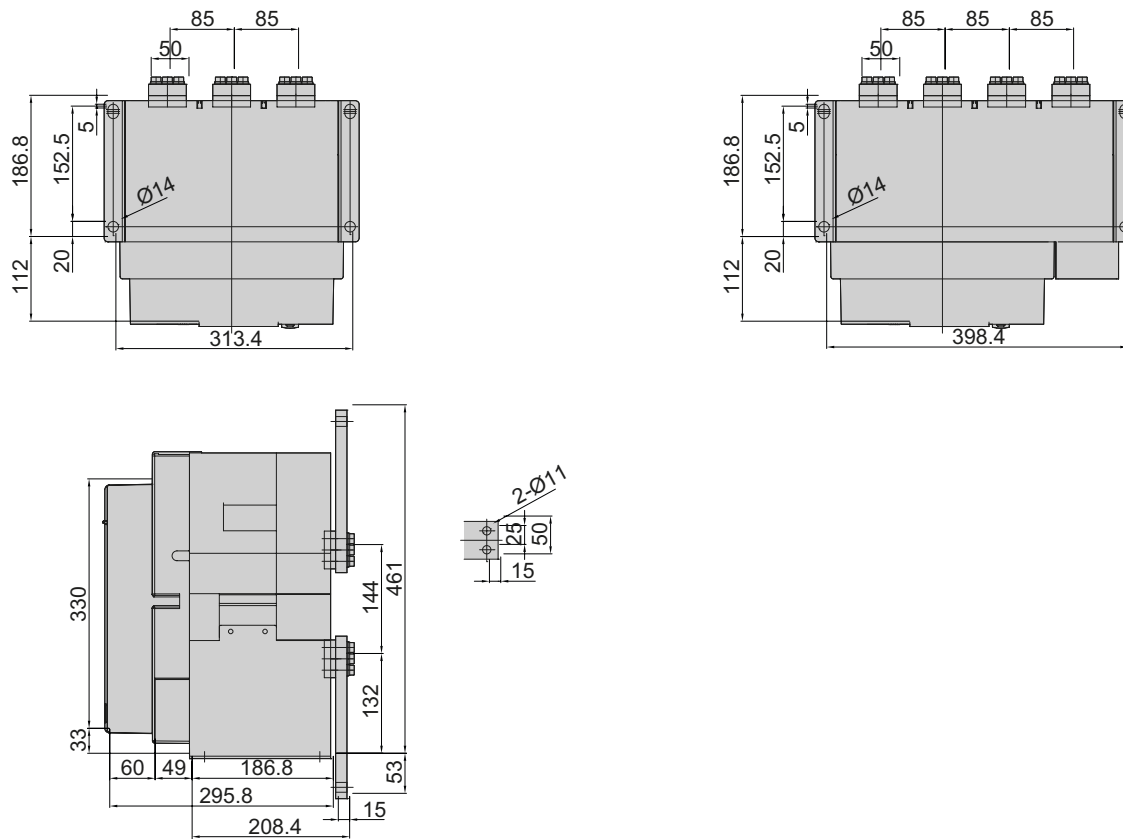

Front view (mm)

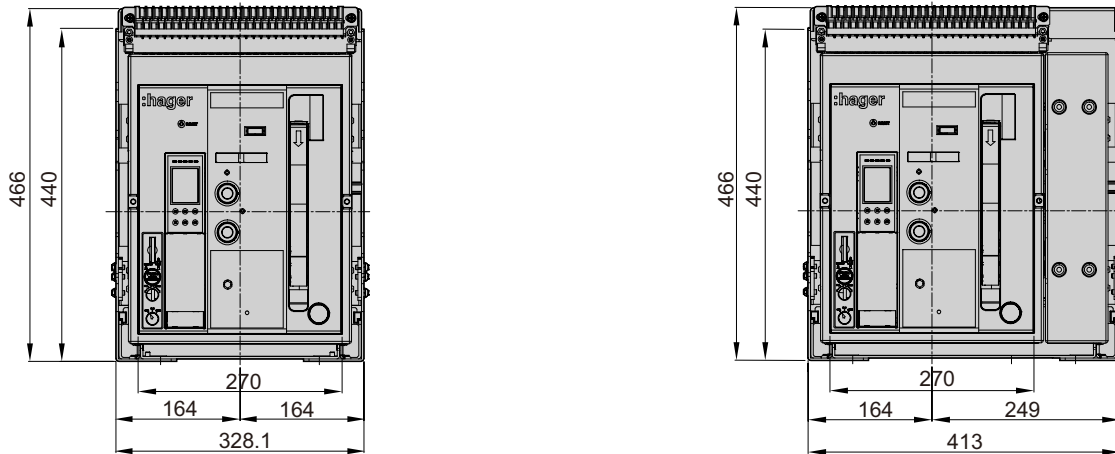

Vertical terminal connection (mm)

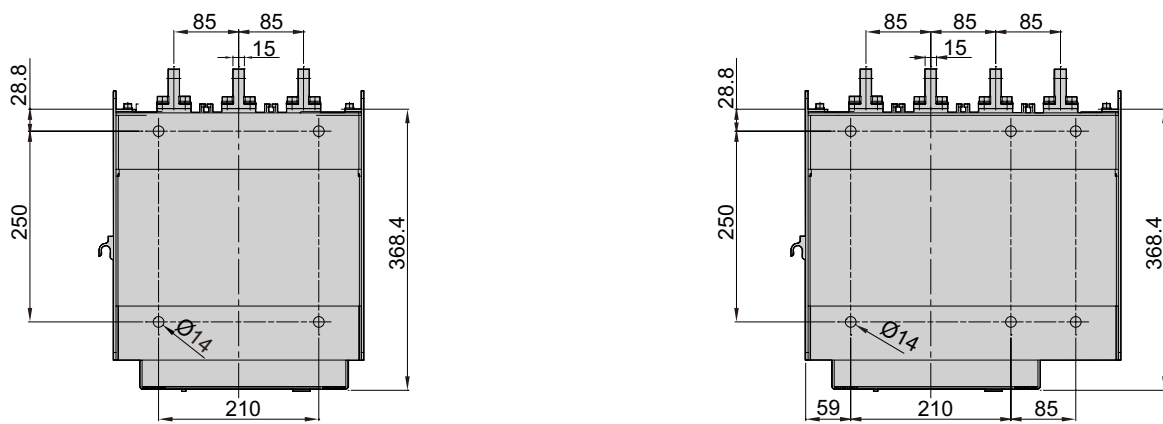

[630-1,600A]

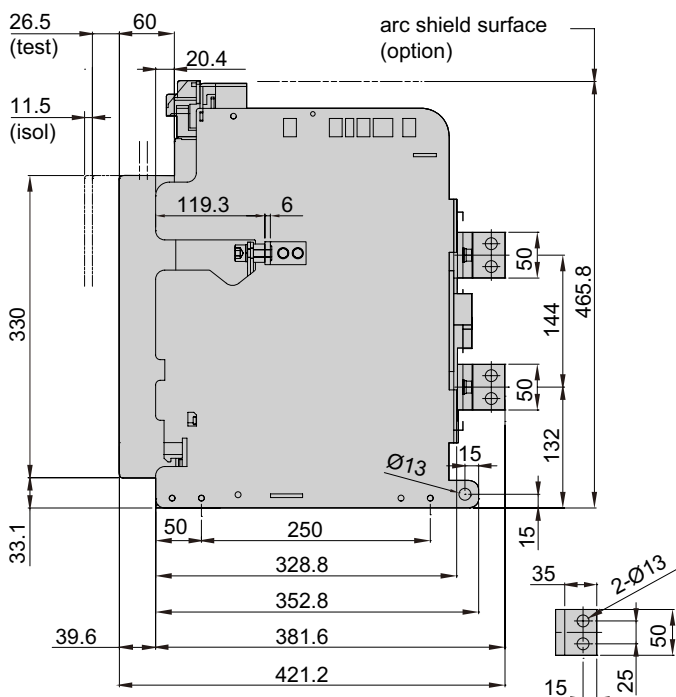

[2,000A]

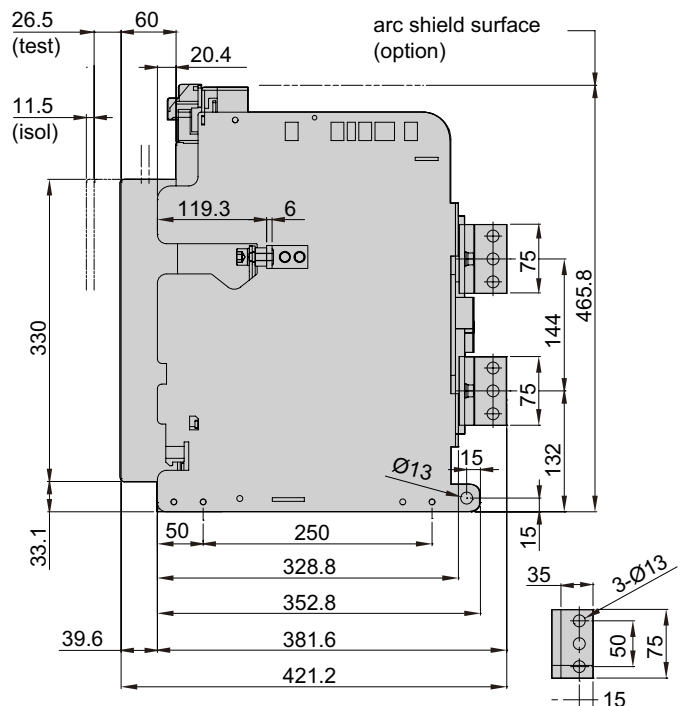

A frame 2,000A of ACB HW fixed type is applicable horizontal terminal only.

Horizontal terminal connection (mm)

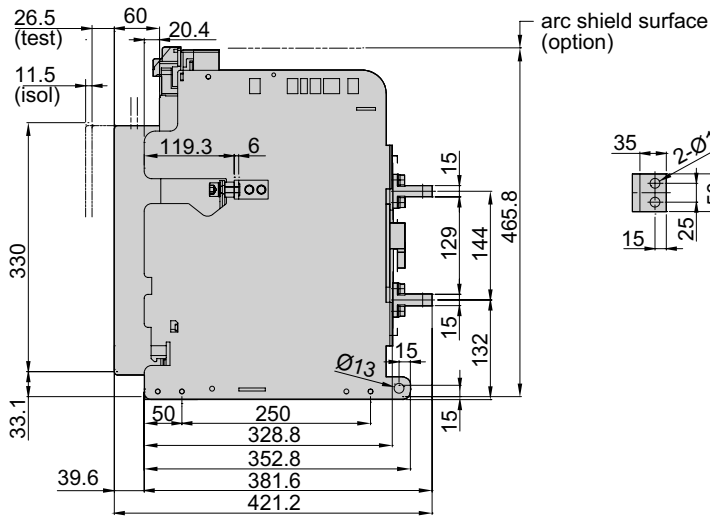
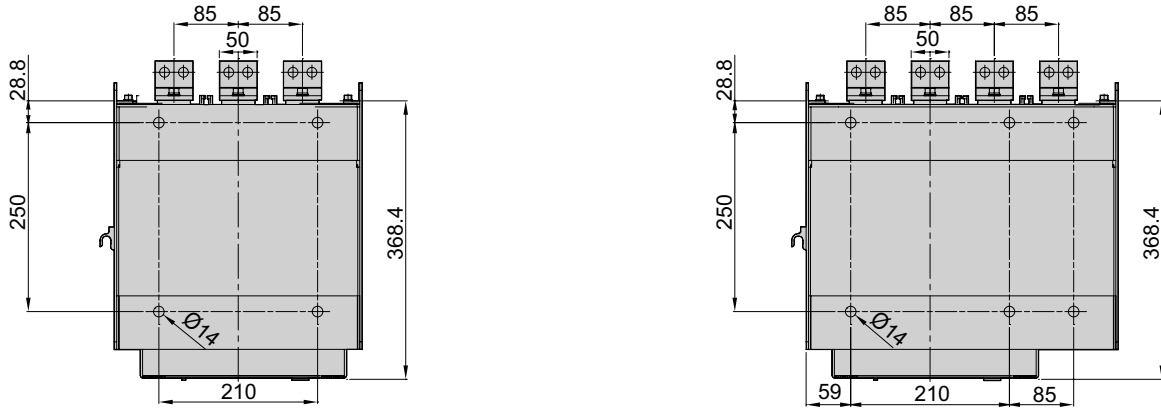

Front terminal connection (mm) [630-1600A]

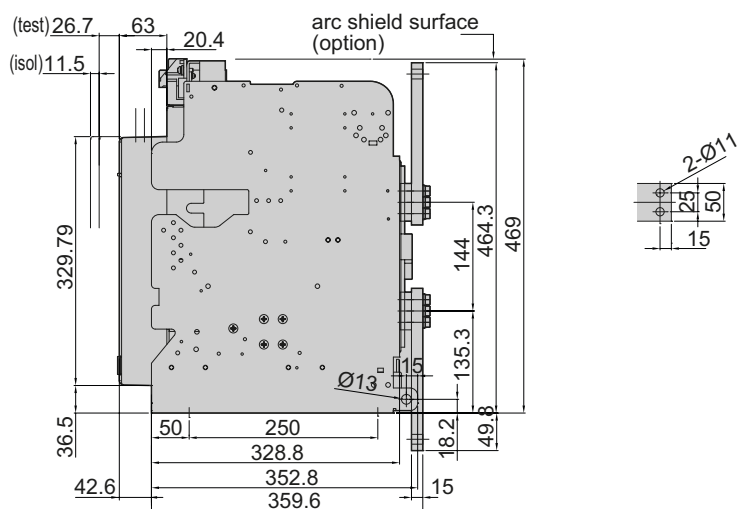
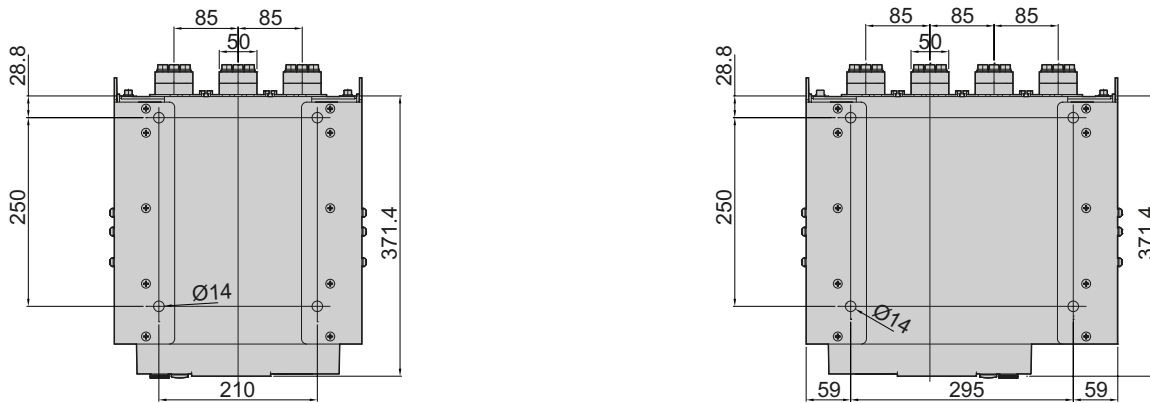

Front view (mm)

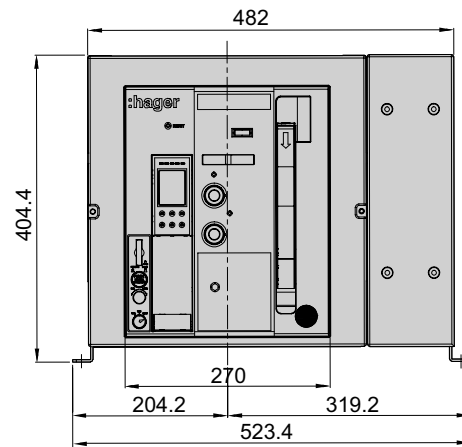
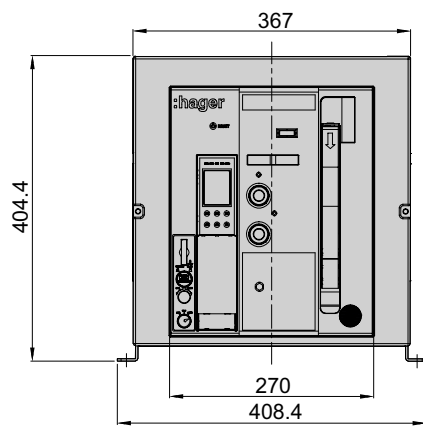

Vertical terminal connection (mm)

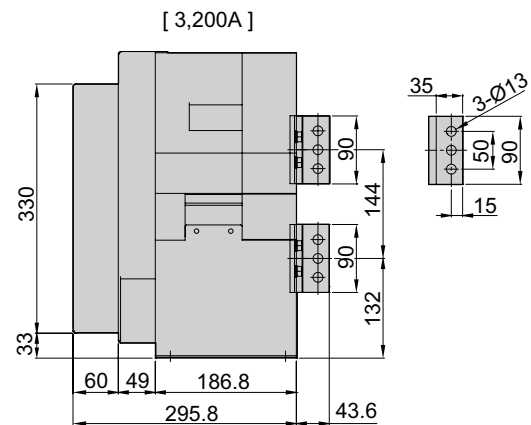
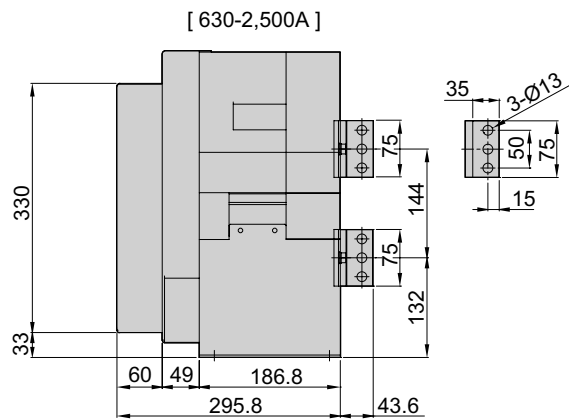
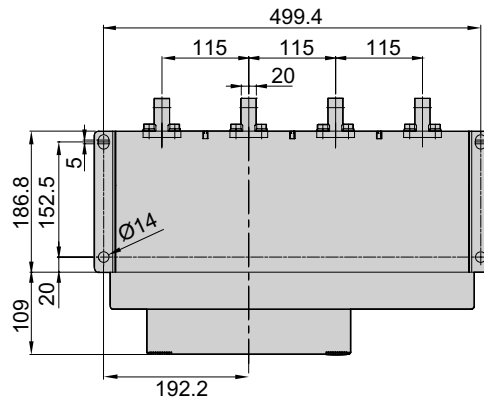
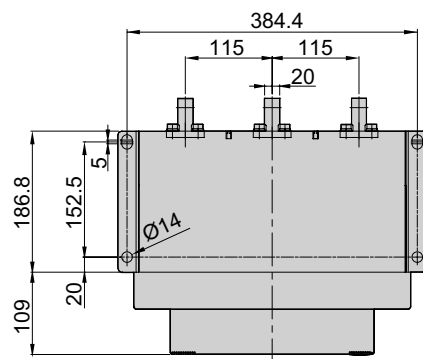

Horizontal terminal connection (mm)

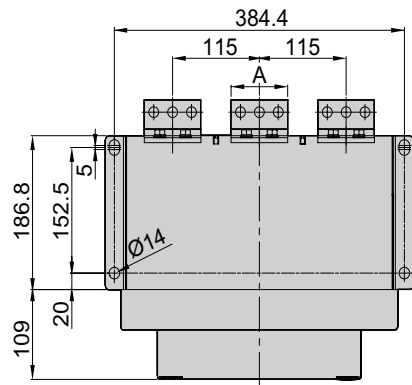

Range	A (mm)
630 - 2500A	75
3200A	90

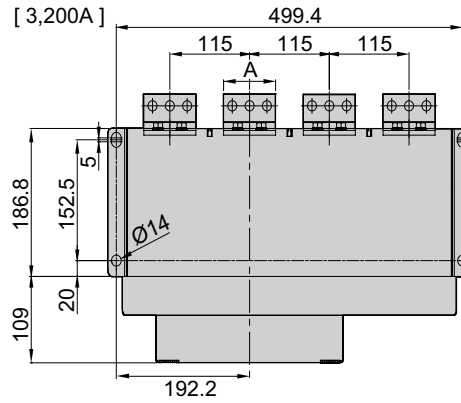

[3,200A]

[630~2,500A]

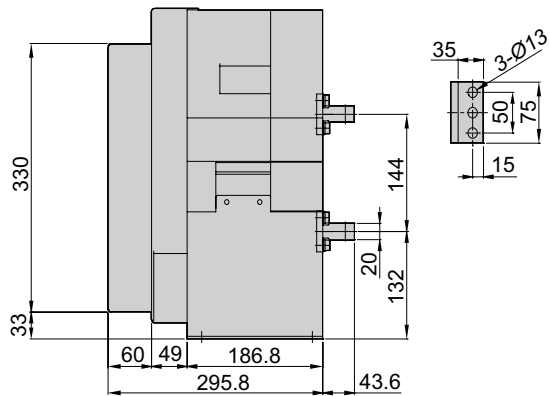
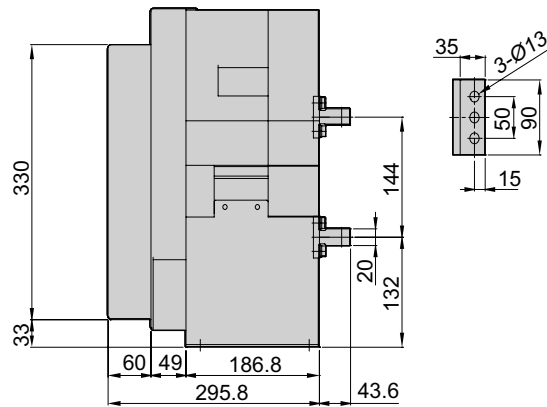

Front terminal connection (mm)

[630-3200A]

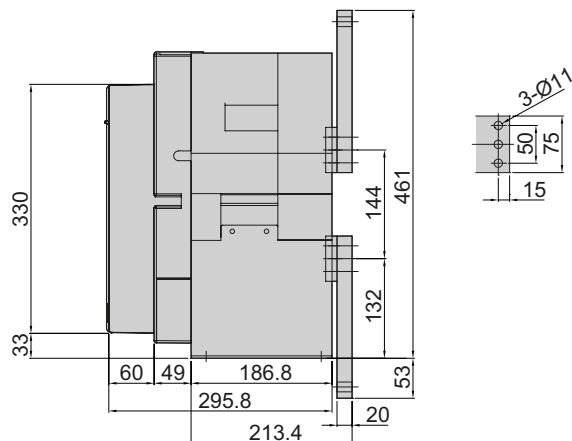
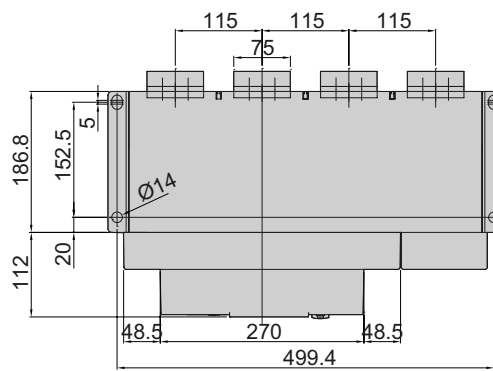
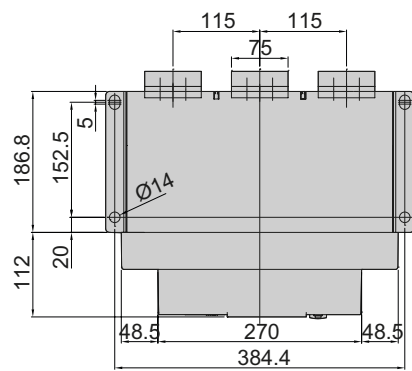

Front view (mm)

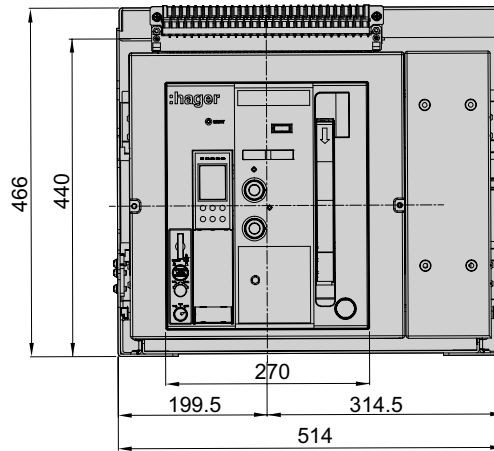
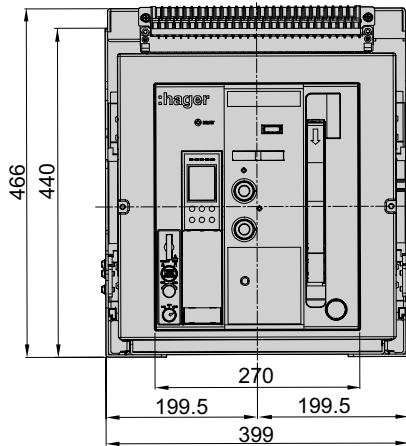

Vertical terminal connection (mm)

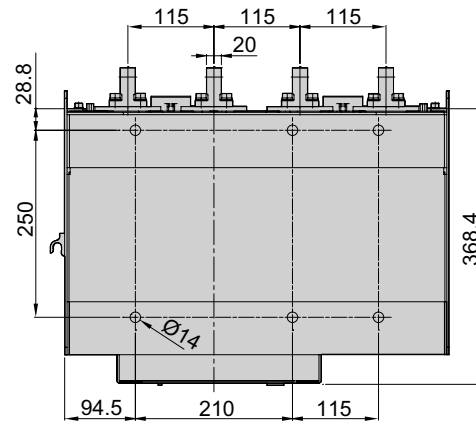
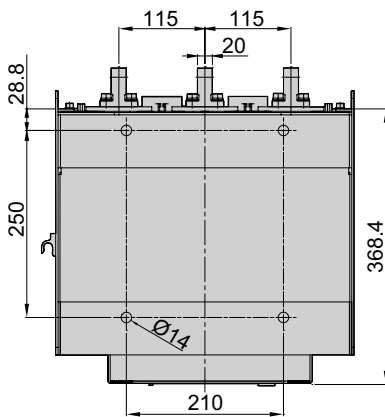

[630-2,500A]

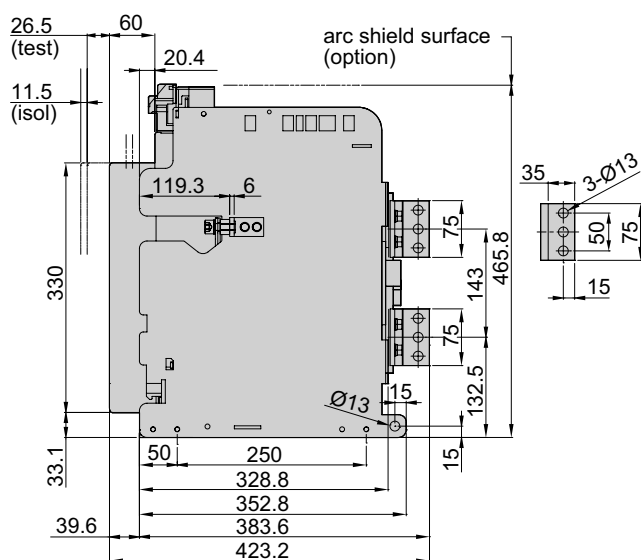

[3,200A]

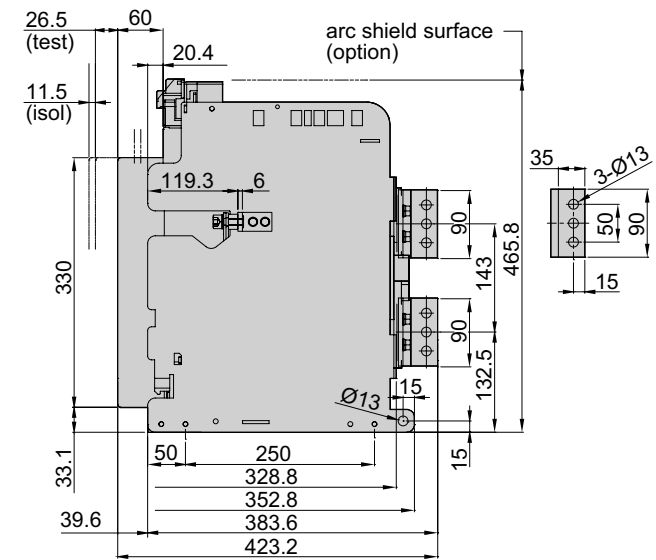

Horizontal terminal connection (mm)

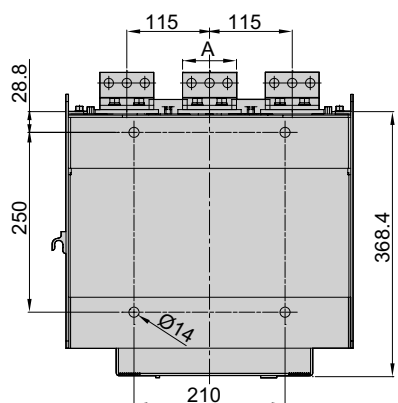

Range	A (mm)
630 - 2500A	75
3200A	90

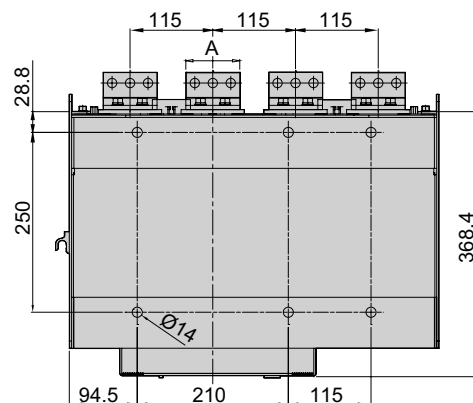

[630-2,500A]

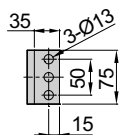
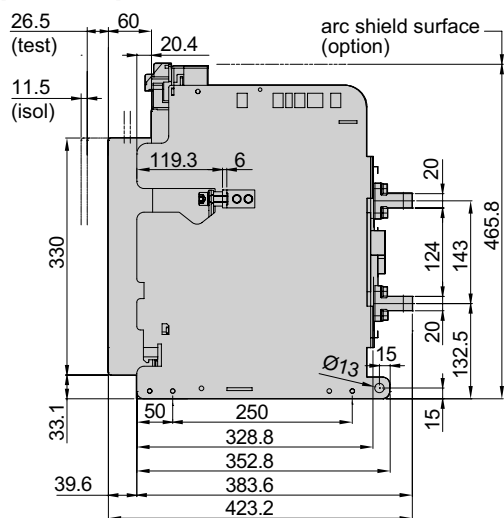

[3,200A]

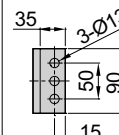
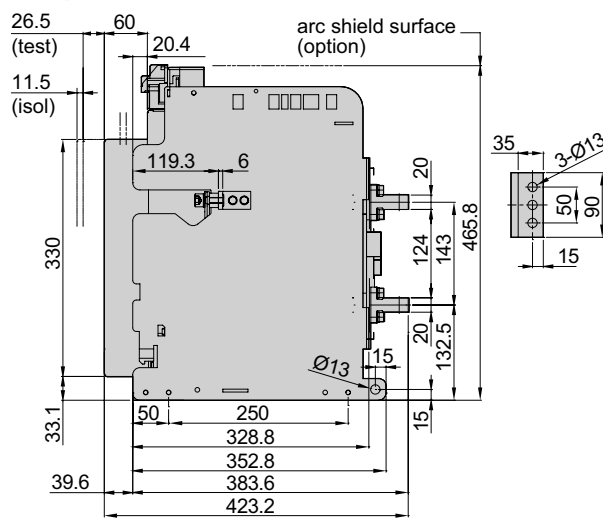

Front terminal connection (mm)

[630-3200A]

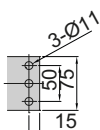
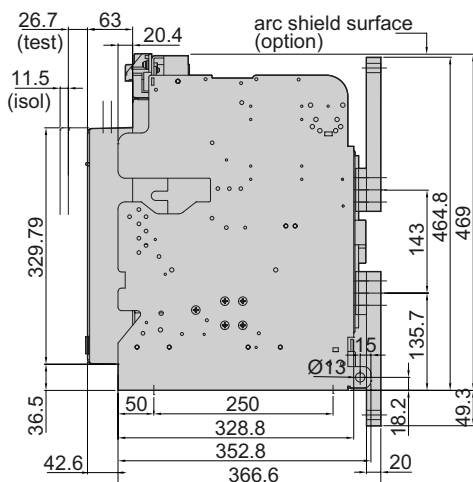
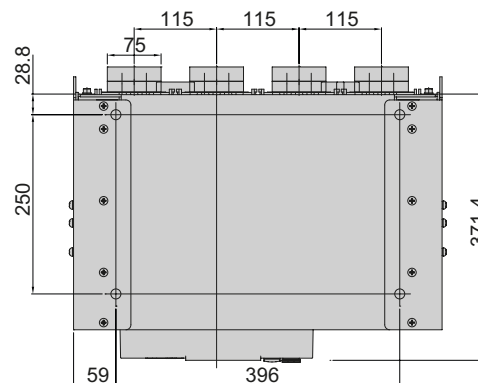
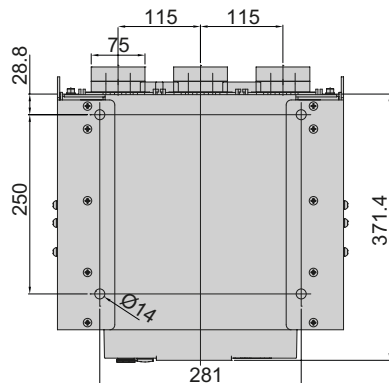

Front view (mm)

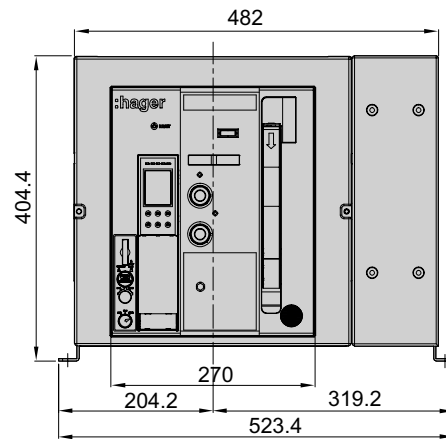
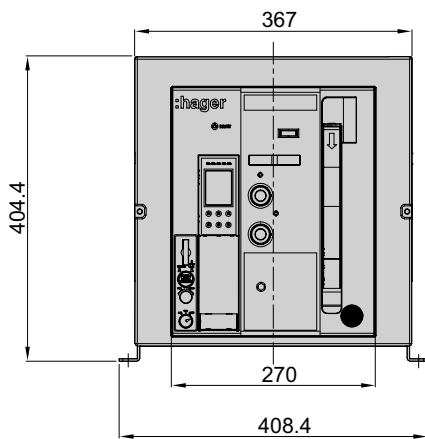

Vertical terminal connection (mm)

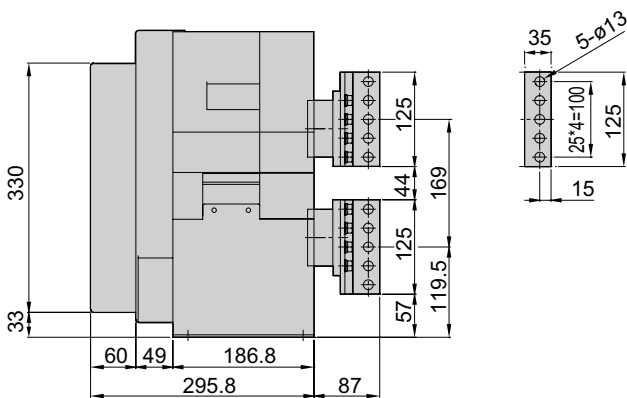
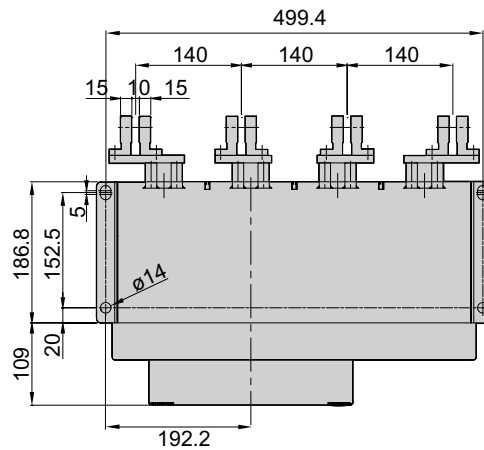
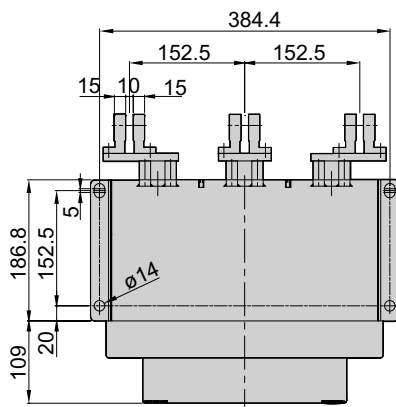

Horizontal terminal connection (mm)

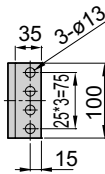
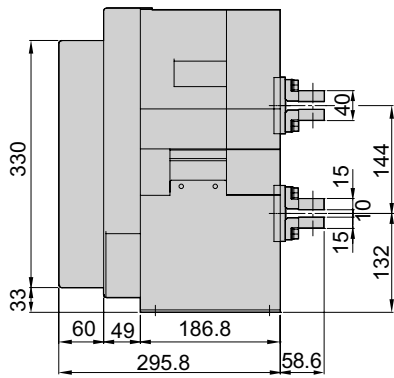
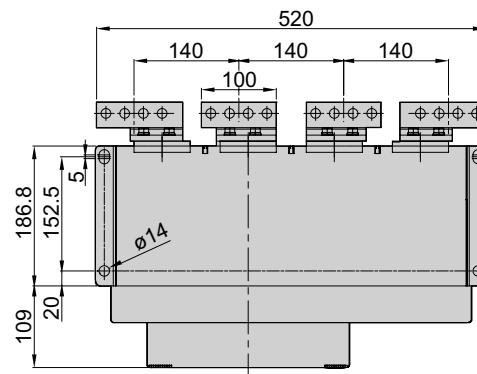
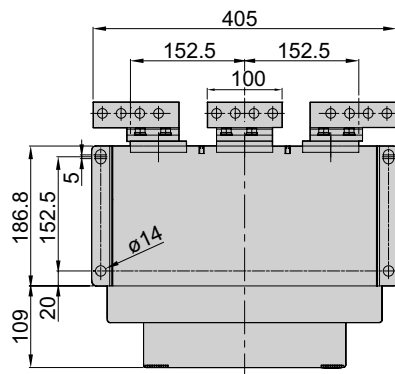

Front view (mm)

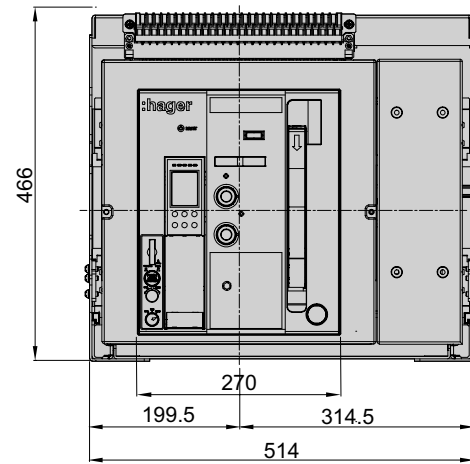
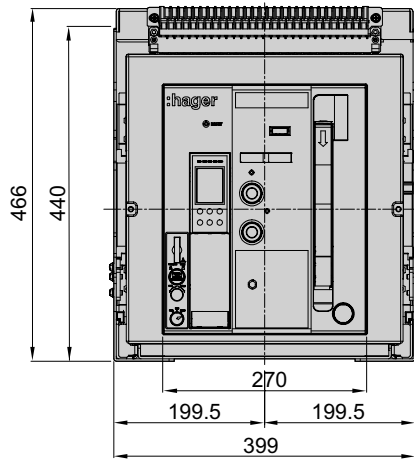

Vertical terminal connection (mm)

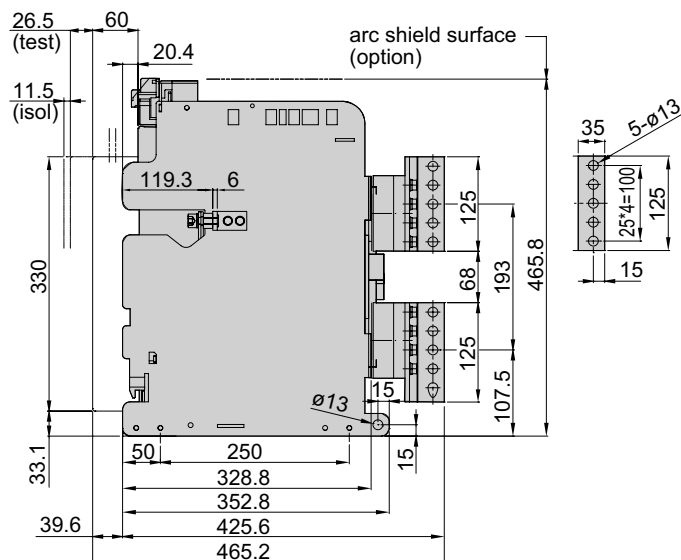
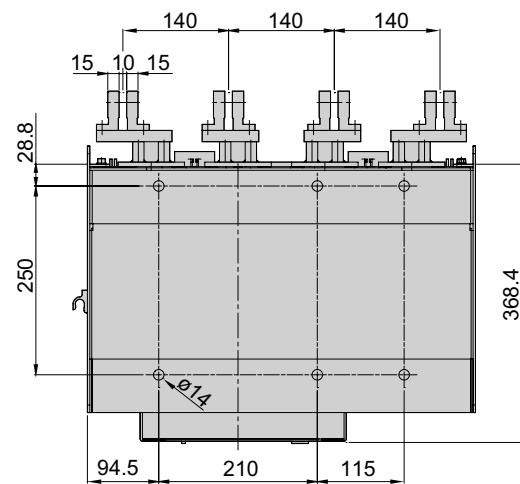
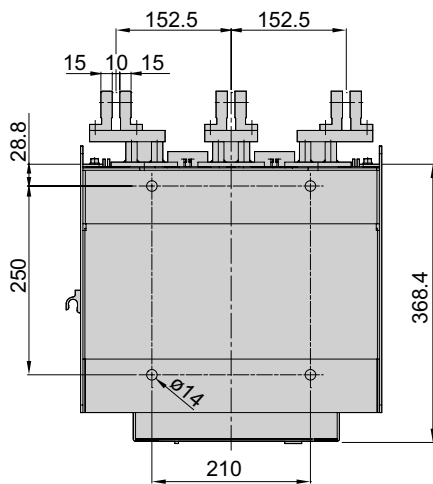

Horizontal terminal connection (mm)

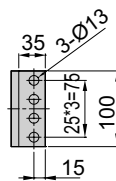
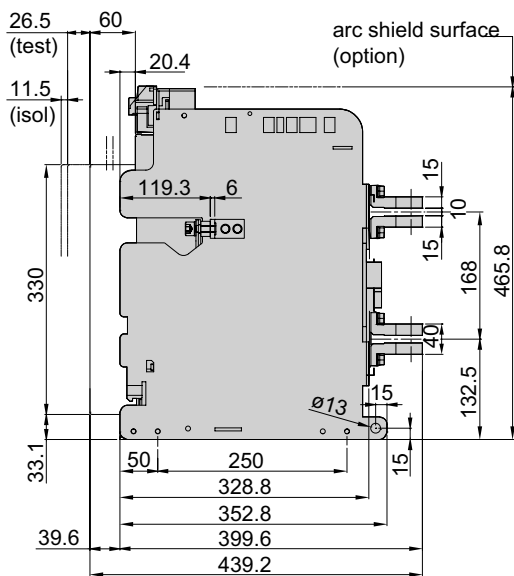
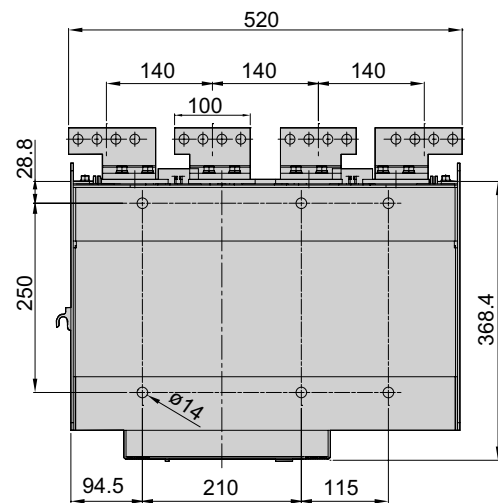
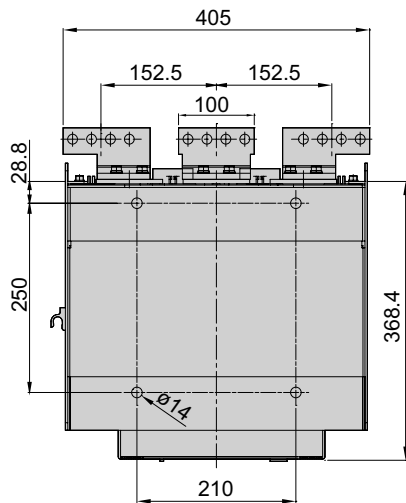

Front view (mm)

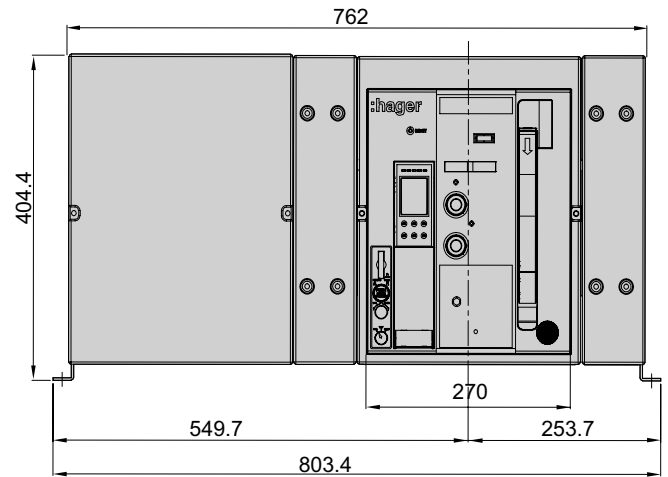
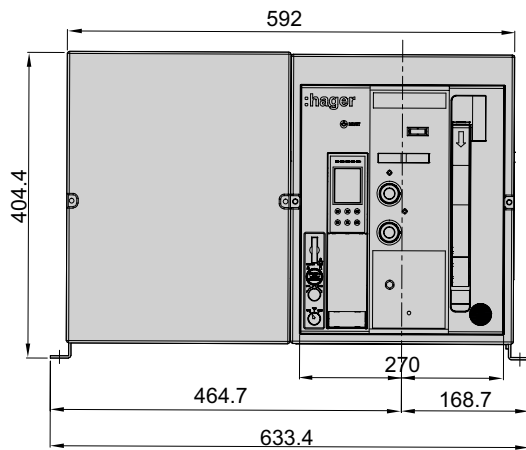

Vertical terminal connection (mm)

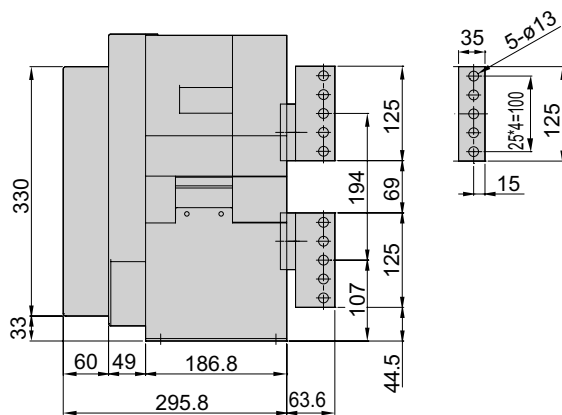
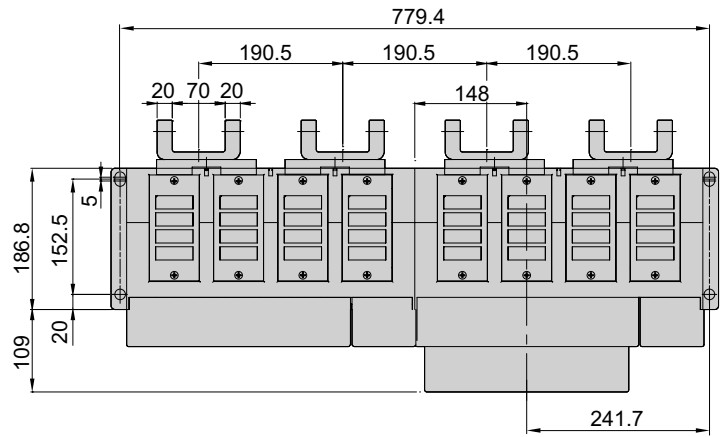
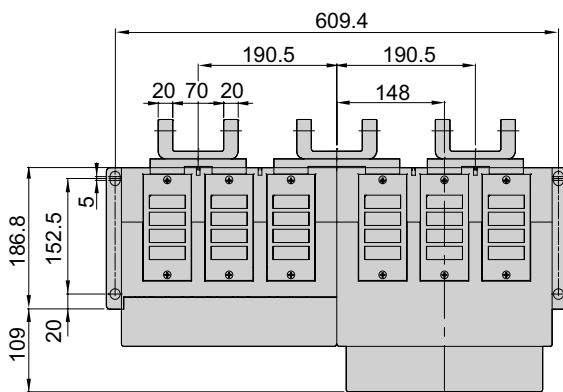

Horizontal terminal connection (mm)

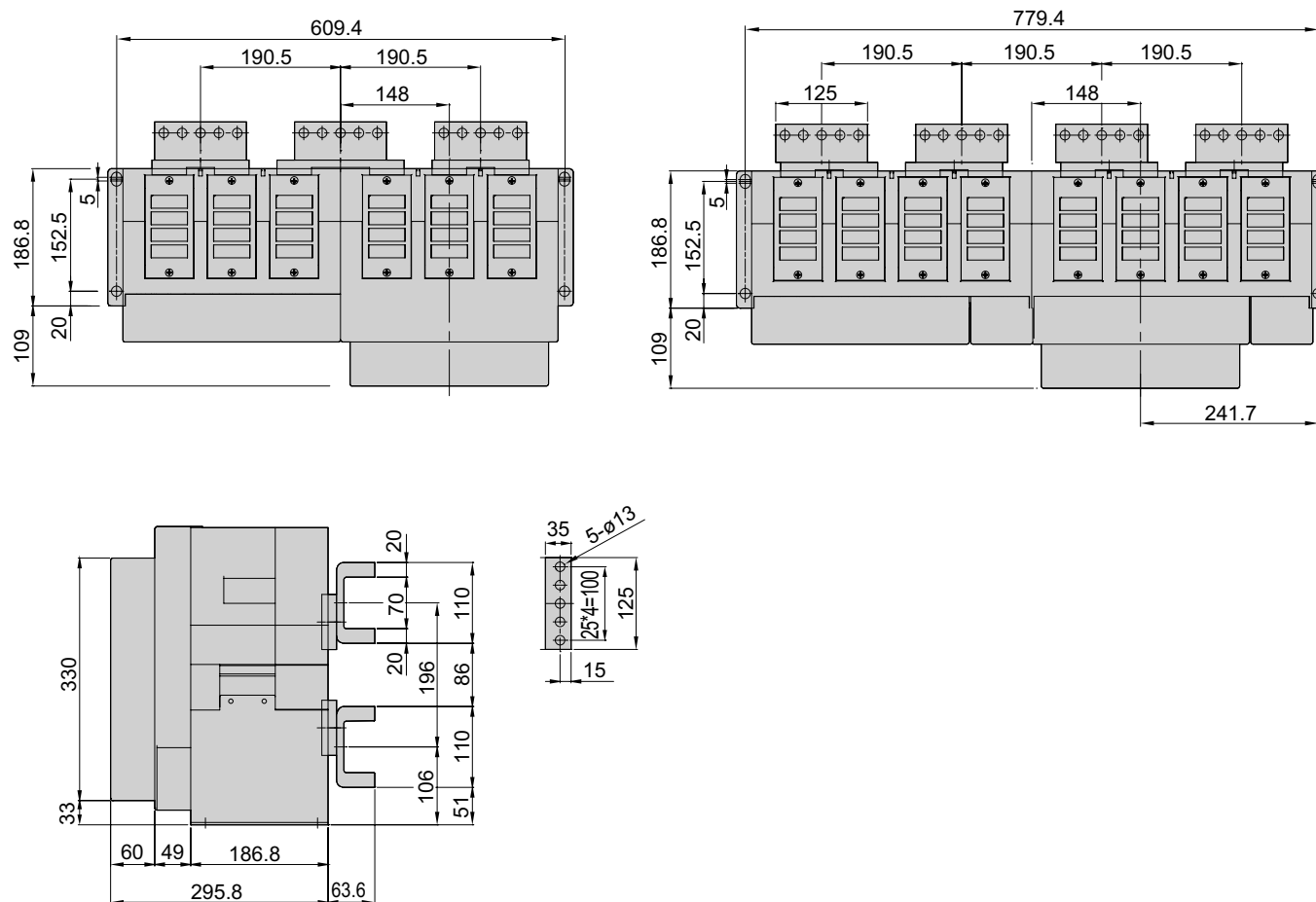

Front view (mm)

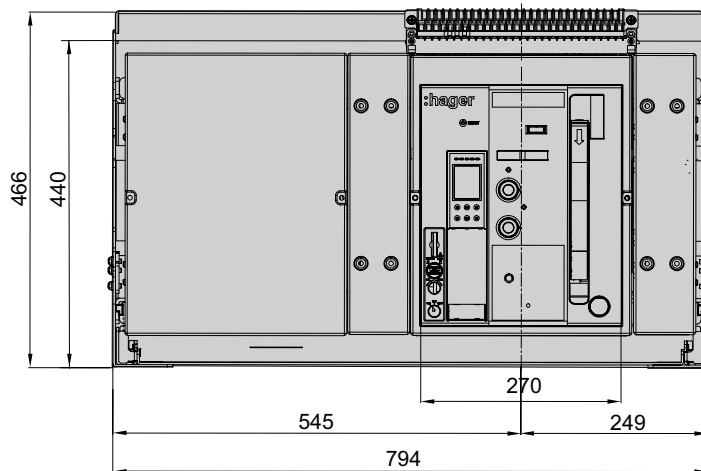
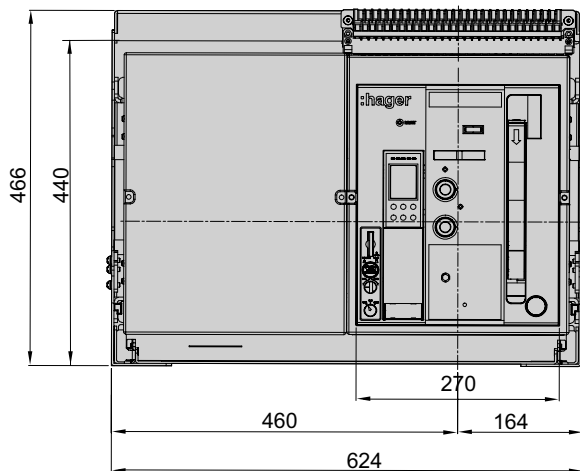

Vertical terminal connection (mm)

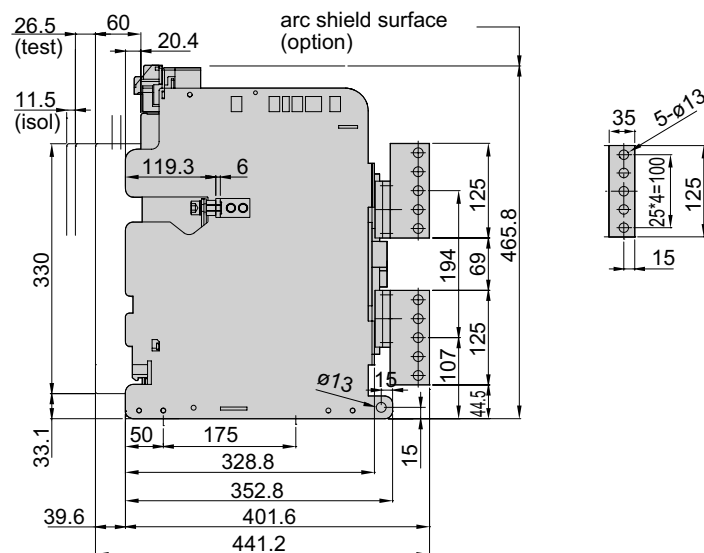
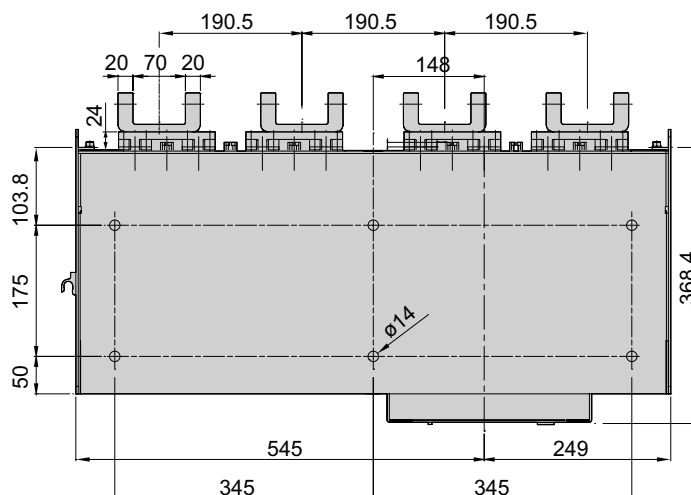
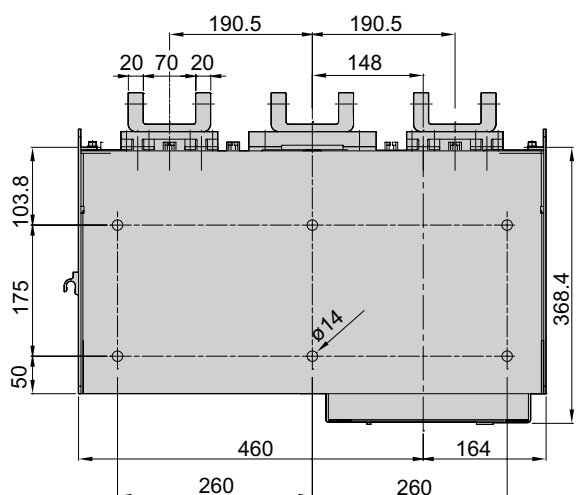

Horizontal terminal connection (mm)

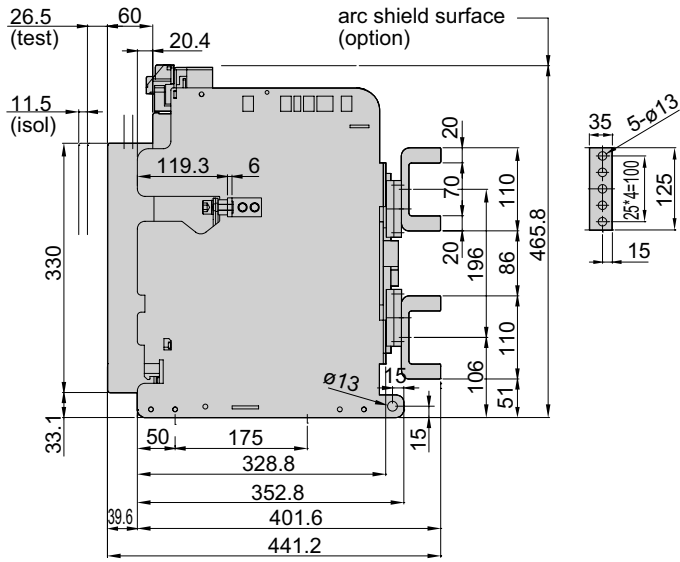
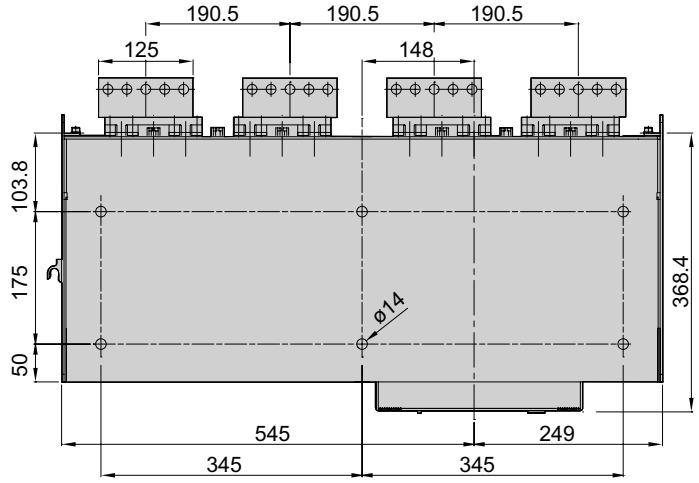
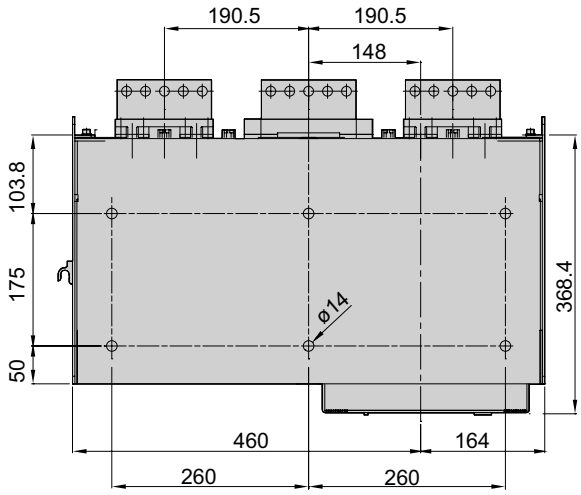

Panel door cut-out for dust cover (mm)

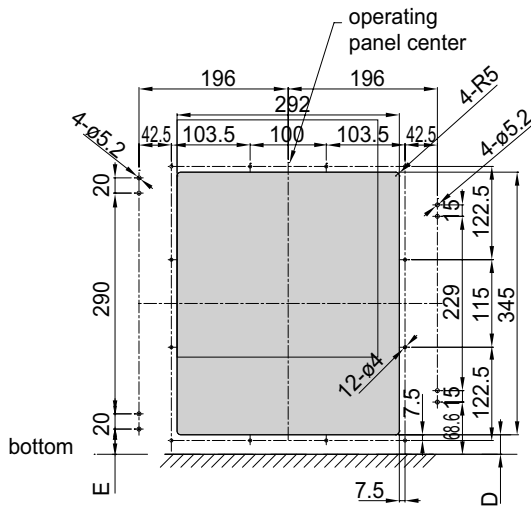

Panel door cut-out for door flange (mm)

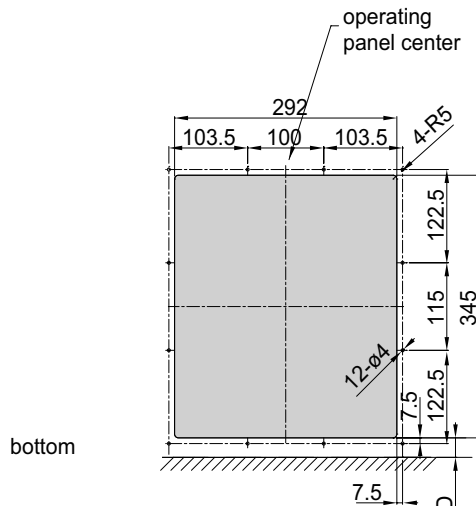

Side view (mm)

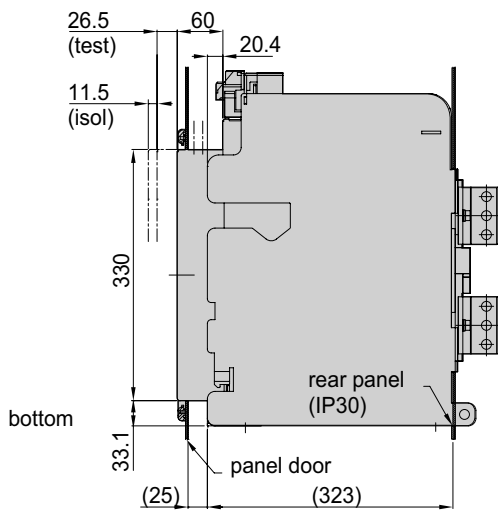

Rear panel cutting size (mm)

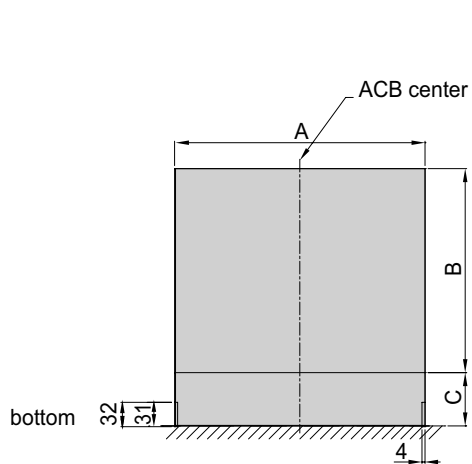

Rear panel cutting size (mm)

Model	A	B	C	D	E
frame A, 3 pole	329	268	70	28.7	36.5
frame A, 4 pole	414	268	70	28.7	36.5
frame B, 3 pole	400	298	55	28.7	36.5
frame B, 4 pole	515	298	55	28.7	36.5
frame C, 3 pole	625	338	35	48.7	56.5
frame C, 4 pole	795	338	35	48.7	56.5

Panel door cut-out for dust cover (mm)

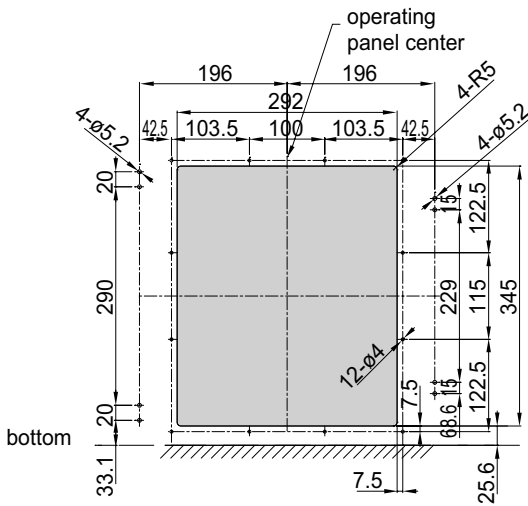

Panel door cut-out for door flange (mm)

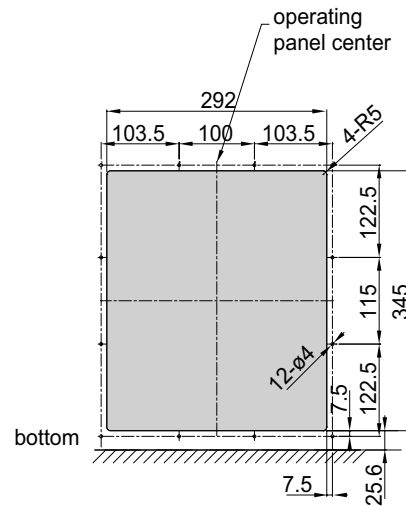

Side view (mm)

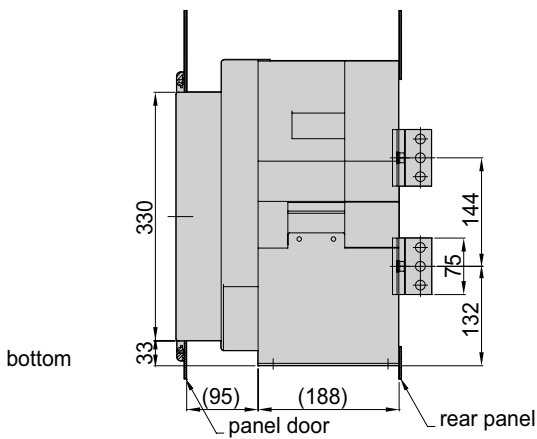

Rear panel cutting size (mm)

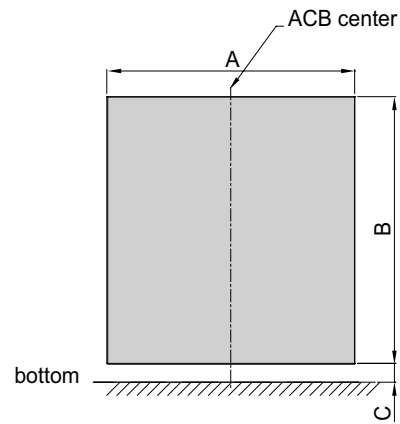

Rear panel cutting size (mm)

Model	A	B	C
frame A, 3 pole	283	355	25
frame A, 4 pole	368	355	25
frame B, 3 pole	354	355	25
frame B, 4 pole	469	355	25
frame C, 3 pole	579	355	25
frame C, 4 pole	749	355	25

Internal resistance and power consumption

Model type	Rated current (A)	Fixed type		Draw-out type	
		Internal resistance (MΩ)	Power consumption (W/3Phase)	Internal resistance (MΩ)	Power consumption (W/3Phase)
frame A	630	15	18	30	36
	800	15	29	30	58
	1,000	15	45	30	90
	1,250	15	70	30	141
	1,600	15	115	30	230
	2,000	13	156	27	324
frame B	2,000	10	120	20	240
	2,500	10	188	20	375
	3,200	10	307	20	614
	4,000	8	384	11	528
frame C	4,000	8	384	11	528
	5,000	8	600	11	825

- 1) Power consumption listed is maximum power consumption for each rated current, 50/60Hz, 3/4 pole.
- 2) This is inner resistance value per pole.
- 3) Power factor = 1.0

Insulation distance

- Insulation distance from arc (in mm)

ACB		A	B
Fixed type		150 (415V) 300 (690V)	60
Draw-out type	without arc shield	150 (415V) 300 (690V)	60
	with arc shield	0	60

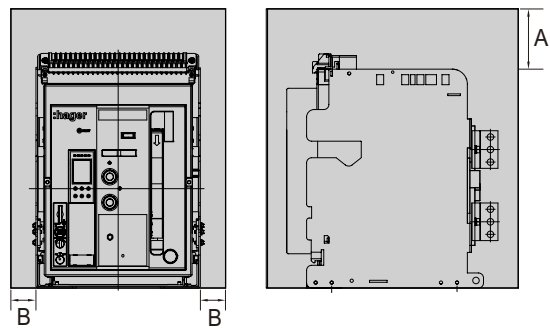

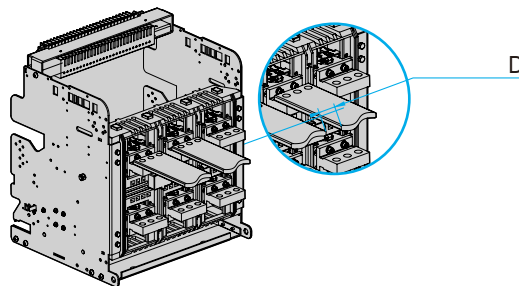

- Minimum insulation distance at charging side (in mm)

Insulating voltage	D
(V) ≤ 600 V	8
600 V < (V) ≤ 1,000 V	14



Rectification of rated current

Frame	Rated current	Terminal connection of ACB body	Applicable busbar size												
				horizontal type					vertical type						
				40°C	45°C	50°C	55°C	60°C	40°C	45°C	50°C	55°C	60°C		
frame A	630A	15t x 50mm x 1EA	5t x 50mm x 2EA	630A	630A	630A	630A	630A	630A	630A	630A	630A	630A	630A	
			10t x 60mm x 1EA												
	800A		6t x 50mm x 2EA	800A	800A	800A	800A	800A	800A	800A	800A	800A	800A	800A	800A
			10t x 60mm x 1EA												
	1,000A		8t x 50mm x 2EA	1,000A	1,000A	1,000A	1,000A	1,000A	1,000A	1,000A	1,000A	1,000A	1,000A	1,000A	1,000A
			6t x 75mm x 2EA	-	-	-	-	-							
	1,250A		8t x 60mm x 2EA	1,250A	1,250A	1,250A	1,250A	1,250A	1,250A	1,250A	1,250A	1,250A	1,250A	1,250A	1,250A
			10t x 50mm x 2EA												
1,600A	6t x 75mm x 3EA	-	-	-	-	-									
	10t x 60mm x 3EA	1,600A	1,600A	1,520A	1,480A	1,420A	1,600A	1,600A	1,600A	1,600A	1,550A	1,550A	1,550A		
frame A	2,000A	20t x 75mm x 1EA	8t x 75mm x 3EA	-	-	-	-	-	2,000A	2,000A	2,000A	1,860A	1,860A		
			10t x 100mm x 2EA												
frame B	630A	20t x 75mm x 1EA	5t x 50mm x 2EA	630A	630A	630A	630A	630A	630A	630A	630A	630A	630A		
			10t x 60mm x 1EA												
	800A		6t x 50mm x 2EA	800A	800A	800A	800A	800A	800A	800A	800A	800A	800A	800A	
			10t x 60mm x 1EA												
	1,000A		8t x 50mm x 2EA	1,000A	1,000A	1,000A	1,000A	1,000A	1,000A	1,000A	1,000A	1,000A	1,000A	1,000A	
			6t x 75mm x 2EA	-	-	-	-	-							
	1,250A		8t x 60mm x 2EA	1,250A	1,250A	1,250A	1,250A	1,250A	1,250A	1,250A	1,250A	1,250A	1,250A	1,250A	
			10t x 50mm x 2EA												
	1,600A		6t x 75mm x 3EA	-	-	-	-	-							
			10t x 60mm x 3EA	1,600A	1,600A	1,600A	1,600A	1,600A	1,600A	1,600A	1,600A	1,600A	1,600A	1,600A	
2,000A	8t x 60mm x 3EA														
	8t x 75mm x 3EA	2,000A	2,000A	2,000A	2,000A	2,000A	2,000A	2,000A	2,000A	2,000A	2,000A	2,000A			
2,500A	10t x 100mm x 2EA	-	-	-	-	-									
	10t x 75mm x 3EA	2,500A	2,500A	2,500A	2,400A	2,300A	2,500A	2,500A	2,500A	2,500A	2,500A	2,500A			
frame B	3,200A	20t x 90mm x 1EA	10t x 100mm x 3EA	-	-	-	-	-	3,200A	3,200A	3,200A	3,050A	3,050A		
			10t x 75mm x 4EA	3,200A	3,200A	3,100A	3,000A	2,900A							
frame B	4,000A horizontal	15t x 100mm x 2EA	10t x 100mm x 4EA	4,000A	4,000A	3,900A	3,800A	3,640A	-	-	-	-	-		
			10t x 125mm x 3EA												
	4,000A vertical		15t x 125mm x 2EA	10t x 100mm x 4EA	-	-	-	-	-	4,000A	4,000A	4,000A	3,800A	3,800A	
frame C	3,200A	20t x 125mm x 2EA	10t x 100mm x 3EA	3,200A	3,200A	3,100A	3,000A	2,900A	3,200A	3,200A	3,200A	3,000A	3,000A		
			10t x 100mm x 4EA	4,000A	4,000A	3,920A	3,860A	3,800A	4,000A	4,000A	4,000A	3,900A	3,900A		
			10t x 125mm x 4EA	5,000A	5,000A	4,900A	4,800A	4,700A	5,000A	5,000A	5,000A	4,900A	4,900A		

t= thickness (mm) EA=number of parts

Altitude

ACB HW is designed for operation at altitudes under 2,000m. At altitudes higher than 2,000m, change the ratings upon service condition.

Altitude	2,000m	3,000m	4,000m	5,000m
withstand voltage (V)	3,500	3,150	2,500	2,100
average insulating voltage (V)	1,000	900	700	600
max. operation voltage (V)	690	590	520	460
rectificated rated current (A)	1×In	0.99×In	0.96×In	0.94×In

Derating table

Switchboard composition connection type											
Model type	Frame A	Frame A									
Rated current ²⁾	630 - 800A	1000A									
Busbar dimensions (mm) ³⁾	2EA x 50 x 6	2EA x 50 x 6									
ventilated switchboard (IP31) ⁴⁾ 	Ta ¹⁾ = 35°C	4					800 ↓				
		3				800 ↓	800 ↓				1,000 ↓
		2			800 ↓	800 ↓	800 ↓			1,000 ↓	1,000 ↓
		1	800 ↓	800 ↓	800 ↓	800 ↓	800 ↓		1,000 ↓	1,000 ↓	1,000 ↓
	Ta = 45°C	4					800 ↓				
		3				800 ↓	800 ↓				1,000 ↓
		2			800 ↓	800 ↓	800 ↓			1,000 ↓	1,000 ↓
		1	800 ↓	800 ↓	800 ↓	800 ↓	800 ↓	1,000 ↓	1,000 ↓	1,000 ↓	1,000 ↓
	Ta = 55°C	4					800 ↓				
		3				800 ↓	800 ↓				1,000 ↓
		2			800 ↓	800 ↓	800 ↓			1,000 ↓	1,000 ↓
		1	800 ↓	800 ↓	800 ↓	800 ↓	800 ↓	1,000 ↓	1,000 ↓	1,000 ↓	1,000 ↓
non-ventilated switchboard (IP52) ⁵⁾ 	Ta = 35°C	4				800 ↓					
		3				800 ↓	800 ↓			1,000 ↓	
		2			800 ↓	800 ↓	800 ↓			1,000 ↓	1,000 ↓
		1	800 ↓	800 ↓	800 ↓	800 ↓	800 ↓	1,000 ↓	1,000 ↓	1,000 ↓	1,000 ↓
	Ta = 45°C	4					800 ↓				
		3				800 ↓	800 ↓				1,000 ↓
		2			800 ↓	800 ↓	800 ↓			1,000 ↓	1,000 ↓
		1	800 ↓	800 ↓	800 ↓	800 ↓	800 ↓	1,000 ↓	1,000 ↓	1,000 ↓	1,000 ↓
	Ta = 55°C	4					800 ↓				
		3				800 ↓	800 ↓				1,000 ↓
		2			800 ↓	800 ↓	800 ↓			1,000 ↓	1,000 ↓
		1	800 ↓	800 ↓	800 ↓	800 ↓	800 ↓	1,000 ↓	1,000 ↓	1,000 ↓	1,000 ↓
Panel dimensions (mm) : W x H x D	800 x 2,300 x 900										
Area of outlet vents (IP31)	350 cm ³										
Area of inlet vents (IP31)	350 cm ³										

- 1) Ta refers to atmospheric temperature outside of panel (IEC 60439-1).
- 2) Rated current observes temperature condition on test according to IEC60947-1,2. When installed inside the panel, derating of additional current and using indicated busbar dimension is required.
- 3) Busbar dimension is manufacturer recommendation. Smaller busbar requires additional derating.
- 4) Ventilation should be designed to drop the temperature of switchboard inside the panel.
- 5) For non-ventilated switchboard, additional forced ventilation should be added to drop the temperature inside the panel.

Derating table

Switchboard composition connection type										
Model type	Frame A				Frame A			Frame A		
Rated current ²⁾	1,250A				1,600A			2,000A		
Busbar dimensions (mm) ³⁾	2EA x 78 x 8				3EA x 75 x 8			2EA x 100 x 10		
ventilated switchboard (IP31) ⁴⁾ 	Ta ¹⁾ = 35°C	4								
		3			1,250 ↓				2,000 ↓	
		2			1,250 ↓	1,250 ↓			1,600 ↓	2,000 ↓
		1	1,250 ↓	1,250 ↓	1,250 ↓	1,250 ↓	1,600 ↓	1,600 ↓	1,600 ↓	
	Ta = 45°C	4								
		3				1,250 ↓				1,900 ↓
		2			1,250 ↓	1,250 ↓			1,600 ↓	2,000 ↓
		1	1,250 ↓	1,250 ↓	1,250 ↓	1,250 ↓	1,600 ↓	1,600 ↓	1,600 ↓	
	Ta = 55°C	4								
		3				1,250 ↓				1,800 ↓
		2			1,250 ↓	1,250 ↓			1,470 ↓	1,900 ↓
		1	1,250 ↓	1,250 ↓	1,250 ↓	1,250 ↓	1,520 ↓	1,600 ↓	1,600 ↓	
non-ventilated switchboard (IP52) ⁵⁾ 	Ta = 35°C	4								
		3				1,250 ↓				1,750 ↓
		2			1,250 ↓	1,250 ↓			1,600 ↓	1,850 ↓
		1	1,250 ↓	1,250 ↓	1,250 ↓	1,250 ↓	1,600 ↓	1,600 ↓	1,600 ↓	
	Ta = 45°C	4								
		3				1,250 ↓				1,750 ↓
		2			1,250 ↓	1,250 ↓			1,500 ↓	1,750 ↓
		1	1,250 ↓	1,250 ↓	1,250 ↓	1,250 ↓	1,500 ↓	1,600 ↓	1,600 ↓	
	Ta = 55°C	4								
		3				1,250 ↓				1,650 ↓
		2			1,250 ↓	1,250 ↓			1,400 ↓	1,650 ↓
		1	1,250 ↓	1,250 ↓	1,250 ↓	1,250 ↓	1,400 ↓	1,520 ↓	1,520 ↓	
Panel dimensions (mm) : W x H x D		800 x 2,300 x 900								
Area of outlet vents (IP31)		350 cm ³								
Area of inlet vents (IP31)		350 cm ³								

Derating table

Switchboard composition connection type													
Model type	Frame B			Frame B			Frame B			Frame B			
Rated current ²⁾	2,000A			2,500A			3,200A			4,000A			
Busbar dimensions (mm) ³⁾	2EA x 100 x 10			3EA x 100 x 10			2EA x 125 x 10			4EA x 125 x 10			
ventilated switchboard (IP31) ⁴⁾ 	Ta ¹⁾ = 35°C	4											
		3			2,000 ↓								
		2	2,000 ↓	2,000 ↓	2,000 ↓	2,375	2,500	3,040	3,200	3,320	3,700		
		1											
	Ta = 45°C	4											
		3			2,000 ↓								
		2	2,000 ↓	2,000 ↓	2,000 ↓	2,250	2,380	2,880	3,100	3,160	3,500		
		1											
	Ta = 55°C	4											
		3			2,000 ↓								
		2	2,000 ↓	2,000 ↓	2,000 ↓	2,100	2,250	2,690	2,900	2,960	3,280		
		1											
non-ventilated switchboard (IP52) ⁵⁾ 	Ta = 35°C	4											
		3			2,000 ↓								
		2	2,000 ↓	2,000 ↓	2,000 ↓	2,125	2,275	2,650	2,850	3,040	3,320		
		1											
	Ta = 45°C	4											
		3			1,900 ↓								
		2	1,960 ↓	1,960 ↓	1,960 ↓	2,000	2,150	2,550	2,700	2,880	3,120		
		1											
	Ta = 55°C	4											
		3			1,780 ↓								
		2	1,800 ↓	1,920 ↓	1,920 ↓	1,900	2,020	2,370	2,530	2,720	2,960		
		1											
Panel dimensions (mm) : W x H x D	800 x 2,300 x 900												
Area of outlet vents (IP31)	350 cm ³												
Area of inlet vents (IP31)	350 cm ³												

- 1) Ta refers to atmospheric temperature outside of panel (IEC 60439-1).
- 2) Rated current observes temperature condition on test according to IEC60947-1,2. When installed inside the panel, derating of additional current and using indicated busbar dimension is required.
- 3) Busbar dimension is manufacturer recommendation. Smaller busbar requires additional derating.
- 4) Ventilation should be designed to drop the temperature of switchboard inside the panel.
- 5) For non-ventilated switchboard, additional forced ventilation should be added to drop the temperature inside the panel.

Derating table

Switchboard composition connection type						
Model type		Frame C	Frame C			
Rated current ²⁾		4,000A	5,000A			
Busbar dimensions (mm) ³⁾		4EA x 125 x 10	5EA x 140 x 10			
ventilated switchboard (IP31) ⁴⁾ 	Ta ¹⁾ = 35°C	4				
		3				
		2	3,900	4,000	4,550	4,850
		1				
	Ta = 45°C	4				
		3				
		2	3,850	3,900	4,350	4,650
		1				
	Ta = 55°C	4				
		3				
		2	3,800	3,850	4,100	4,400
		1				
non-ventilated switchboard (IP52) ⁵⁾ 	Ta = 35°C	4				
		3				
		2	3,800	3,900	4,200	4,500
		1				
	Ta = 45°C	4				
		3				
		2	3,650	3,800	3,950	4,250
		1				
	Ta = 55°C	4				
		3				
		2	3,550	3,650	3,750	4,050
		1				
Panel dimensions (mm) : W x H x D		1,000 x 2,300 x 900				
Area of outlet vents (IP31)		500 cm ³				
Area of inlet vents (IP31)		500 cm ³				

Discrimination table

OCR: LI, LSI, LSIg, LI Amp, LSI Amp, LSIg Amp, LSIg Energy I_R, t_R of the ACB > I_R, t_R of the MCCB / I_{sd}, t_{sd} of the ACB > I_{sd}, t_{sd} of the MCCB / $I_i = 16 \times I_n$, NON, MCR ON																									
Icc (kA)	Upstream	Frame A, type HWAH								Frame A, type HWAN								Frame B, type HWBN							
		max. rated current 2000A $I_{cu} = I_{cs} = 50 \text{kA}$ at 415V								max. rated current 2000A $I_{cu} = I_{cs} = 65 \text{kA}$ at 415V								max. rated current 4000A $I_{cu} = I_{cs} = 65 \text{kA}$ at 415V							
Downstream	(A)	630	800	1000	1250	1600	2000	630	800	1000	1250	1600	2000	630	800	1000	1250	1600	2000						
HDA HHA HNA	x160 TM 18/25/40kA	16	T	T	T	T	T	T	T	T	T	T	T	T	T	T	T	T	T	T	T				
		20	T	T	T	T	T	T	T	T	T	T	T	T	T	T	T	T	T	T	T	T			
		25	T	T	T	T	T	T	T	T	T	T	T	T	T	T	T	T	T	T	T	T			
		32	T	T	T	T	T	T	T	T	T	T	T	T	T	T	T	T	T	T	T	T	T		
		40	T	T	T	T	T	T	T	T	T	T	T	T	T	T	T	T	T	T	T	T	T		
		50	T	T	T	T	T	T	T	T	T	T	T	T	T	T	T	T	T	T	T	T	T		
		63	T	T	T	T	T	T	T	T	T	T	T	T	T	T	T	T	T	T	T	T	T		
		80	T	T	T	T	T	T	T	T	T	T	T	T	T	T	T	T	T	T	T	T	T		
		100	T	T	T	T	T	T	T	T	T	T	T	T	T	T	T	T	T	T	T	T	T		
		125	T	T	T	T	T	T	T	T	T	T	T	T	T	T	T	T	T	T	T	T	T		
160	T	T	T	T	T	T	T	T	T	T	T	T	T	T	T	T	T	T	T	T	T				
HHB HNB	x250 TM 25/40kA	100	T	T	T	T	T	T	T	T	T	T	T	T	T	T	T	T	T	T	T	T			
		125	T	T	T	T	T	T	T	T	T	T	T	T	T	T	T	T	T	T	T	T			
		160	T	T	T	T	T	T	T	T	T	T	T	T	T	T	T	T	T	T	T	T			
		200	T	T	T	T	T	T	T	T	T	T	T	T	T	T	T	T	T	T	T	T	T		
		225	T	T	T	T	T	T	T	T	T	T	T	T	T	T	T	T	T	T	T	T	T		
		250	T	T	T	T	T	T	T	T	T	T	T	T	T	T	T	T	T	T	T	T	T		
HHG HNG HEG	h250 TM 25/50/65kA	20	T	T	T	T	T	T	T	T	T	T	T	T	T	T	T	T	T	T	T	T			
		32	T	T	T	T	T	T	T	T	T	T	T	T	T	T	T	T	T	T	T	T			
		50	T	T	T	T	T	T	T	T	T	T	T	T	T	T	T	T	T	T	T	T			
		63	T	T	T	T	T	T	T	T	T	T	T	T	T	T	T	T	T	T	T	T	T		
		100	T	T	T	T	T	T	T	T	T	T	T	T	T	T	T	T	T	T	T	T	T		
		125	T	T	T	T	T	T	T	T	T	T	T	T	T	T	T	T	T	T	T	T	T		
		160	T	T	T	T	T	T	T	T	T	T	T	T	T	T	T	T	T	T	T	T	T		
		200	T	T	T	T	T	T	T	T	T	T	T	T	T	T	T	T	T	T	T	T	T		
HNH HEH	h250 TM+ 50/70kA	20	T	T	T	T	T	T	T	T	T	T	T	T	T	T	T	T	T	T	T	T			
		32	T	T	T	T	T	T	T	T	T	T	T	T	T	T	T	T	T	T	T	T			
		50	T	T	T	T	T	T	T	T	T	T	T	T	T	T	T	T	T	T	T	T	T		
		63	T	T	T	T	T	T	T	T	T	T	T	T	T	T	T	T	T	T	T	T	T		
		100	T	T	T	T	T	T	T	T	T	T	T	T	T	T	T	T	T	T	T	T	T		
		125	T	T	T	T	T	T	T	T	T	T	T	T	T	T	T	T	T	T	T	T	T		
		160	T	T	T	T	T	T	T	T	T	T	T	T	T	T	T	T	T	T	T	T	T		
		250	T	T	T	T	T	T	T	T	T	T	T	T	T	T	T	T	T	T	T	T	T		
HNC HEC	h250 LSI 50/70kA	40	T	T	T	T	T	T	T	T	T	T	T	T	T	T	T	T	T	T	T	T			
		125	T	T	T	T	T	T	T	T	T	T	T	T	T	T	T	T	T	T	T	T			
		250	T	T	T	T	T	T	T	T	T	T	T	T	T	T	T	T	T	T	T	T			
HHD HND HKD	h400 TM 25/50/70kA	250	T	T	T	T	T	T	T	T	T	T	T	T	T	T	T	T	T	T	T	T			
		300	T	T	T	T	T	T	T	T	T	T	T	T	T	T	T	T	T	T	T	T			
		350	T	T	T	T	T	T	T	T	T	T	T	T	T	T	T	T	T	T	T	T	T		
		400	T	T	T	T	T	T	T	T	T	T	T	T	T	T	T	T	T	T	T	T	T		
HND HED	h630 LSI 50/70kA	250	T	T	T	T	T	T	T	T	T	T	T	T	T	T	T	T	T	T	T	T			
		400	T	T	T	T	T	T	T	T	T	T	T	T	T	T	T	T	T	T	T	T			
		500	T	T	T	T	T	T	T	T	T	T	T	T	T	T	T	T	T	T	T	T	T		
		600	T	T	T	T	T	T	T	T	T	T	T	T	T	T	T	T	T	T	T	T	T		
		630	T	T	T	T	T	T	T	T	T	T	T	T	T	T	T	T	T	T	T	T	T		
HNK HEK	h800 TM 50/70kA	630	T	T	T	T	T	T	T	T	T	T	T	T	T	T	T	T	T	T	T	T			
		800	T	T	T	T	T	T	T	T	T	T	T	T	T	T	T	T	T	T	T	T	T		
HNE HEE	h1000 LSI 50/70kA	630	T	T	T	T	T	T	T	T	T	T	T	T	T	T	T	T	T	T	T	T			
		700	T	T	T	T	T	T	T	T	T	T	T	T	T	T	T	T	T	T	T	T	T		
		800	T	T	T	T	T	T	T	T	T	T	T	T	T	T	T	T	T	T	T	T	T		
HNF HEF	h1600 LSI 50/70kA	1000	T	T	T	T	T	T	T	T	T	T	T	T	T	T	T	T	T	T	T	T			
		800	T	T	T	T	T	T	T	T	T	T	T	T	T	T	T	T	T	T	T	T	T		
		1250	T	T	T	T	T	T	T	T	T	T	T	T	T	T	T	T	T	T	T	T	T		
		1600	T	T	T	T	T	T	T	T	T	T	T	T	T	T	T	T	T	T	T	T			

			Upstream								
			Frame A, type HWAH			Frame A, type HWAN					
			630-800A	1000-1250A	1600-2000A	630-800A	1000-1250A	1600-2000A	630-800A		
			IEC 60947-2	50kA			65kA				
Downstream	x160 TM	HDA	18kA	18	18	18	18	18	18		
		HHA	25kA	25	25	25	25	25	25		
		HNA	40kA	40	40	40	40	40	40		
	x250 TM	HHB	25kA	25	25	25	25	25	25	25	
		HNB	40kA	40	40	40	40	40	40	40	
	h250 TM	HHG	25kA	25	25	25	25	25	25	25	
		HNG	50kA	50	50	50	50	50	50	50	
		HEG	65kA	50	50	65	65	65	65	65	
	h250 TM+	HNH	50kA	50	50	50	50	50	50	50	
		HEH	70kA	50	50	50	65	65	65	65	
	h250 LSI	HNC	50kA	50	50	50	50	50	50	50	
		HEC	70kA	50	50	50	65	65	65	65	
	h400 TM	HHD	25kA	25	25	25	25	25	25	25	
		HND	50kA	50	50	50	50	50	50	50	
		HKD	70kA	50	50	50	65	65	65	65	
	h630 LSI	HND	50kA	50	50	50	50	50	50	50	
		HED	70kA	50	50	50	65	65	65	65	
	h800 TM	HNK	50kA	50	50	50	50	50	50	50	
		HEK	70kA	50	50	50	65	65	65	65	
	h1000 LSI	HNE	50kA		50	50			50	50	
HEE		70kA		50	50			65	65		
h1600 LSI	HNF	50kA			50				50		
	HEF	70kA			50				65		

Max. cascading value in kA rms according to IEC 60947-2.
 Network: 3 phases + neutral 220/380 ~ 240/415 VAC.

	Frame B, type HWBN			Frame B, type HWBS			Frame B, type HWBP			Frame C, type HWCP
	630-800A	1000-1250A	1600-4000A	630-800A	1000-1250A	1600-4000A	630-800A	1000-1250A	1600-4000A	3200-5000A
	65kA			85kA			100kA			100kA
	18	18	18	18	18	18	18	18	18	18
	25	25	25	25	25	25	25	25	25	25
	40	40	40	40	40	40	40	40	40	40
	25	25	25	25	25	25	25	25	25	25
	40	40	40	40	40	40	40	40	40	40
	25	25	25	25	25	25	25	25	25	25
	50	50	50	50	50	50	50	50	50	50
	65	65	65	65	65	65	65	65	65	65
	50	50	50	50	50	50	50	50	50	50
	65	65	65	70	70	70	70	70	70	70
	50	50	50	50	50	50	50	50	50	50
	65	65	65	70	70	70	70	70	70	70
	25	25	25	25	25	25	25	25	25	25
	50	50	50	50	50	50	50	50	50	50
	65	65	65	70	70	70	70	70	70	70
	50	50	50	50	50	50	50	50	50	50
	65	65	65	70	70	70	70	70	70	70
		50	50		50	50		50	50	50
		65	65		70	70		70	70	70
			50			50			50	50
			65			70			70	70

Ambient temperature

- Operating condition: -5°C to 50°C is recommended.
- Chassis is fixed to a switchboard.
- The average temperature for 24 hours should be within 35°C.
- Reduce the continuous conducting current when the temperature is over 50°C (45°C for horizontal type connection).

Load (I/In)

Load	Using	Effect	Installation
$I/I_n \leq 80\%$	24/24 hours	-	normal condition (recommended)
$80 < I/I_n \leq 80\%$	24/24 hours	-	periodic inspection
$I/I_n = 100\%$	24/24 hours	plastic insulator color changed	exhaust added

Atmospheric conditions

- Do not apply under corrosive or ammonia gas circumstances (H₂S, SO₂, NH₃).
- Use in clean air condition.

Altitude

Item	Altitude		
	2000 m	2600 m	3900 m
Isolating voltage (V)	1,000	950	800
Operating voltage (V)	690	655.5	552
Allowed current (V)	$1 \times I_n$	$0.99 \times I_n$	$0.96 \times I_n$

Relative humidity

- Relative humidity should be under 85%.

Storage conditions

- Device without its control unit: -25°C to 85°C
- Device with control unit: -15°C to 70°C
- The product with charging motor should be stored in open position.

Horizontal type (mm)

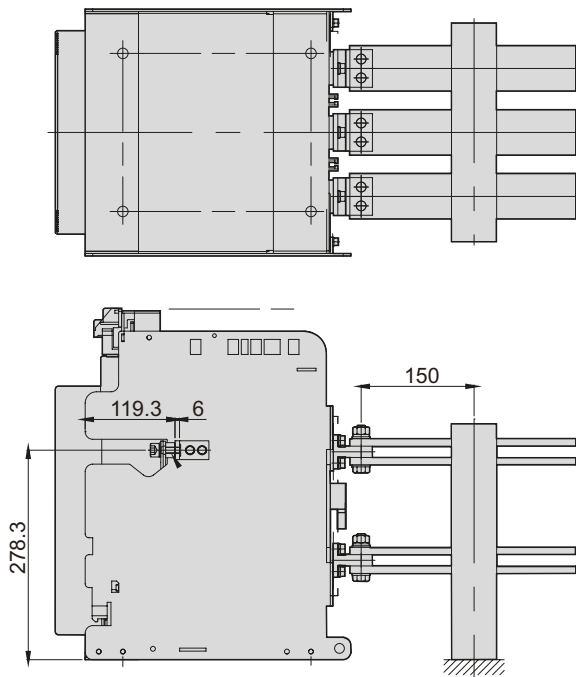

Vertical type (mm)

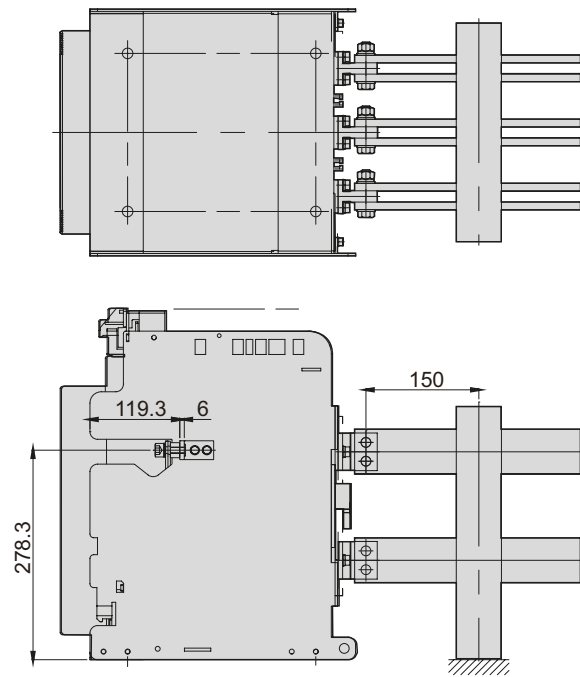

Front type (mm)

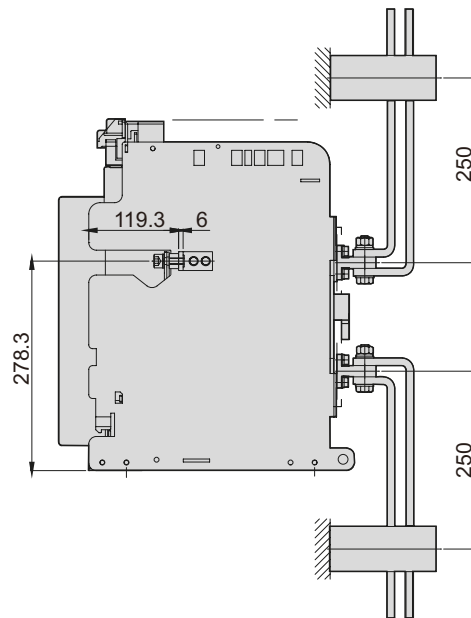
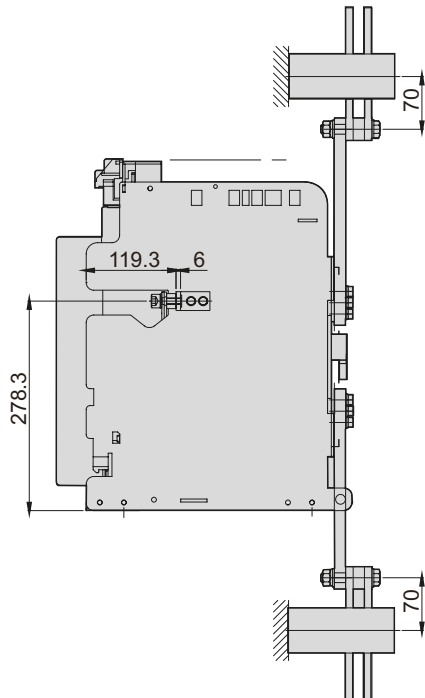

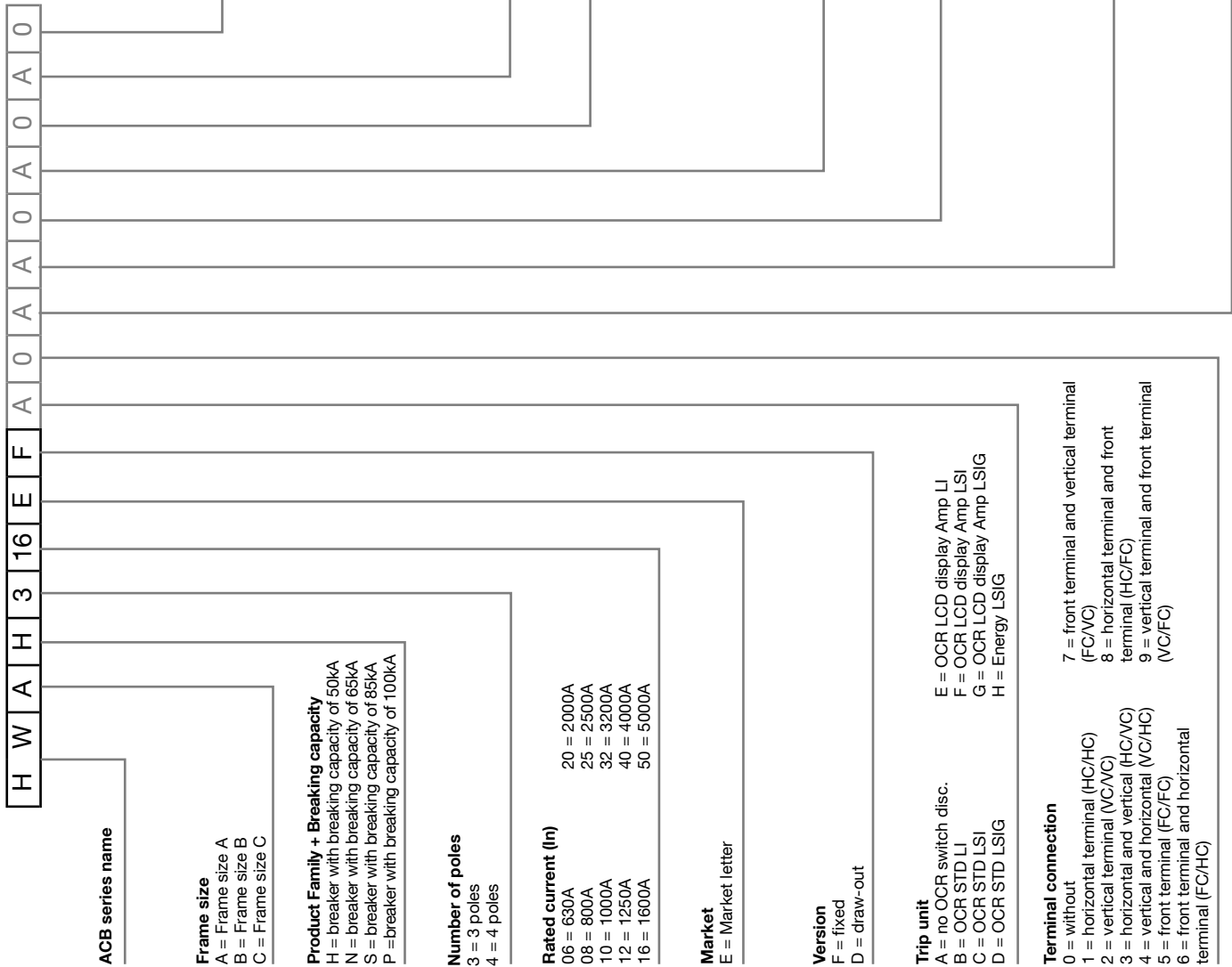

Position switch & mechanical interlock
 0 = without
 1 = isolated 1C, test 1C, connected 2C
 2 = inserted 1C, isolated 1C, test 1C, connected 1C
 3 = inserted 1C, isolated 1C, test 3C, connected 3C
 4 = inserted 2C, isolated 2C, test 2C, connected 2C
 5 = without & MI
 6 = isolated 1C, test 1C, connected 2C & MI
 7 = inserted 1C, isolated 1C, test 1C, connected 1C & MI
 8 = inserted 1C, isolated 1C, test 3C, connected 3C & MI
 9 = inserted 2C, isolated 2C, test 2C, connected 2C & MI

OFF lock (key lock device) & arc shield
 A = without
 B = cylinder type 1
 C = cylinder type 2
 D = cylinder type 3
 E = cylinder type 4
 F = cylinder type 5
 G = cylinder type 1 & arc shield
 H = cylinder type 2 & arc shield
 I = cylinder type 3 & arc shield
 J = cylinder type 4 & arc shield
 K = cylinder type 5 & arc shield
 L = arc shield only
 M = Ronis type 1
 N = Ronis type 2
 O = Ronis type 3
 P = Ronis type 1 & arc shield
 Q = Ronis type 2 & arc shield
 R = Ronis type 3 & arc shield
 S = Castell type 1
 T = Castell type 2
 U = Castell type 3
 V = Castell type 1 & arc shield
 W = Castell type 2 & arc shield
 X = Castell type 3 & arc shield

Auxiliary switch & counter
 0 = with auxiliary switch std 4a+5b without counter
 1 = with auxiliary switch std 4a+5b with counter

Under voltage release or 2nd SH coil
 A = without
 B = AC/DC 110V
 C = AC/DC 220V
 D = AC 380V
 E = AC 440V
 F = DC 24V
 G = DC 48V
 H = AC/DC 110V with time delay
 I = AC/DC 220V with time delay
 J = AC 380V with time delay
 K = AC 440V with time delay
 L = DC 24V with time delay
 M = DC 48V with time delay
 N = AC/DC 110V double shunt release
 O = AC/DC 220V double shunt release
 P = AC 380V double shunt release
 Q = AC 440V double shunt release
 R = DC 24V double shunt release
 S = DC 48V double shunt release

Closing release
 0 = without
 1 = AC/DC 110V
 2 = AC/DC 220V
 3 = AC 380V
 4 = AC 440V
 5 = DC 24V
 6 = DC 48V

Motor operator & ready to close switch
 A = without
 B = AC/DC 110V motor only
 C = AC/DC 220V motor only
 D = AC 380V motor only
 E = AC 440V motor only
 F = DC 24V motor only
 G = DC 48V motor only
 N = AC/DC 110V motor with RTC
 O = AC/DC 220V motor with RTC
 P = AC 380V motor with RTC
 Q = AC 440V motor with RTC
 R = DC 24V motor with RTC
 S = DC 48V motor with RTC

Shunt release
 A = without
 B = AC/DC 110V
 C = AC/DC 220V
 D = AC380V
 E = AC 440V
 F = DC 24V
 G = DC 48V

Hager Electro S.A.S.
132 Boulevard d'Europe
B.P.3
67215 Obernai Cedex
France

Phone : +33 (0)3 88 49 50 50
Fax : +33 (0)3 88 49 51 44
www.near-east.hager.com
www.africa.hager.com

Hager Electro Ltd
Unit 815, 8/F,
681 Cheung Sha Wan Road,
Kowloon, Hong Kong

Phone: +(852) 2688 0228
Fax: +(852) 2688 0336
e-mail: sales@hager.hk
www.hager.hk

Hager Electro Ltd, VN Rep. office
3rd Floor, CNC Building,
8-10 Nguyen Ba Tuyen, Ward 12,
Tan Binh Dist., Hochiminh City,
Vietnam

Phone: +(84) 8 3811 3549/50/51
Fax: +(84) 8 3811 3552
e-mail: sales@hager.com.vn
www.hager.hk

Hager Electro Systems Pte Ltd
21 Serangoon North Ave 5,
#06-03 Ban Teck Han Building
Singapore 554864

Phone: +(65) 6383 1030
Fax: +(65) 6383 0230
e-mail: sales@hager.sg
www.hager.sg

Hager Engineering (M) Sdn. Bhd
Level 5, Lot 8, Jalan Astaka U8/84
Bukit Jelutong, 40150 Shah Alam
Selangor, Malaysia

Phone: +(603) 7859 1935
Fax: +(603) 7859 1945
e-mail: general@hager.my
www.hager.my

